

# 目 次

<p>鉄筋コンクリートU形 JIS A 5372..... 2</p> <p>鉄筋コンクリートU形ふた..... 2</p> <p>ソケット付鉄筋コンクリートU形..... 3</p> <p>U形分水口..... 3</p> <p>車道用U字溝 (林道用)..... 4</p> <p>鉄筋コンクリート片肉厚U形..... 4</p> <p>鉄筋コンクリートL形 JIS A 5372..... 5</p> <p>鉄筋コンクリートL形切下..... 5</p> <p>L形用集水柵 (東京都型)..... 6</p> <p>L形縁塊..... 6</p> <p>歩車道境界ブロック JIS A 5371..... 7</p> <p>歩車道境界ブロック曲..... 7</p> <p>歩車道境界ブロック切下..... 8</p> <p>歩車道境界ブロック切下 (身障者用)..... 8</p> <p>歩車道境界ブロック端末..... 9</p> <p>街渠柵..... 9</p> <p>両面歩車道境界ブロック..... 10</p> <p>両面歩車道境界ブロック切下..... 11</p> <p>両面A身障者用切下ブロック..... 11</p> <p>ベース付歩車道境界ブロック A型..... 12</p> <p>ベース付歩車道境界ブロック C型..... 13</p> <p>L型街渠 A-15 (両面)..... 14, 15</p> <p>L型街渠 A-15 (片面)..... 16, 17</p> <p>エプロン付歩車道境界ブロック C-15..... 18, 19</p> <p>エプロン付歩車道境界ブロック C-15 (底版張出型)..... 20, 21</p> <p>中央分離帯ブロック..... 22</p> <p>L型街渠用ブロック..... 23</p> <p>並木柵用コンクリートブロック..... 24</p> <p>車止めブロック..... 24</p> <p>コンクリート平板..... 25</p> <p>コンクリート特殊境界ブロック..... 25</p> <p>V型溝..... 25</p> <p>水止めブロック・止水駒..... 26</p> <p>道路用側溝 GPU 2 (歩道用)..... 27</p> <p style="padding-left: 20px;">GPU 3 (T-25)</p> <p>道路用側溝深溝型 GPU 2 歩道用..... 28</p> <p style="padding-left: 20px;">GPU 3 車道用</p> <p>道路用側溝土留型 GPU D 2 歩道用..... 29</p> <p style="padding-left: 20px;">GPU D 3 車道用</p> <p>道路用鉄筋コンクリート側溝蓋 PC 3 歩道用..... 30</p> <p style="padding-left: 20px;">PC 4 T-25</p> <p>ハイブリッド側溝 HB-PU..... 31</p> <p>ハイブリッド側溝 MHB-PU..... 32</p> <p>ハイブリッド側溝 HB-PU (303土留壁付)..... 33</p> <p>ハイブリッド側溝 HB-FS..... 34~36</p> <p>ハイブリッド側溝用蓋 (HB-FS用)..... 37</p> <p>ハイブリッド側溝 HB-FSG (横断用)..... 38~40</p> <p>ハイブリッド側溝 HB-FS (調整用)..... 41</p> <p>ハイブリッド側溝 HB-FSフレキシブル..... 42</p> <p>ハイブリッド側溝 HB-FSフレキシブル端部..... 43</p> <p>ハイブリッド側溝 HB-FS (土留め)..... 44</p> <p>ハイブリッド側溝 HB-BOX..... 45</p> <p>ハイブリッド側溝 HB-BOX (集水部)..... 46</p> <p>ハイブリッド側溝 HB-BOX (集水柵)..... 47</p> <p>横断用グレーチング側溝GLU T-25..... 48</p> <p>横断用グレーチング側溝深溝型GLU T-25..... 49</p> <p>トライボット横断側溝 TLU T-25..... 50</p>	<p>土留め付側溝 BLU..... 51</p> <p>長尺U形側溝 LU 2 T-14..... 52</p> <p style="padding-left: 20px;">LU 3 T-25</p> <p>長尺U形側溝 LU 3 T-25..... 53</p> <p>ロング用受台..... 53</p> <p>落蓋式U形側溝 (A型)..... 54</p> <p>落蓋式U形側溝蓋..... 54</p> <p>道路用鉄筋コンクリート側溝 1種歩道用 3種T-25..... 55</p> <p>道路用鉄筋コンクリート側溝ふた 1種歩道用 3種T-25..... 55</p> <p>溝蓋 現場打ち用 (群馬県土木部標準型)..... 56</p> <p>集水柵蓋 (国土交通省型)..... 57</p> <p>長尺側溝F型 (12×12) 歩道用..... 58</p> <p>長尺側溝H型 (12×12) 歩車道用..... 58</p> <p>長尺側溝 (12×15) 車道用..... 59</p> <p>長尺側溝D型 (15×15) 横断用..... 59</p> <p>長尺側溝NF型 (12×12) 歩道用..... 60</p> <p>長尺側溝NH型 (12×12) 車道用..... 60</p> <p>長尺側溝N型 (12×15) 車道用..... 61</p> <p>ロング用受台..... 61</p> <p>ロング用集水柵..... 62</p> <p>土留め付側溝 FC..... 63</p> <p>埼玉県型溝蓋 (車道用・歩道用)..... 64</p> <p>自由勾配側溝 FSD..... 65</p> <p>FSD側溝用蓋 PCD 3 PCD 4..... 66</p> <p>自由勾配側溝横断 FSD-G..... 67</p> <p>自由勾配側溝土留め FSDD..... 68</p> <p>自由勾配側溝 FSD (1m、短尺、斜切)..... 69</p> <p>自由勾配側溝 FSD (自在コーナー)..... 70</p> <p>L型擁壁 SL..... 71, 72</p> <p>L型擁壁天端勾配 SL-S..... 73</p> <p>L型擁壁 (新基準H26適用)..... 74</p> <p>L型擁壁 TSL..... 75</p> <p>L型擁壁 (フェンス付) TSL-F..... 76</p> <p>逆L型擁壁 SLR..... 77, 78</p> <p>ボックスカルバート T-25..... 79</p> <p>ボックスカルバート (協会型) T-25..... 80</p> <p>鉄筋コンクリート床版..... 81</p> <p>組立土留 くい 柵板..... 82</p> <p>排水溝 RDU..... 83</p> <p>U形水路 RU..... 84</p> <p>水路排水路兼用型・U形水路用蓋..... 85</p> <p>ベンチフリュームI形..... 86</p> <p>ベンチフリュームII形..... 87</p> <p>ベンチフリューム用蓋 T-4..... 88</p> <p>ベンチボックス T-14..... 89</p> <p>遠心力鉄筋コンクリート管B形管..... 90</p> <p>遠心力鉄筋コンクリート管C形管..... 90</p> <p>鉄筋コンクリート人孔側塊..... 91</p> <p>人孔床版塊..... 92</p> <p>鉄筋コンクリート汚水柵・排水柵 (CD型)..... 93</p> <p>鉄筋コンクリート組立塀..... 94</p> <p>溜柵 改良柵..... 95</p> <p>井戸側..... 96</p> <p>表示杭..... 97</p> <p>集水柵..... 98, 99</p>
---	---

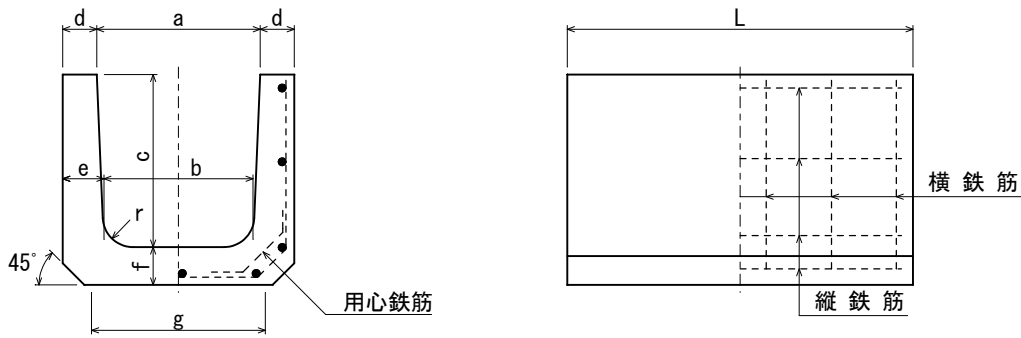

呼び名	寸法 (mm)									縦鉄筋		横鉄筋		参考重量 (kg)	
	a	b	c	d	e	f	g	r	L	径	数(本)	径	数(本)	L=600	L=2000
150	150	140	150	30	35	35	160	30	600	2.6	5	2.6	5	24	—
180	180	170	180	35	40	40	190	50	600	2.6	5	3.2	5	34	—
240	240	220	240	45	50	50	240	50	600	3.2	7	3.2	5	55	184
300A	300	260	240	50	60	60	300	50	600	3.2	9	4.0	5	70	—
300B	300	260	300	50	60	60	300	50	600	3.2	9	4.0	5	79	264
300C	300	260	360	50	60	65	300	50	600	3.2	11	4.0	7	92	—
360A	360	310	300	50	65	65	360	50	600	4.0	11	4.0	6	90	—
360B	360	310	360	50	65	65	360	50	600	4.0	11	4.0	8	100	333
450	450	400	450	55	70	70	430	70	600	4.0	13	5.0	8	134	447
600	600	540	600	70	80	80	600	70	600	6.0	15	6.0	8	209	697

\*L = 2000mmのものは1000mmも用意できます。

## 鉄筋コンクリートU形ふた

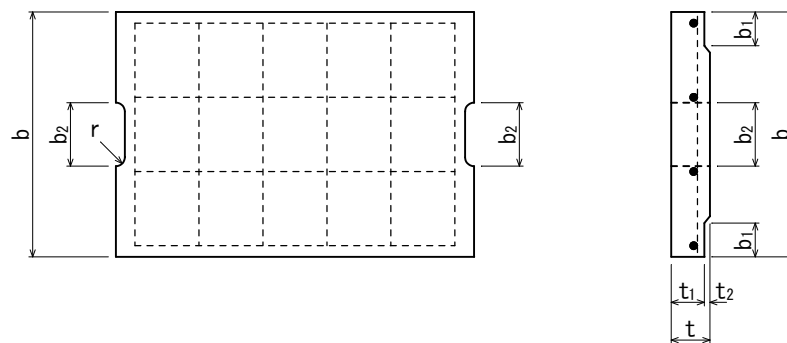

種別	呼び名	寸法 (mm)									縦鉄筋		横鉄筋		参考重量 (kg)
		b	b <sub>1</sub>	t	t <sub>1</sub>	t <sub>2</sub>	L	r	b <sub>2</sub>	径	本	径	本		
1種	150	210	35	35	30	5	600	15	75	2.6	3	2.6	5	10	
	180	250	40	40	35	5	600	15	75	2.6	3	2.6	6	14	
	240	330	50	45	40	5	600	15	90	3.2	4	3.2	6	21	
	300	400	55	60	50	10	600	15	100	3.2	4	4.0	6	32	
	360	460	55	65	55	10	600	18	120	3.2	4	5.0	6	41	
	450	560	60	70	60	10	600	18	120	4.0	5	6.0	5	54	
2種	600	740	75	75	65	10	600	18	150	4.0	6	6.0	6	77	
	150	210	35	90	80	10	600	15	75	6.0	3	6.0	7	26	
	180	250	40	90	80	10	600	15	75	6.0	4	D10	5	31	
	240	330	50	100	85	15	600	15	90	6.0	5	D10	5	44	
	300	400	55	100	85	15	600	15	100	6.0	6	D10	6	54	
	360	460	55	100	85	15	600	18	120	6.0	7	D10	7	63	
種	450	560	60	120	100	20	600	18	120	D10	6	D10	7	92	
	600	740	75	150	130	20	600	18	150	D10	6	D13	6	153	

\*径線6.0の代わりにD6を使用してもよい。

# ソケット付鉄筋コンクリートU形

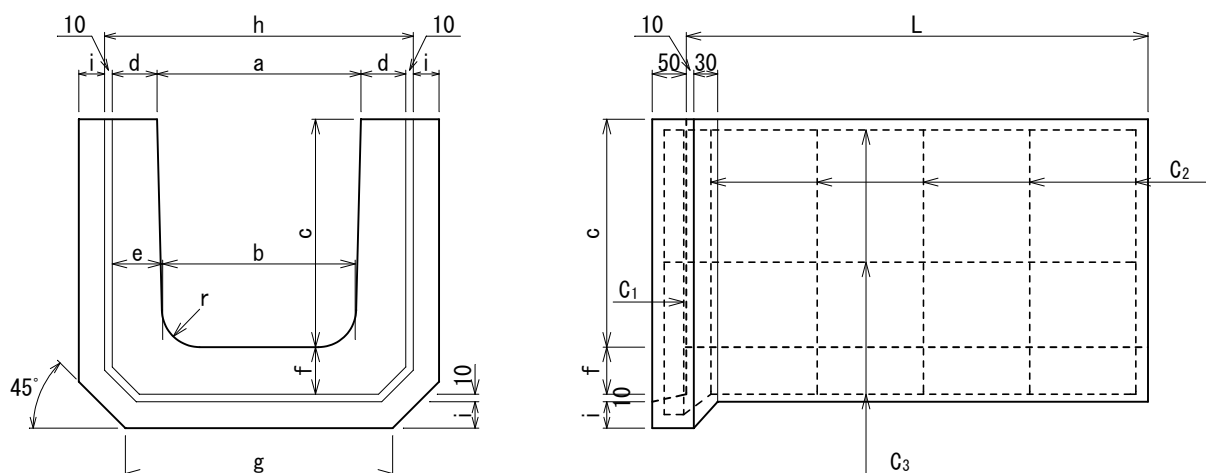

呼び名	寸 法 (mm)										鉄 筋						参考重量 (kg)
											C <sub>1</sub>		C <sub>2</sub>		C <sub>3</sub>		
	a	b	c	d	e	f	g	h	i	L	径	本	径	本	径	本	
240	240	220	240	45	50	50	260	350	25	600	3.2	2	3.2	5	3.2	7	63
300	300	260	300	50	60	60	320	420	30	600	4.0	2	4.0	5	3.2	9	91
360	360	310	360	50	65	65	380	480	35	600	4.0	2	4.0	8	4.0	11	115
450	450	400	450	55	70	70	450	580	40	600	4.0	2	4.0	8	5.0	13	155

# U形分水口

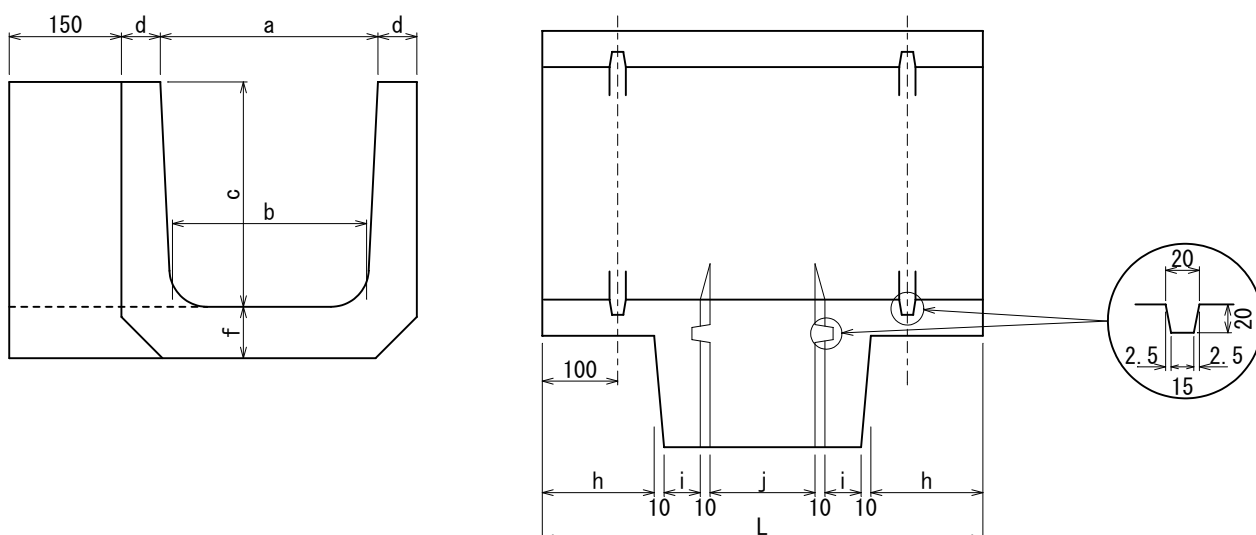

呼び名	寸 法 (mm)										縦鉄筋		横鉄筋		補助筋		参考重量 (kg)
	a	b	c	d	f	h	i	j	L	径	本	径	本	径	本		
240	240	220	240	45	50	160	45	150	600	3.2	7	3.2	5	3.2	2	67	
300	300	260	300	50	60	155	50	150	600	3.2	9	4.0	5	4.0	2	94	
360	360	310	300	50	65	140	50	180	600	4.0	11	4.0	8	4.0	3	116	
450	450	400	450	55	70	135	55	180	600	4.0	13	5.0	8	5.0	3	156	
600	600	540	600	70	80	120	70	180	600	6.0	15	6.0	8	6.0	3	242	

# 車道用U字溝 (林道用)

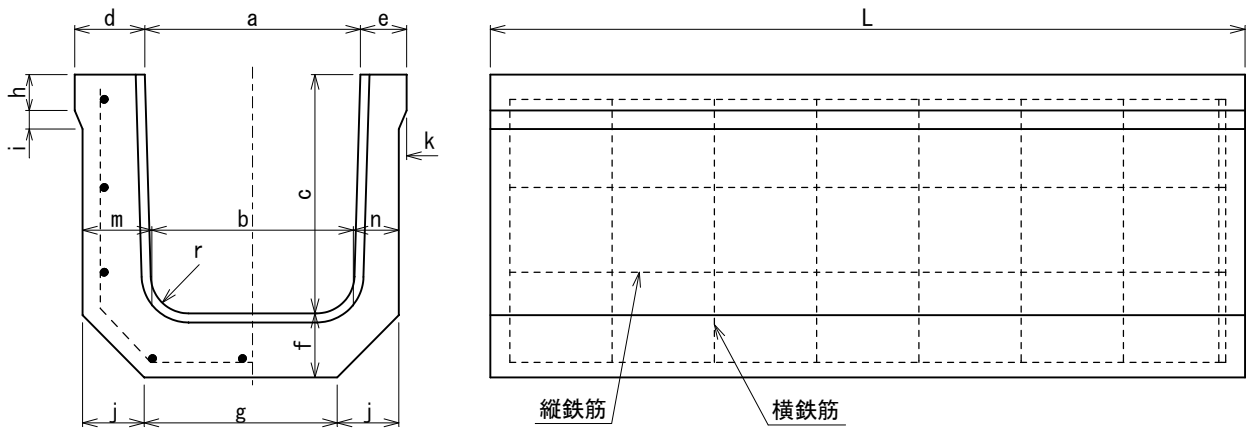

呼び名	寸法 (mm)															縦鉄筋		横鉄筋		参考重量 (kg)
	a	b	c	d	e	f	g	h	i	j	k	L	m	n	r	径	本	径	本	
30-6	300	260	300	80	50	80	300	50	10	55	10	600	90	60	50	3.2	9	4.0	5	98
30-10	300	260	300	80	50	80	300	50	10	55	10	1000	90	60	50	3.2	9	4.0	8	163
30-20	300	260	300	80	50	80	300	50	10	55	10	2000	90	60	50	3.2	6	4.0	16	326
36-10	360	310	360	80	50	80	360	50	10	55	10	1000	95	65	50	4.0	11	4.0	13	204

# 鉄筋コンクリート片肉厚U形

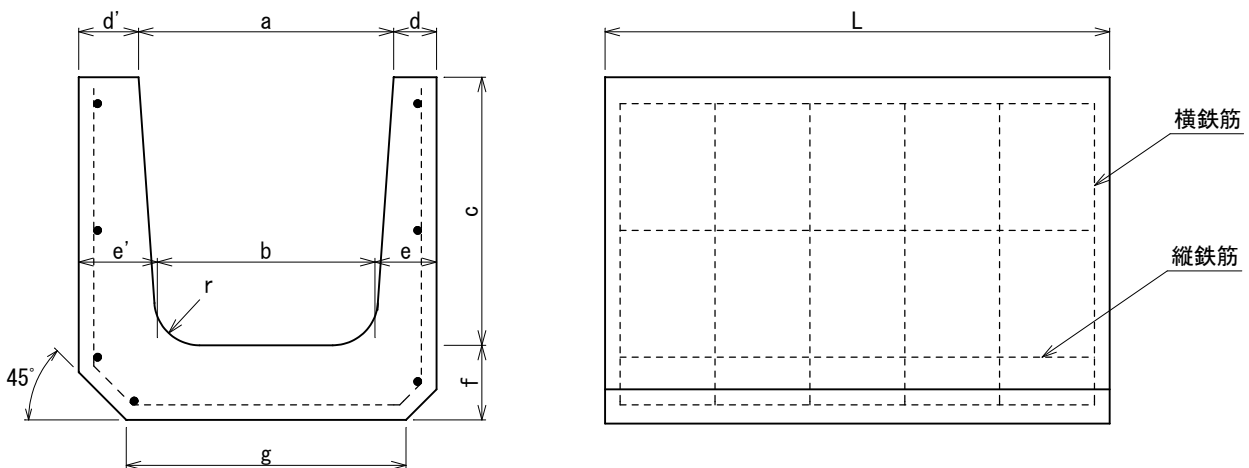

呼び名	寸法 (mm)											縦鉄筋		横鉄筋		補強筋		参考重量 (kg)
	a	b	c	d	d'	e	e'	f	g	r	L	径	本	径	本	径	本	
240	240	220	240	45	65	50	80	70	270	50	600	6	7	6	7	—	—	71
300	300	260	300	50	70	60	100	80	340	50	600	6	9	9	7	—	—	108
450	450	400	450	55	75	70	110	90	470	70	600	6	13	9	7	—	—	185
600	600	540	600	70	85	80	135	100	650	70	600	6	15	9	9	6	5	280

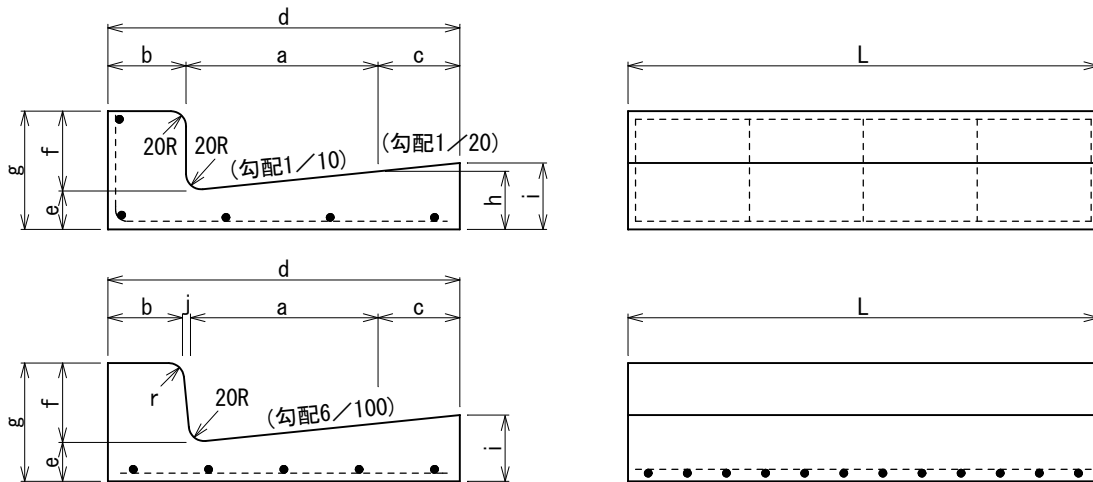

呼び名	寸法 (mm)												縦鉄筋		横鉄筋		参考重量 (kg)	
	a	b	c	d	e	f	g	h	i	j	r	L	径	本	径	本		
鉄筋 コンクリート L形	250A	250	100	—	350	55	100	155	80	—	—	—	600	4.0	4	4.0	5	47
	250B	250	100	100	450	55	100	155	80	85	—	—	600	4.0	5	4.0	5	58
	300	300	100	100	500	55	100	155	85	90	—	—	600	4.0	5	4.0	6	65
	350	350	100	100	550	55	100	155	90	95	—	—	600	4.0	5	6.0	5	72
鉄筋 コンクリート L形	500A	500	150	—	665	120	150	270	—	150	15	20	2000	D6	5	D6	12	538
	500B	500	180	—	700	120	200	320	—	150	20	30	2000	D6	5	D6	12	632
	500C	500	180	—	705	120	200	370	—	150	25	30	2000	D6	5	D6	12	688

## 鉄筋コンクリートL形切下

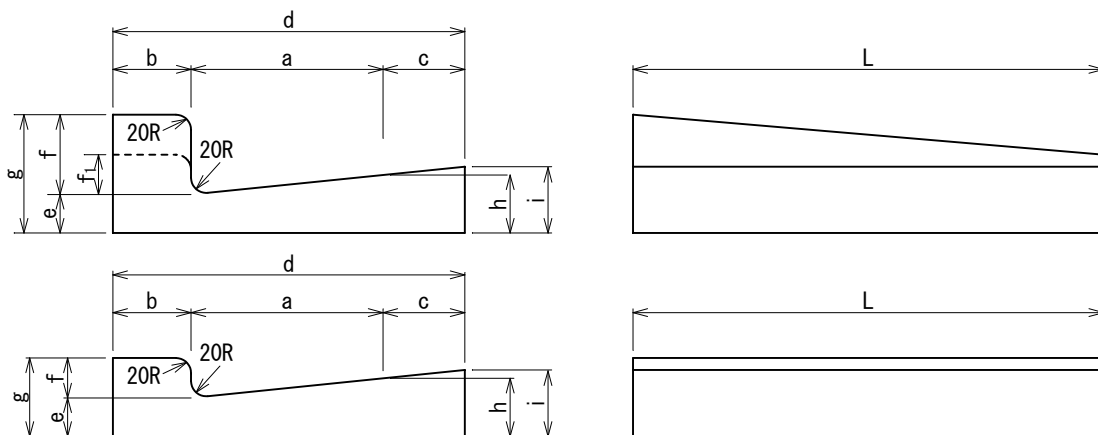

呼び名	寸法 (mm)												縦鉄筋		横鉄筋		参考重量 (kg)
	a	b	c	d	e	f	f <sub>1</sub>	g	h	i	L	径	本	径	本		
鉄筋 コンクリート L形 切下斜	250A	250	100	—	350	55	100	50	155	80	—	600	4.0	4	4.0	5	43
	250B	250	100	100	450	55	100	50	155	80	85	600	4.0	5	4.0	5	55
	300	300	100	100	500	55	100	50	155	85	90	600	4.0	5	4.0	6	62
	350	350	100	100	550	55	100	50	155	90	95	600	4.0	5	6.0	5	68
鉄筋 コンクリート L形 切下平	250A	250	100	—	350	55	50	—	105	80	—	600	4.0	4	4.0	5	40
	250B	250	100	100	450	55	50	—	105	80	85	600	4.0	5	4.0	5	51
	300	300	100	100	500	55	50	—	105	85	90	600	4.0	5	4.0	6	60
	350	350	100	100	550	55	50	—	105	90	95	600	4.0	5	6.0	5	63



## 250用L型縁塊

(W = 63 kg)

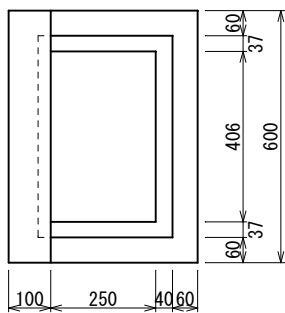

## 300用L型縁塊

(W = 66 kg)

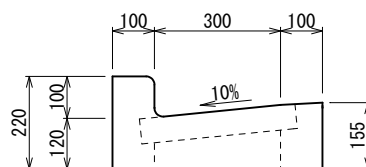
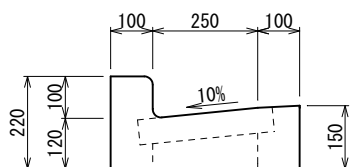
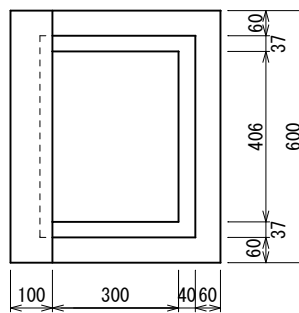

## グレーチングふた

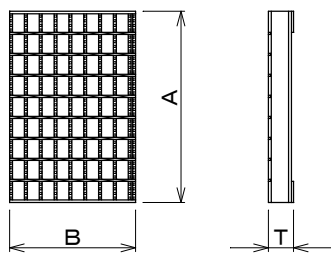

	グレーチングふた			
	A	B	T	参考重量
250用	455	300	60	12.4kg
300用	460	350	60	14.0kg

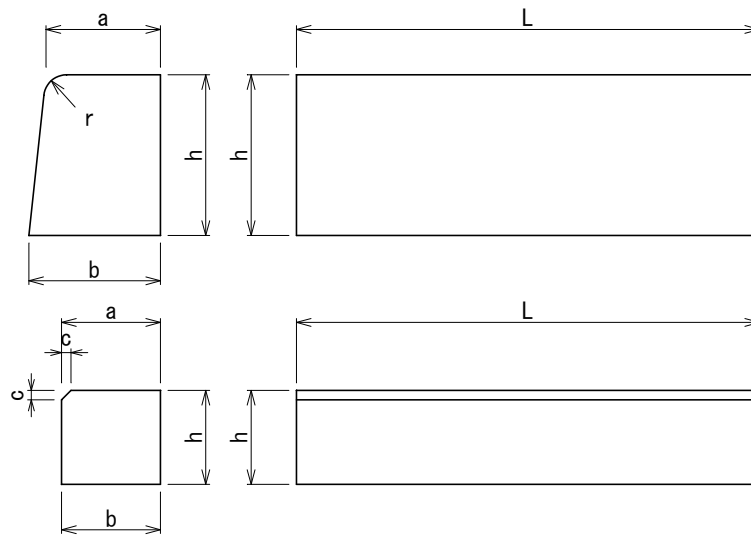

呼 び 名	寸 法 (mm)						参考重量 (kg)
	a	b	h	c	r	L	
歩車道境界 A	150	170	200	—	20	600	44
〃 B	180	205	250	—	30	600	66
〃 C	180	210	300	—	30	600	81
地先境界 A (面有)	120	120	120	10	—	600	20
〃 B (面有)	150	150	120	10	—	600	25
〃 C (面有)	150	150	150	10	—	600	31
地先境界 A (面無)	120	120	120	—	—	600	20
〃 B (面無)	150	150	120	—	—	600	25
〃 C (面無)	150	150	150	—	—	600	31

## 歩車道境界ブロック曲

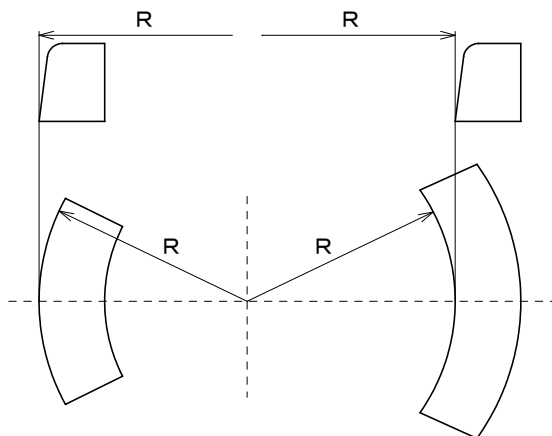

半径 R (m)	1/4 用 (90°)		1/2 用 (180°)	
	曲線長さ (m)	使用本数	曲線長さ (m)	使用本数
0.25	0.393	0.7	0.785	1.3
0.5	0.785	1.3	1.570	2.6
0.75	1.178	2.0	2.355	3.9
1.0	1.570	2.6	3.140	5.2
1.5	2.355	3.9	4.710	7.8
2.0	3.140	5.2	6.280	10.4
2.5	3.925	6.5	7.850	13.1
3.0	4.710	7.3	9.420	15.7
4.0	6.280	10.4	12.560	20.9
5.0	7.850	13.1	15.700	26.2
6.0	9.420	15.7	18.840	31.4
8.0	12.560	20.9	25.120	41.9
10.0	15.700	26.2	31.400	52.3

\*歩 B 及び歩 C のみ

# 歩車道境界ブロック切下

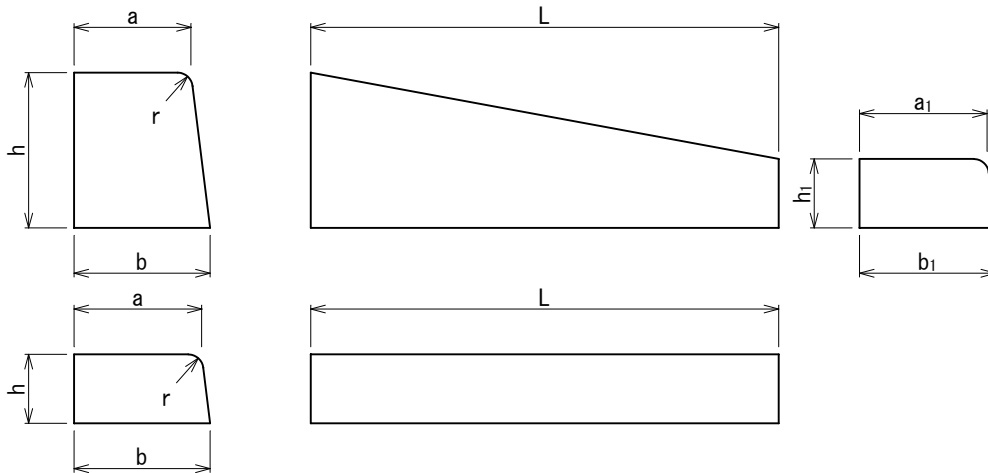

呼び名	寸法 (mm)								参考重量 (kg)	
	a	a <sub>1</sub>	b	b <sub>1</sub>	h	h <sub>1</sub>	r	L		
切下斜	A	150	160 (163)	170	170	200	100 (70)	20	600	39 (34)
	B	180	195 (198)	205	205	250	100 (70)	30	600	48 (44)
	C	180	200 (203)	210	210	300	100 (70)	30	600	55 (51)
乗入平	A	160 (163)	—	170	—	100 (70)	—	20	600	23 (16)
	B	195 (198)	—	205	—	100 (70)	—	30	600	28 (20)
	C	200 (203)	—	210	—	100 (70)	—	30	600	29 (20)

# 歩車道境界ブロック切下 (身障者用)

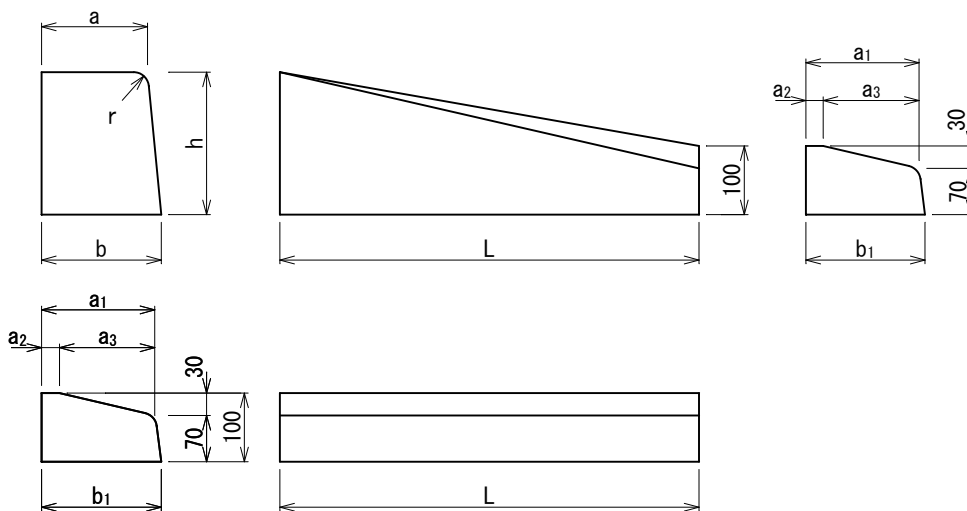

呼び名	寸法 (mm)									参考重量 (kg)	
	a	a <sub>1</sub>	a <sub>2</sub>	a <sub>3</sub>	b	b <sub>1</sub>	h	r	L		
斜	A	150	163	60	103	170	170	200	20	600	32
	B	180	200	65	135	205	205	250	30	600	46
	C	180	200	65	135	210	205	300	30	600	54
平	A	—	163	60	103	—	170	—	—	600	21
	B	—	200	65	135	—	205	—	—	600	26



# 歩車道境界末端ブロック

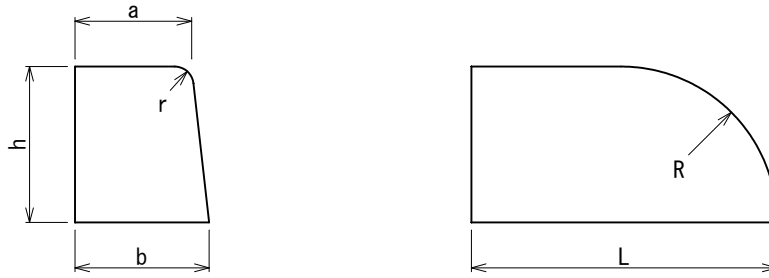

呼 び 名	寸 法 (mm)						参考重量 (kg)
	a	b	h	r	R	L	
端 末 A	150	170	200	20	200	600	41
端 末 B	180	205	250	30	250	600	61
端 末 C	180	210	300	30	300	600	73

# 街渠柵

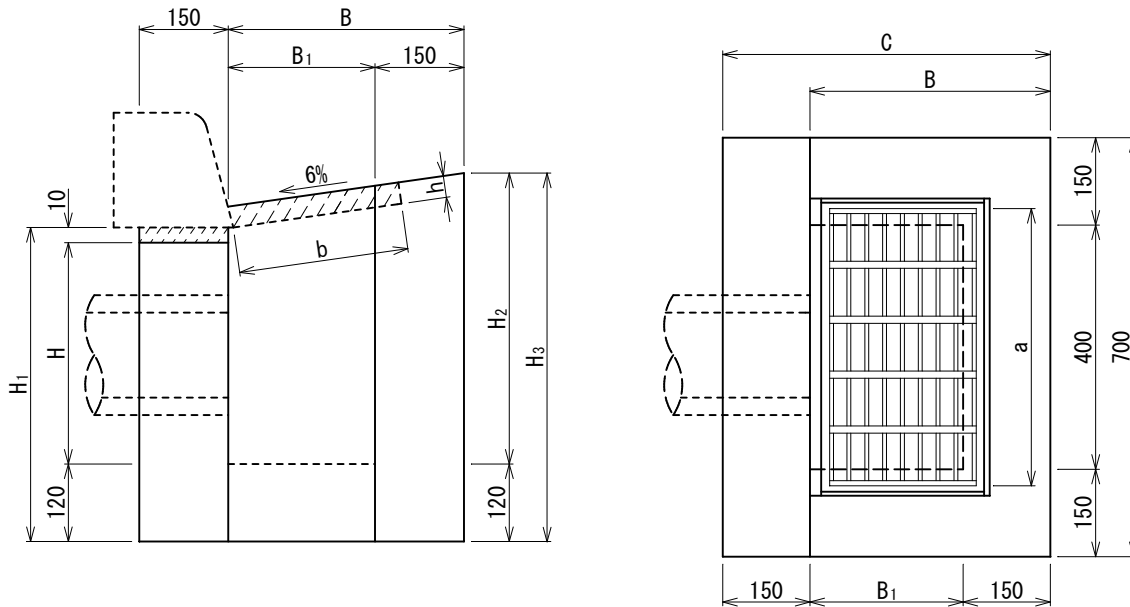

呼 び 名	柵 寸 法 (mm)							参考重量 (kg)	グレーチング寸法 (mm)			参考重量 (kg)
	B	B <sub>1</sub>	C	H	H <sub>1</sub>	H <sub>2</sub>	H <sub>3</sub>		a	b	h	
B 400-H 300	400	250	550	300	430	384	504	350	500	289	50	10.2
B 400-H 400	400	250	550	400	530	484	604	420	500	289	50	10.2
B 400-H 500	400	250	550	500	630	584	704	490	500	289	50	10.2

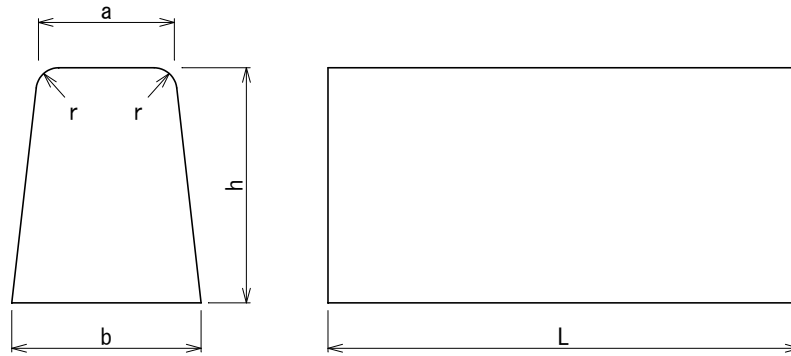

呼び名	寸法(mm)					参考重量 (kg)	水抜寸法	参考重量 (kg)	寸法(mm)	参考重量 (kg)
	a	b	h	r	L		h <sub>2</sub>		L	
A 型	150	190	200	20	600	48	125	32	995	80
B 型	180	230	250	30	600	72	150	53		
C 型	180	240	300	30	600	88	150	65		

\*但し水抜きはL=600のみです。

## 排水ブロック (水抜)

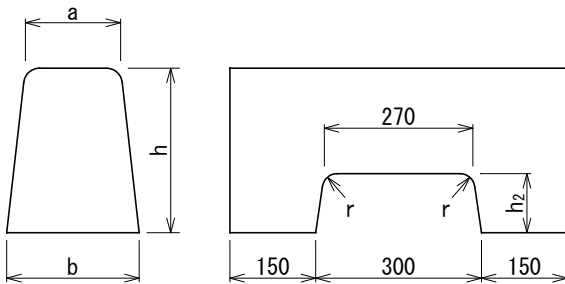

## 端末ブロック

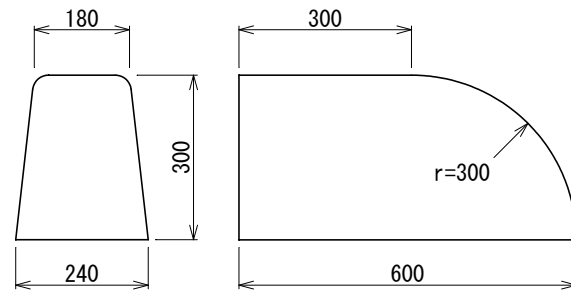

参考重量 81kg

## 反射付端末ブロック

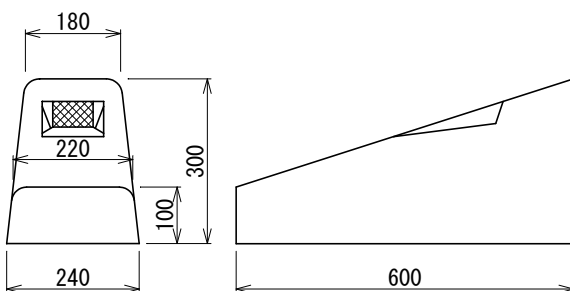

参考重量 60kg

## 端部反射付ブロック

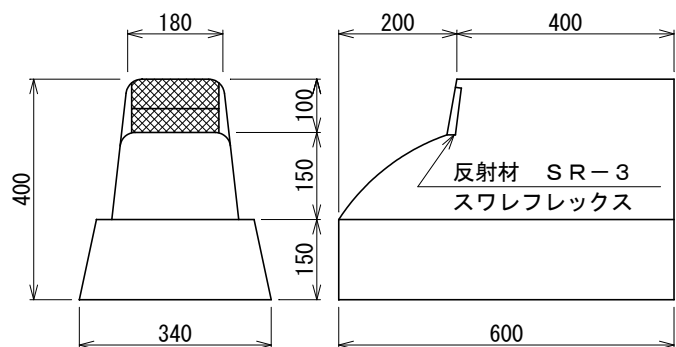

参考重量 123kg

# 両面歩車道境界ブロック切下



切下(斜)

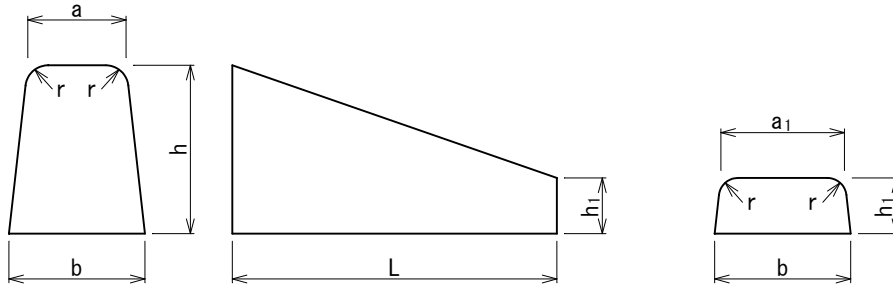

呼び名	寸法 (mm)							参考重量 (kg)
	a	a <sub>1</sub>	b	h	h <sub>1</sub>	r	L	
A	150	176	190	200	70	20	600	33
B	180	216	230	250	70	30	600	47
	180	210	230	250	100	30	600	51
C	180	226	240	300	70	30	600	55
	180	220	240	300	100	30	600	60

乗入(平)

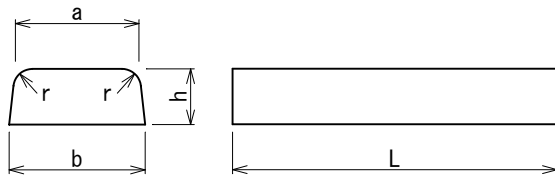

呼び名	寸法 (mm)					参考重量 (kg)
	a	b	h	r	L	
A	176	190	70	20	600	18
B	216	230	70	30	600	21
	210	230	100	30	600	30
C	226	240	70	30	600	22
	220	240	100	30	600	32

# 両面A身障害者用切下ブロック

切下(斜)

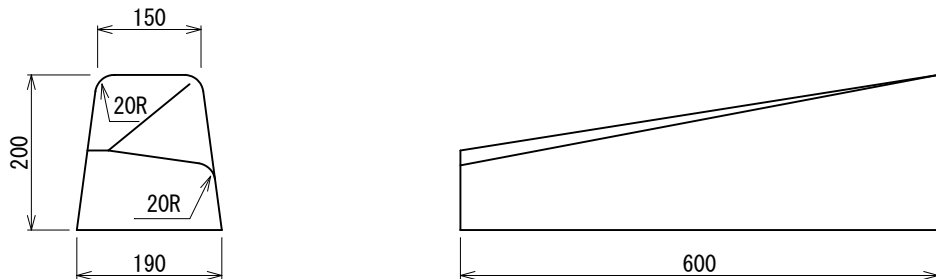

参考重量 36kg

乗入(平)

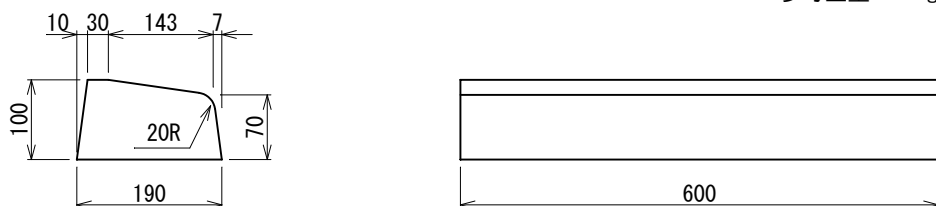

参考重量 25kg

# ベース付歩車道境界ブロック：A型



## 基本

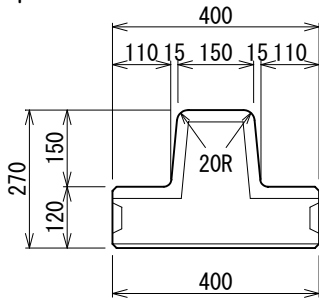

参考重量 340kg

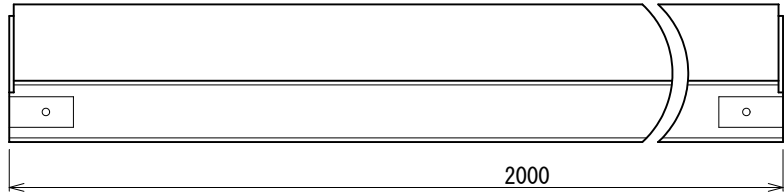

## 水抜き

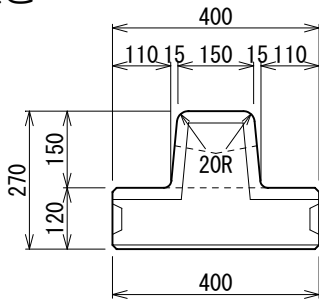

参考重量 331kg

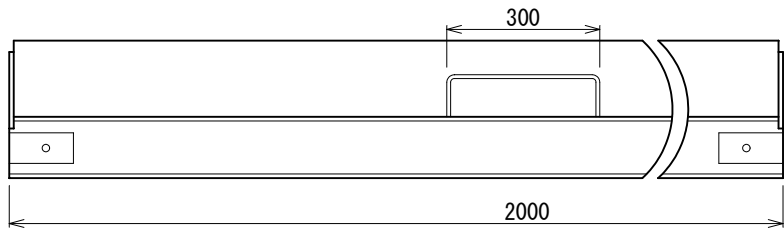

## 切下げ

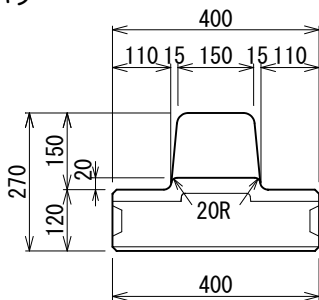

参考重量 326kg

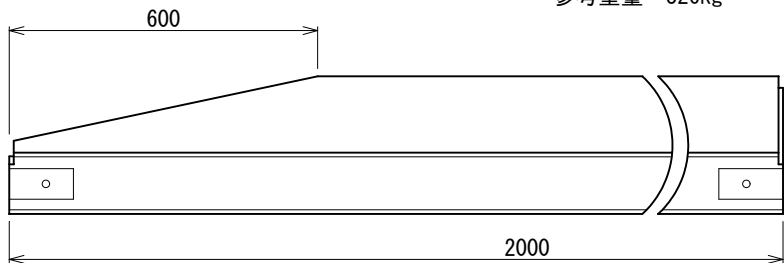

## 反射付切下げ

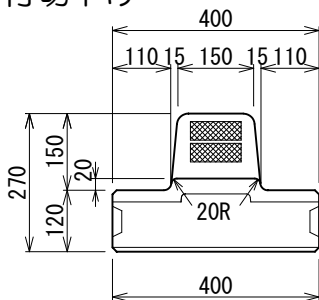

参考重量 325kg

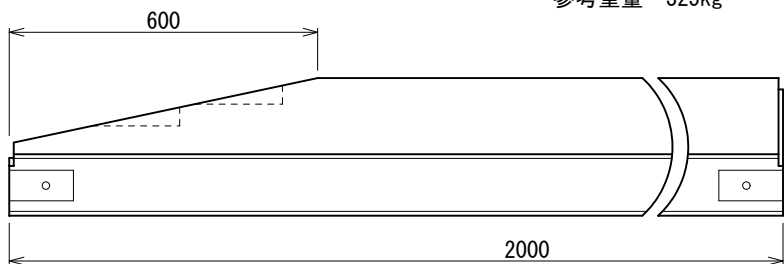

## 乗入れ

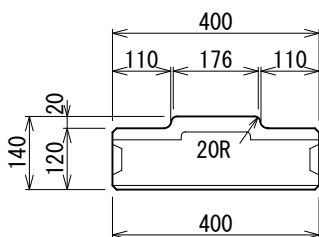

参考重量 241kg

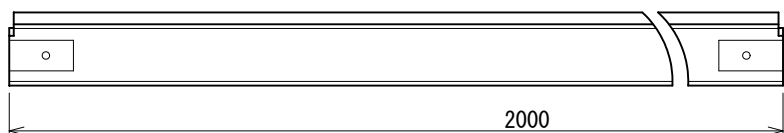

# ベース付歩車道境界ブロック：C型



## 基本

参考重量 555kg

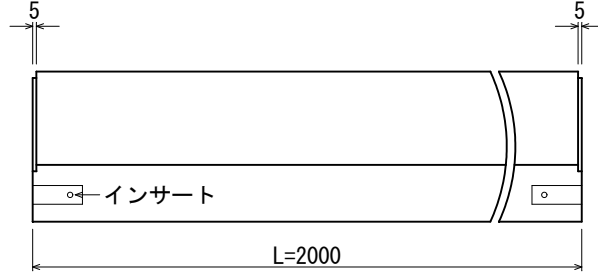
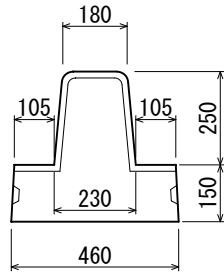

## 水抜き

参考重量 537kg

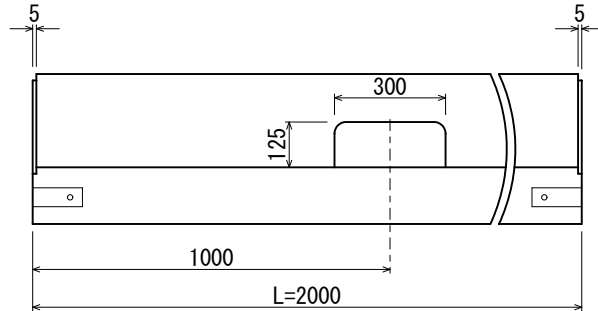
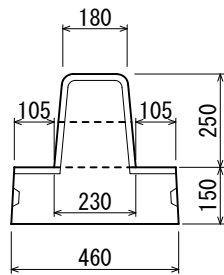

## 入口

参考重量 516kg

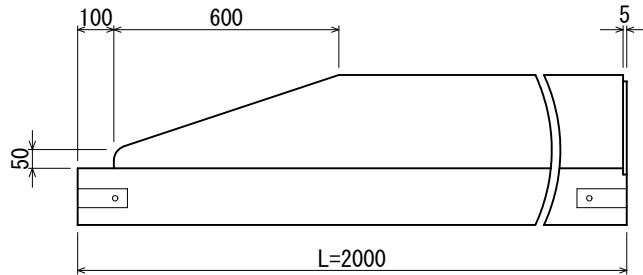
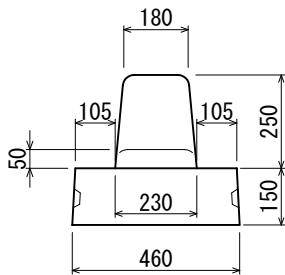

## 入口反射

参考重量 513kg

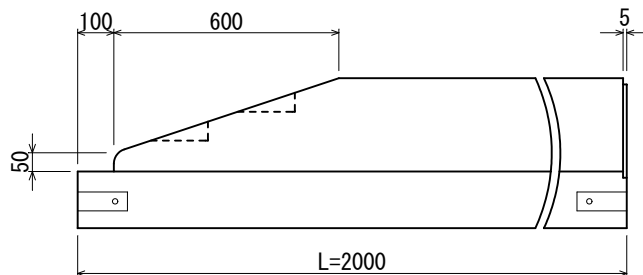
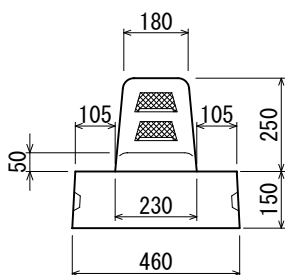

# L形街渠：A-15（両面）



## 基本

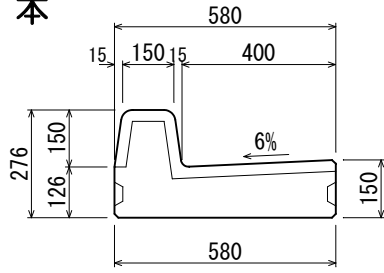

参考重量 484kg

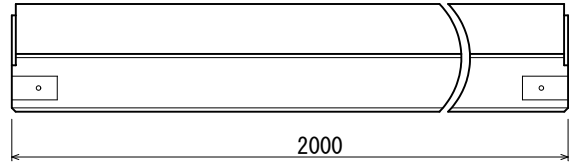

## 水抜き

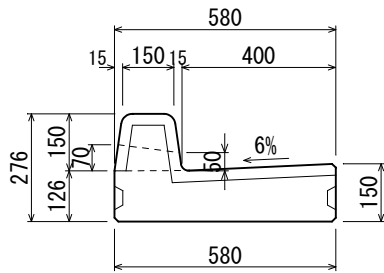

参考重量 478kg

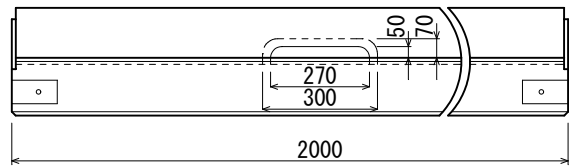

## 切下げ（右・左）

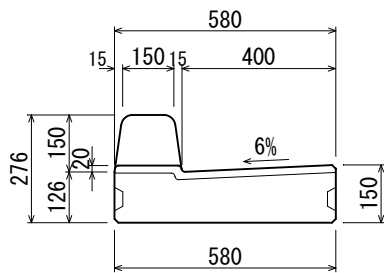

参考重量 470kg

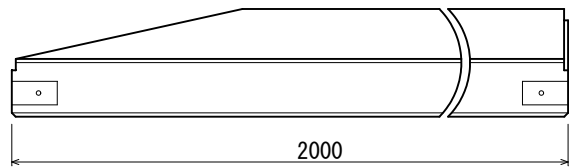

## 切下げ（反射）（右・左）

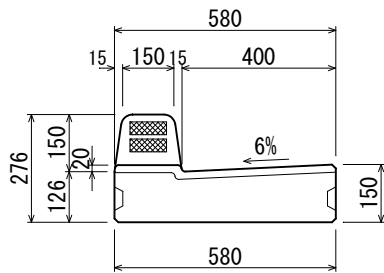

参考重量 469kg

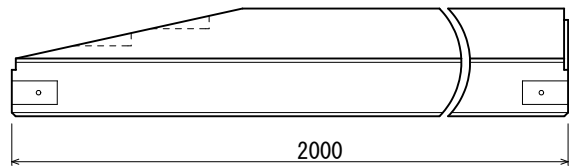

## 乗入れ

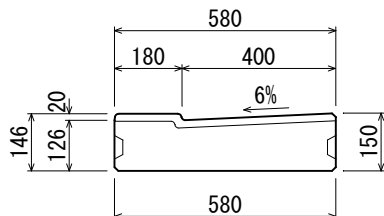

参考重量 384kg

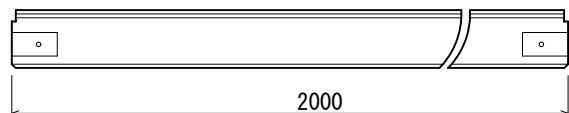

# L形街渠：A-15（両面）



## セミフラット切下げ（右・左）

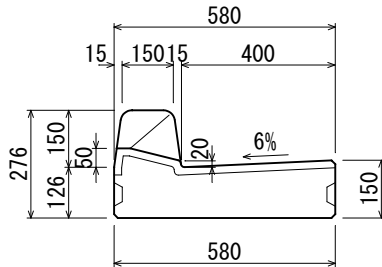

参考重量 472kg

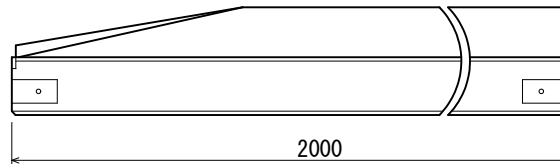

## セミフラット乗入れ

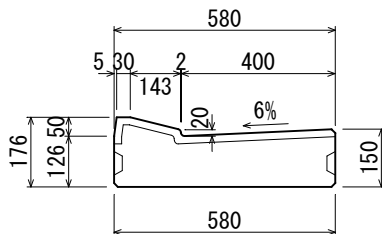

参考重量 400kg

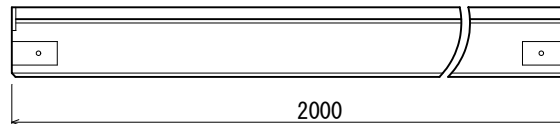

## 縁塊

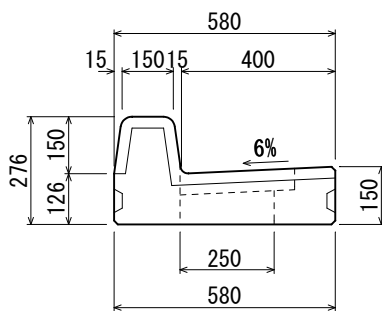

参考重量 221kg

グレーチング110° 回転

参考重量 11.2kg

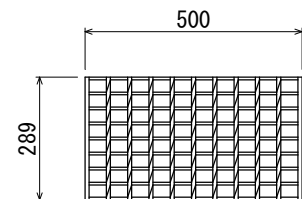
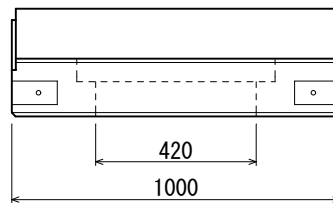

## 集水枡 B400-H444 (544)

参考重量 317kg (388) kg

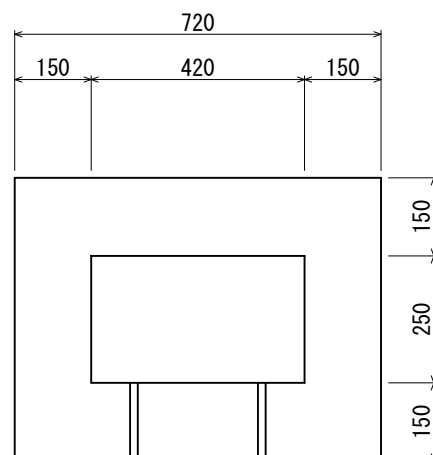
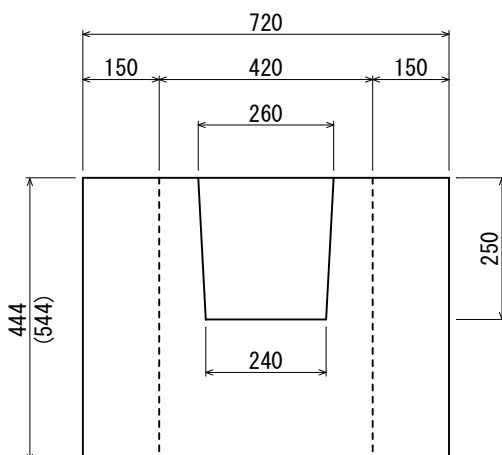

# L形街渠：A-15（片面）



## 基本

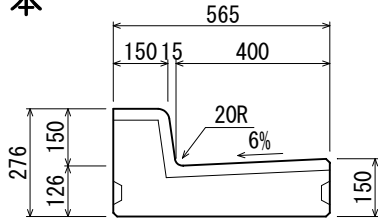

参考重量 470kg

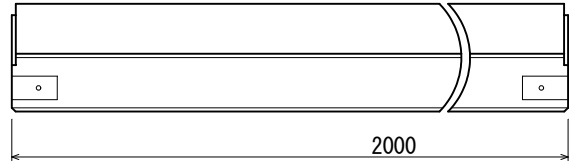

## 切下げ（右・左）

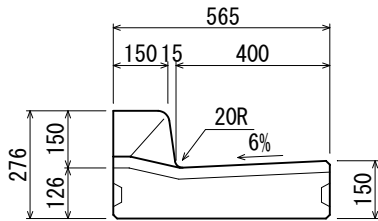

参考重量 456kg

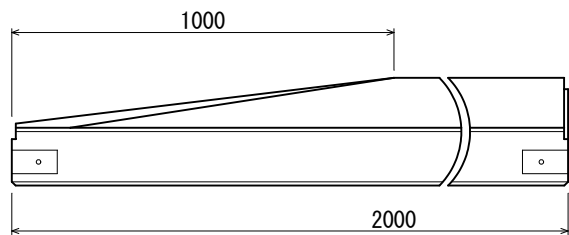

## 乗入れ

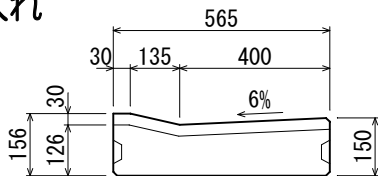

参考重量 374kg

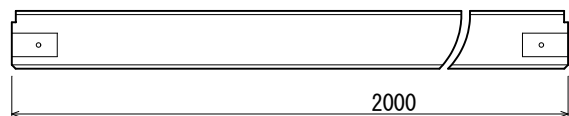



# L型街渠：A-15（片面）



## 縁 塊

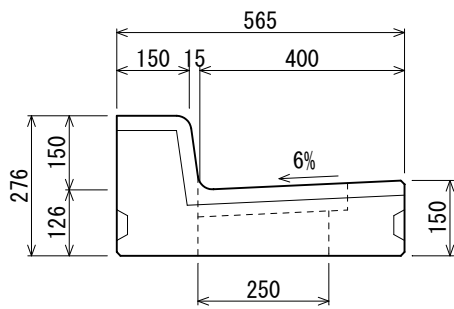

参考重量 214kg

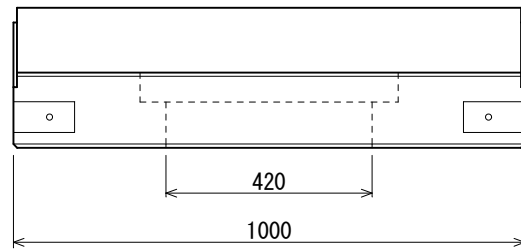

グレーチング110° 回転  
参考重量 11.2kg

グレーチング110° 回転 参考重量 11.2kg

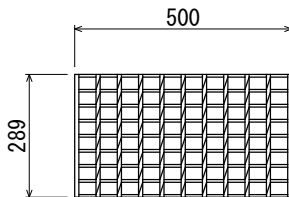

## 集水柵 B400-H444 (544)

参考重量 317kg (388) kg

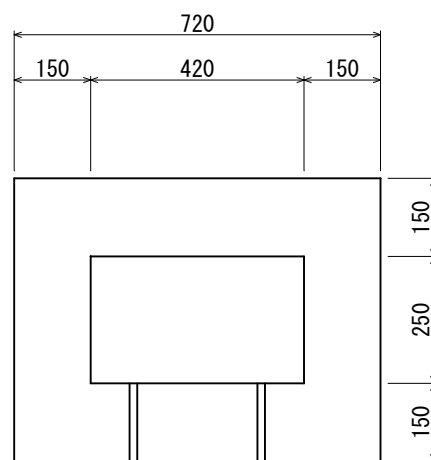
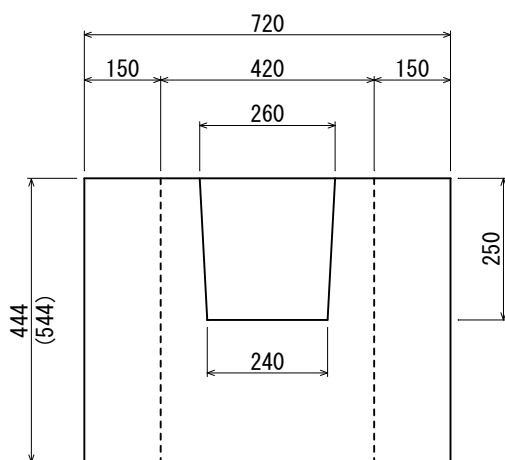

# エプロン付歩車道境界ブロック：C-15



## 基本

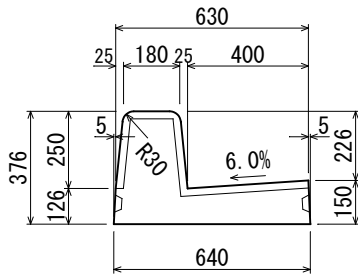

参考重量 648kg

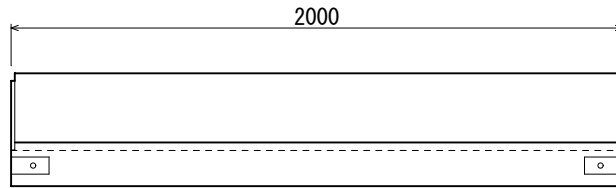

## 水抜き

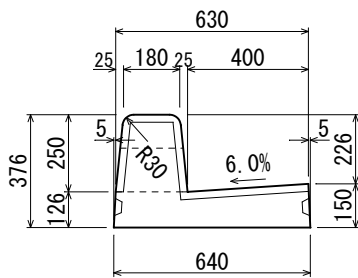

参考重量 629kg

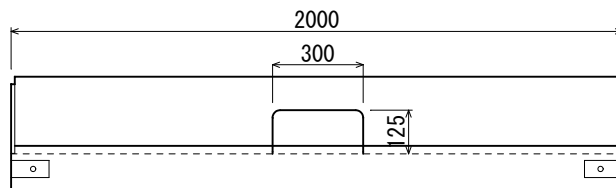

## 切下斜

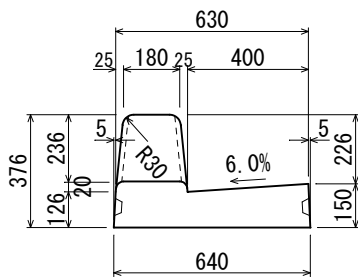

参考重量 612kg

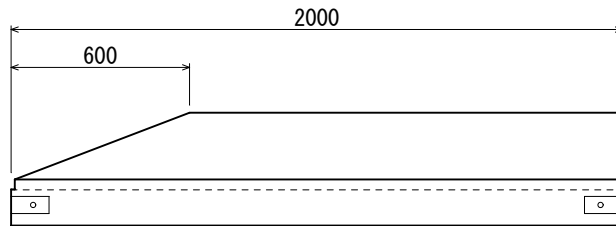

## 切下斜（反射）

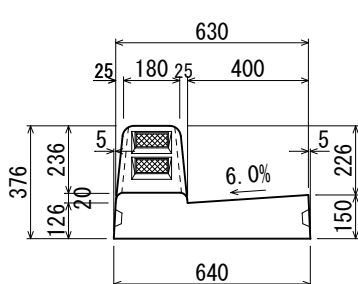

参考重量 609kg

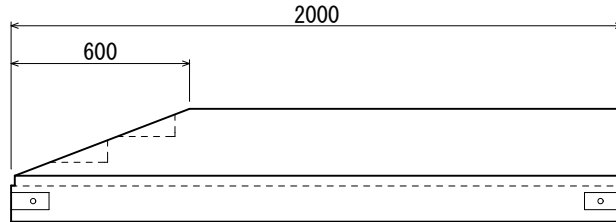

## 乗入（平）

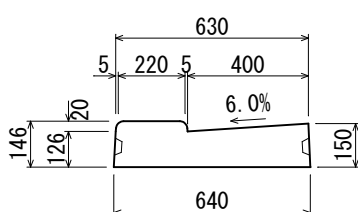

参考重量 450kg

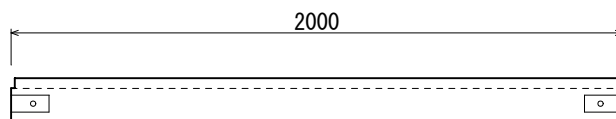



## 縁 塊

参考重量 301kg

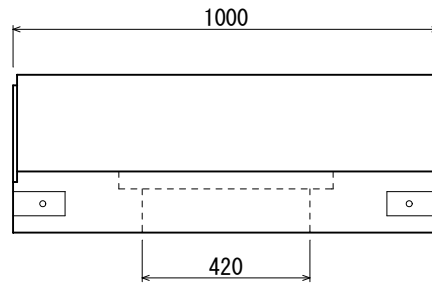
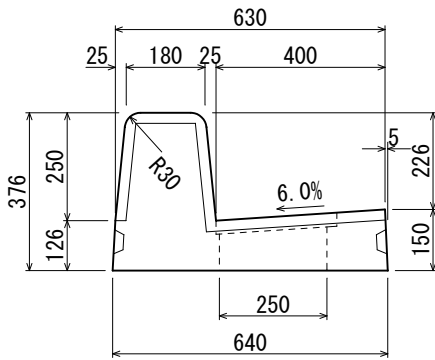

グレーチング110° 回転 参考重量 11.2kg

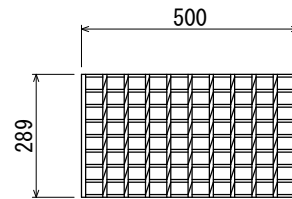

## 集水枡 B400-H444 (544)

参考重量 317kg (388) kg

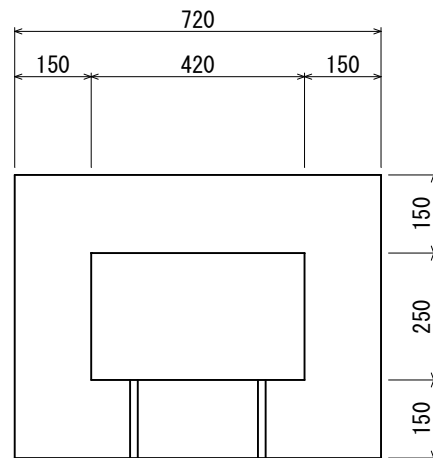
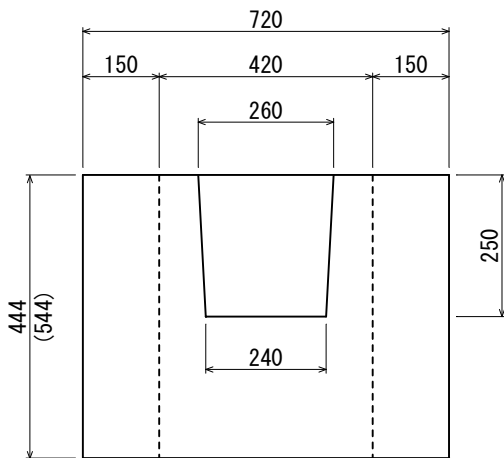

# エプロン付歩車道境界ブロック：C-15（底版張出型）



## 基本

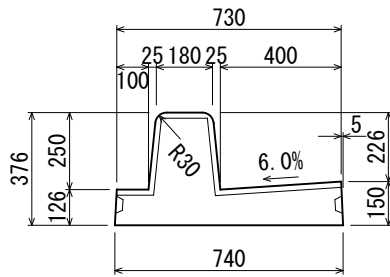

参考重量 710kg

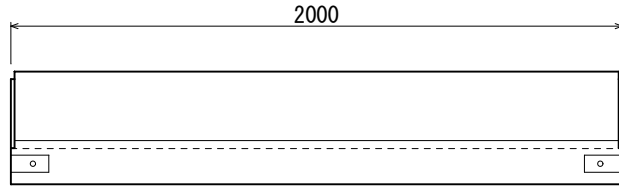

## 水抜き

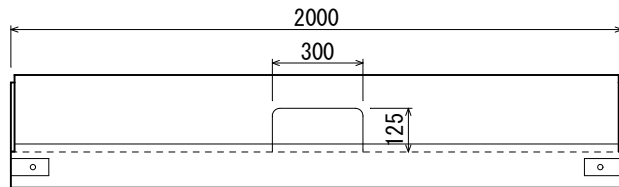
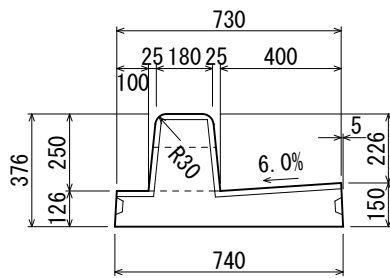

## 切下斜

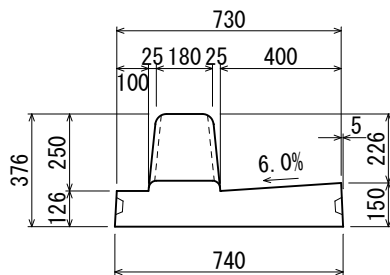

参考重量 674kg

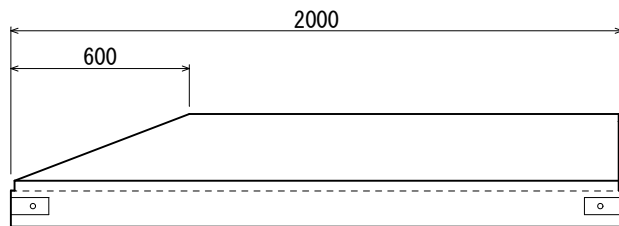

## 切下斜（反射）

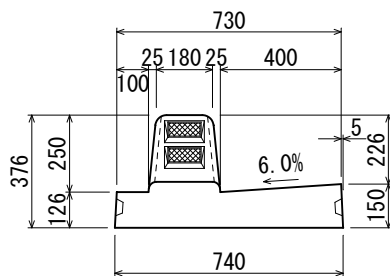

参考重量 671kg

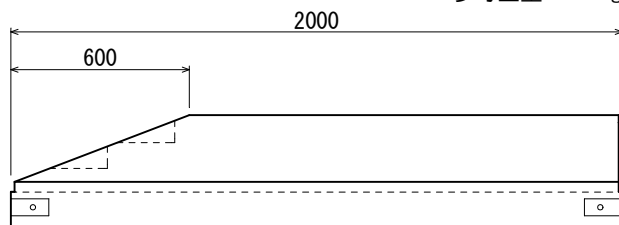

## 乗入（平）

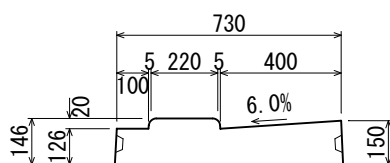

参考重量 512kg

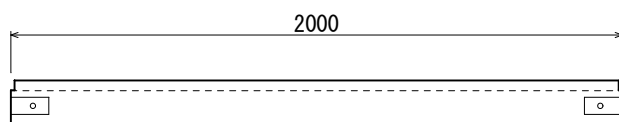



## 縁 塊

参考重量 333kg

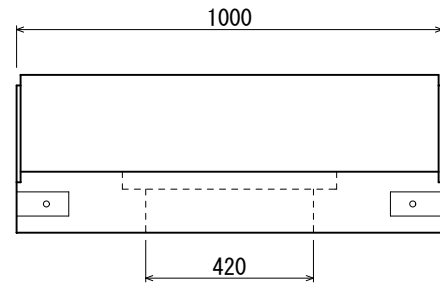
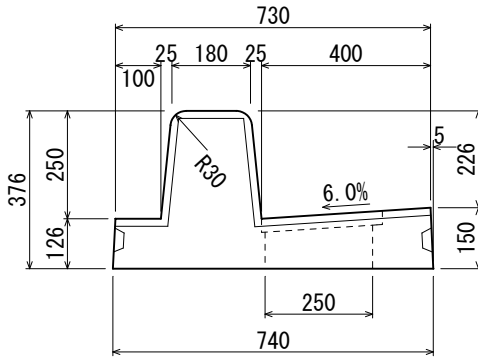

グレーチング110° 回転 参考重量 11.2kg

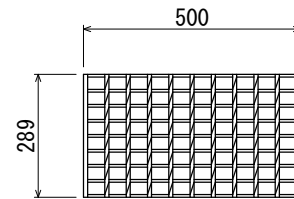

## 集水柵 B400-H444 (544)

参考重量 317kg (388) kg

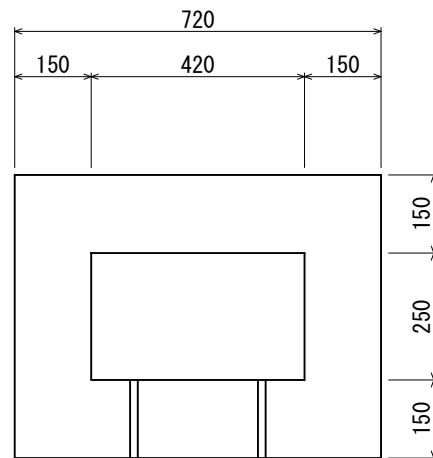
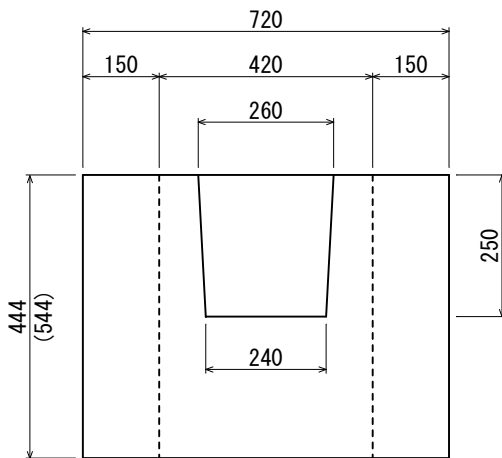

# 中央分離帯ブロック



片面：基本

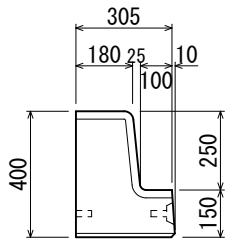

参考重量 453kg

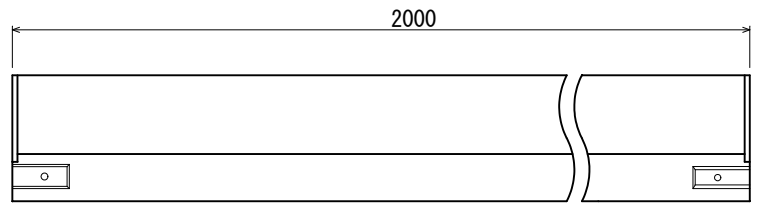

片面：水抜き

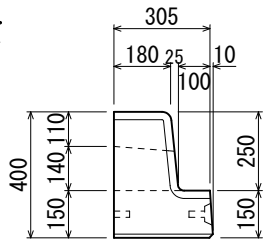

参考重量 435kg

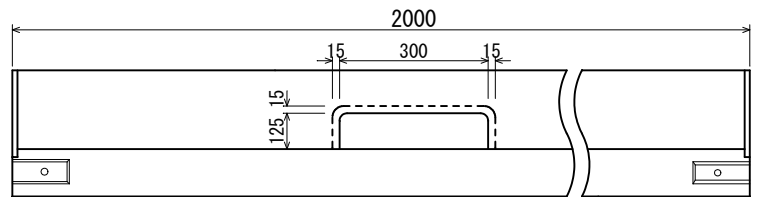

両面：基本

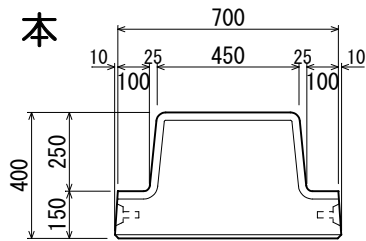

参考重量 1057kg

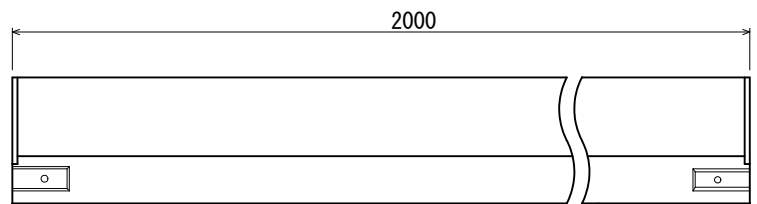

両面：水抜き

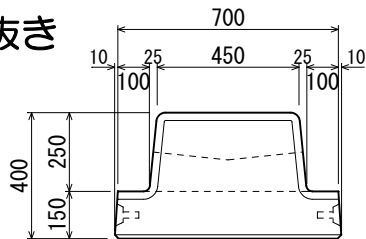

参考重量 1021kg

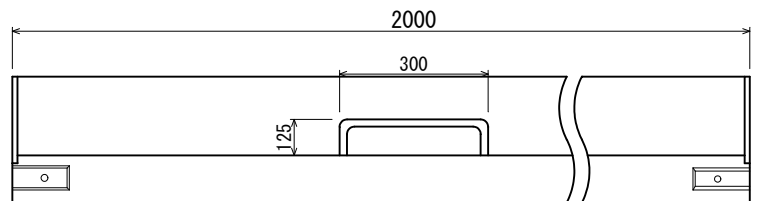

端部

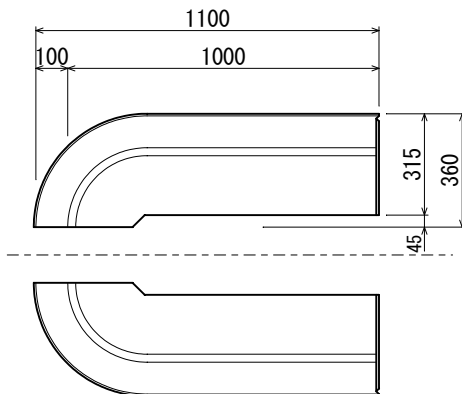

参考重量 229kg

側面図

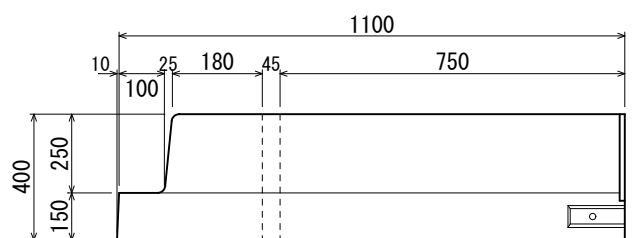

# L型街渠用ブロック

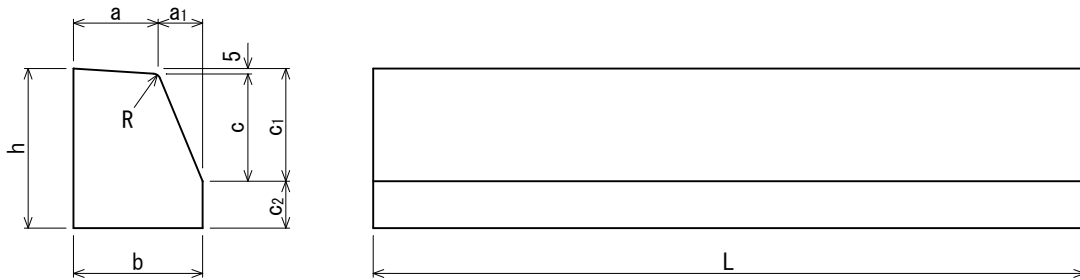

呼び名	寸法 (mm)									参考重量 (kg)
	a	a <sub>1</sub>	b	c	c <sub>1</sub>	c <sub>2</sub>	h	R	L	
A 型	120	60	180	150	—	70	225	20	990	85
B 型	100	50	150	—	100	50	150	10	600	29

## L型用境界ブロック切下げ

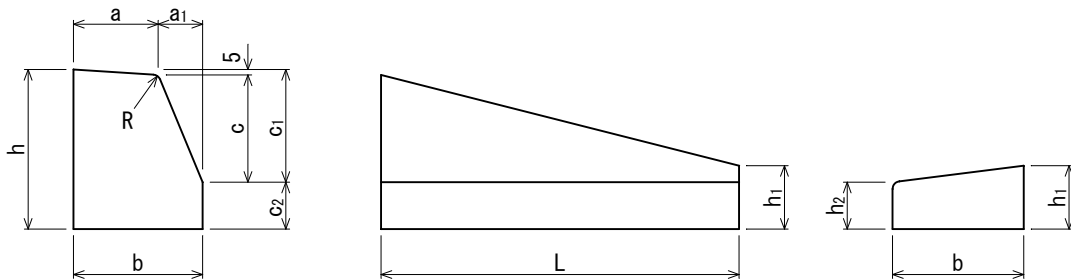

呼び名	寸法 (mm)										参考重量 (kg)	
	a	a <sub>1</sub>	b	c	c <sub>1</sub>	c <sub>2</sub>	h	h <sub>1</sub>	h <sub>2</sub>	R		L
A 型	120	60	180	150	—	70	225	100	70	20	500	35
B 型	100	50	150	—	100	50	150	80	60	10	470	17

## L型用境界ブロック乗入れ

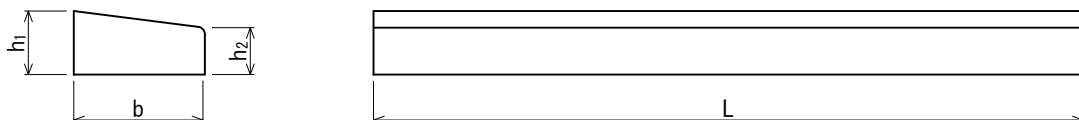

呼び名	寸法 (mm)				参考重量 (kg)
	b	h <sub>1</sub>	h <sub>2</sub>	L	
A 型	180	100	70	990	36
B 型	150	80	60	600	15

# 並木ます用コンクリートブロック



## 並木ますブロック

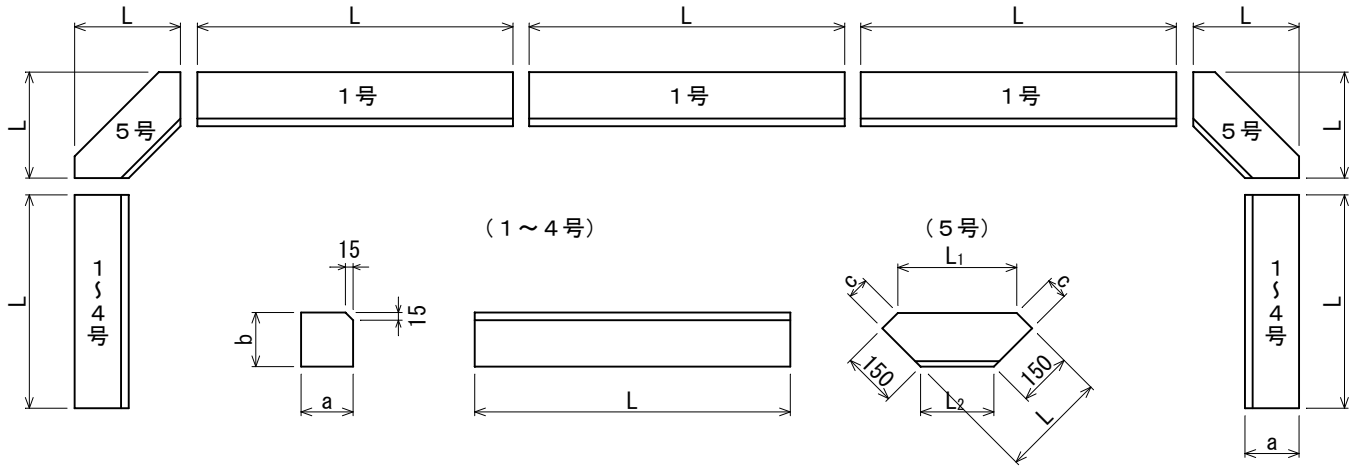

呼 び 名	寸 法 (mm)							参考重量 (kg)
	a	b	c	L	L <sub>1</sub>	L <sub>2</sub>		
並木ます用ブロック	1号	150	180	—	900	—	—	57
	2号	150	180	—	600	—	—	38
	3号	150	180	—	450	—	—	29
	4号	150	180	—	300	—	—	19
	5号	150	180	60	300	340	210	21

## 車止めブロック

車止めブロック（模様あり） 重量 20kg

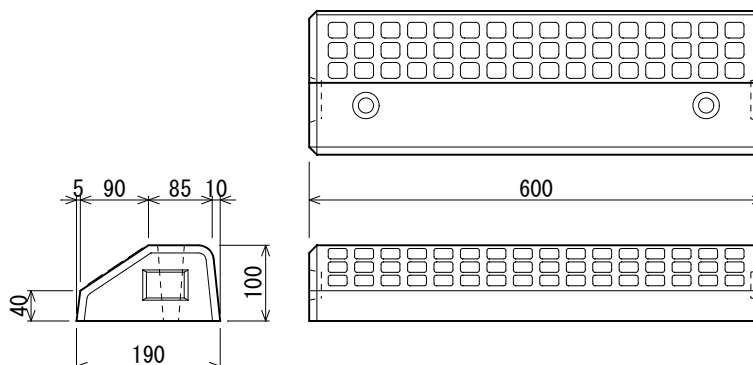



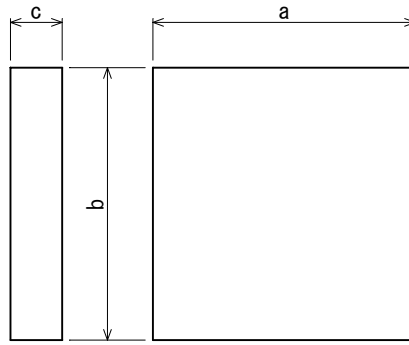

呼び名	寸法 (mm)			参考重量 (kg)
	a	b	c	
300	300	300	60	13

## コンクリート特殊境界ブロック

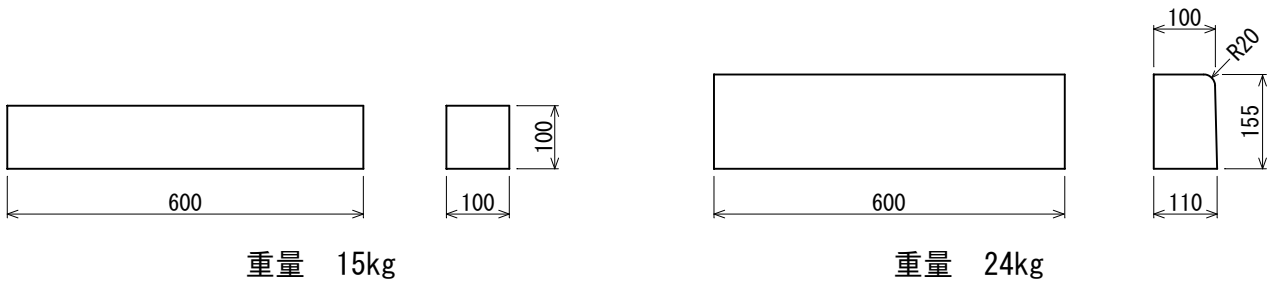

## V形溝

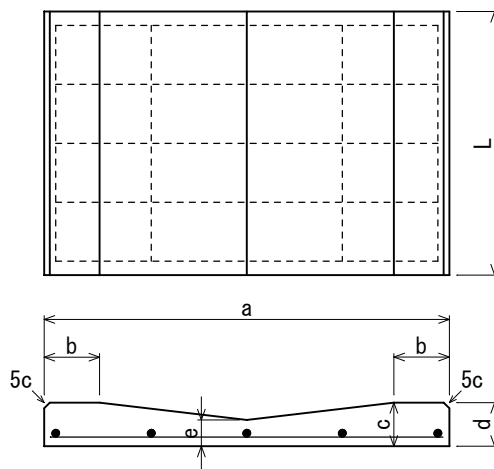

呼び名	寸法 (mm)						縦鉄筋		横鉄筋		参考重量 (kg)
	a	b	c	d	e	L	径	本	径	本	
VB-250	700	100	80	85	55	500	6	5	6	5	59
Vt-250	500	—	—	80	55	500	6	5	6	5	40

# 水止めブロック

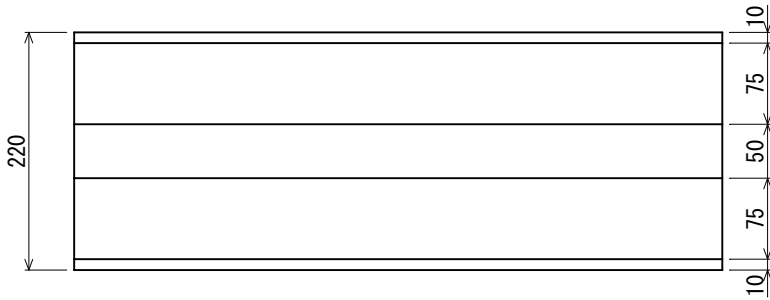

参考重量 : 26kg

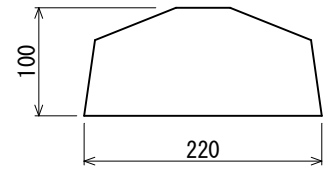
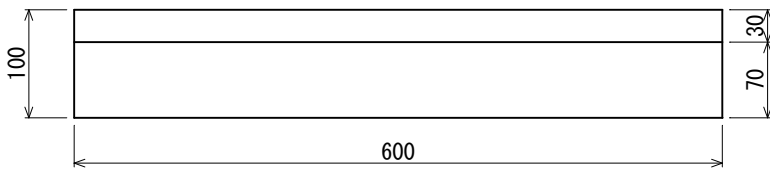

# 止水駒

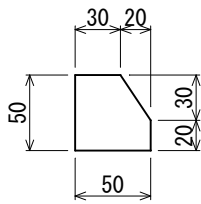

参考重量 : 3kg

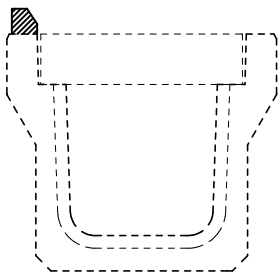
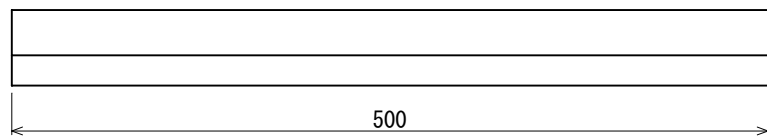

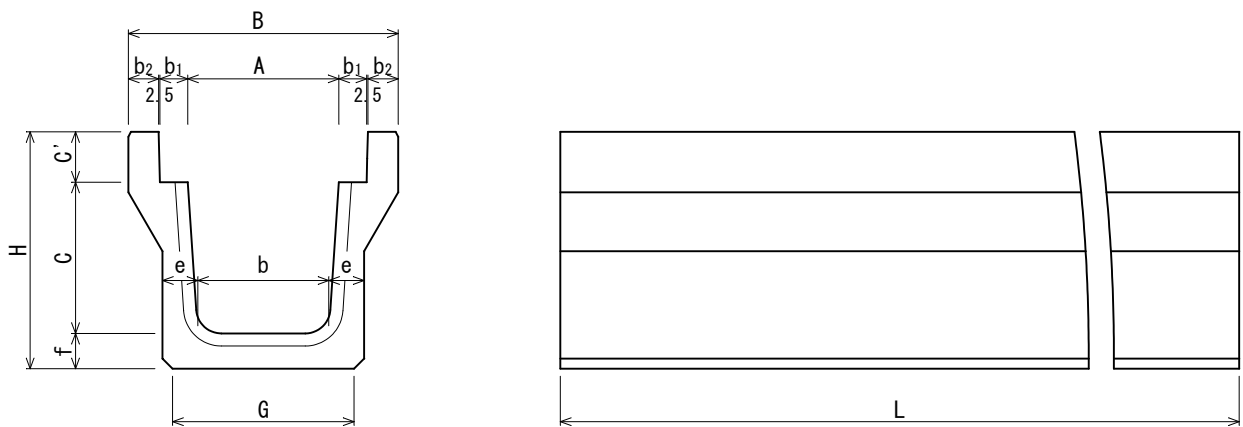

## GPU2型（歩道用）

JIS A 5372 1種参考

呼び名	寸法 (mm)												参考重量 (kg)
	A	C	B	b	b <sub>1</sub>	b <sub>2</sub>	C'	e	f	G	H	L	
GPU2-250	250	250	485	230	55	60	90	55	55	300	395	2000	320
GPU2-303	300	300	535	280	55	60	100	60	60	360	460	2000	383
GPU2-304	300	400	535	270	55	60	100	65	65	360	565	2000	455
GPU2-305	300	500	535	260	55	60	100	70	70	360	670	2000	531
GPU2-404	400	400	635	370	55	60	110	65	65	460	575	2000	492
GPU2-405	400	500	635	360	55	60	110	70	70	460	680	2000	571
GPU2-450	450	450	675	400	50	60	110	75	75	490	635	2000	575
GPU2-505	500	500	755	460	60	65	125	70	70	560	695	2000	634
GPU2-506	500	600	755	450	60	65	125	75	75	560	800	2000	720
GPU2-606	600	600	875	540	60	75	130	95	95	600	825	2000	942
GPU2-707	700	700	975	640	60	75	120	90	90	720	910	2000	1039
GPU2-807	800	700	1095	740	70	75	120	90	90	820	910	2000	1101
GPU2-808	800	800	1095	720	70	75	120	100	100	820	1020	2000	1272
GPU2-909	900	900	1195	830	70	75	140	100	100	900	1140	2000	1404
GPU2-1010	1000	1000	1315	920	80	75	150	110	110	1040	1260	2000	1689

## GPU3型（車道用）

JIS A 5372 3種参考

呼び名	寸法 (mm)												参考重量 (kg)
	A	C	B	b	b <sub>1</sub>	b <sub>2</sub>	C'	e	f	G	H	L	
GPU3-250	250	250	485	230	55	60	90	65	65	300	405	2000	354
GPU3-303	300	300	535	280	55	60	100	70	70	360	470	2000	425
GPU3-304	300	400	535	270	55	60	100	70	70	330	570	2000	481
GPU3-305	300	500	535	260	55	60	100	80	80	340	680	2000	594
GPU3-404	400	400	635	370	55	60	110	70	70	430	580	2000	520
GPU3-405	400	500	635	360	55	60	110	80	80	440	690	2000	638
GPU3-450	450	450	675	400	50	60	110	75	75	490	635	2000	575
GPU3-505	500	500	755	460	60	65	125	80	80	540	705	2000	704
GPU3-506	500	600	755	450	60	65	125	90	90	550	815	2000	842
GPU3-606	600	600	875	540	60	75	130	95	95	600	825	2000	942
GPU3-707	700	700	975	640	60	75	120	90	90	720	910	2000	1039
GPU3-807	800	700	1095	740	70	75	120	90	90	820	910	2000	1101
GPU3-808	800	800	1095	720	70	75	120	100	100	820	1020	2000	1272
GPU3-909	900	900	1195	830	70	75	140	100	100	900	1140	2000	1404
GPU3-1010	1000	1000	1315	920	80	75	150	110	110	1040	1260	2000	1689

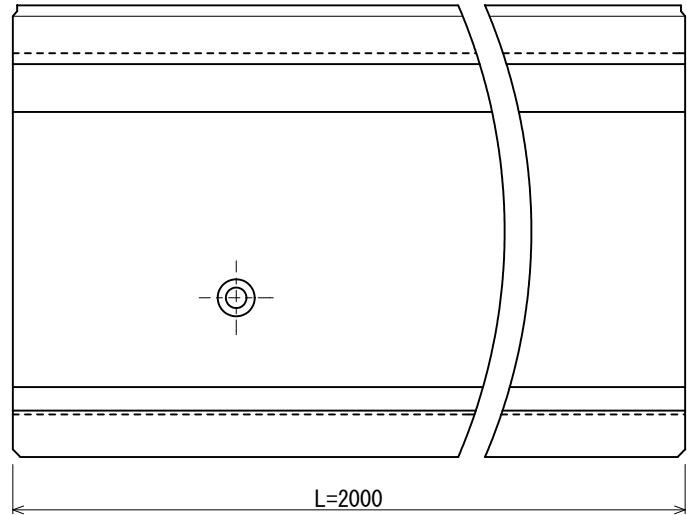
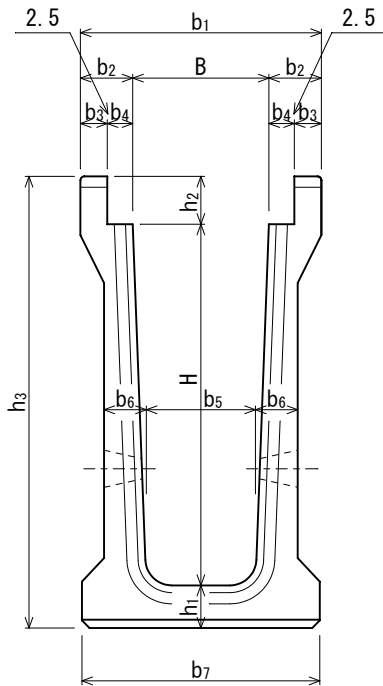

呼び名	寸法 (mm)												参考重量 (kg)
	B	H	b <sub>1</sub>	b <sub>2</sub>	b <sub>3</sub>	b <sub>4</sub>	b <sub>5</sub>	b <sub>6</sub>	b <sub>7</sub>	h <sub>1</sub>	h <sub>2</sub>	h <sub>3</sub>	
GPU $\frac{2}{3}$ -30-60	300	600	535	117.5	60	55	250	80	535	80	100	780	727
GPU $\frac{2}{3}$ -30-70	300	700	535	117.5	60	55	245	85	535	85	100	885	825
GPU $\frac{2}{3}$ -30-80	300	800	535	117.5	60	55	240	90	535	90	100	990	930
GPU $\frac{2}{3}$ -30-90	300	900	535	117.5	60	55	235	95	535	95	100	1095	1043
GPU $\frac{2}{3}$ -30-100	300	1000	535	117.5	60	55	230	100	535	100	100	1200	1163
GPU $\frac{2}{3}$ -40-60	400	600	635	117.5	60	55	350	80	635	80	110	790	770
GPU $\frac{2}{3}$ -40-70	400	700	635	117.5	60	55	345	85	635	85	110	895	872
GPU $\frac{2}{3}$ -40-80	400	800	635	117.5	60	55	340	90	635	90	110	1000	979
GPU $\frac{2}{3}$ -40-90	400	900	635	117.5	60	55	335	95	635	95	110	1105	1095
GPU $\frac{2}{3}$ -40-100	400	1000	635	117.5	60	55	330	100	635	100	110	1210	1217
GPU $\frac{2}{3}$ -50-70	500	700	755	127.5	65	60	445	90	755	90	125	915	997
GPU $\frac{2}{3}$ -50-80	500	800	755	127.5	65	60	440	90	755	90	125	1015	1065
GPU $\frac{2}{3}$ -50-90	500	900	755	127.5	65	60	435	95	755	95	125	1120	1183
GPU $\frac{2}{3}$ -50-100	500	1000	755	127.5	65	60	430	100	755	100	125	1225	1307

\* GPU2とGPU3は鉄筋量を変えて対応できます。

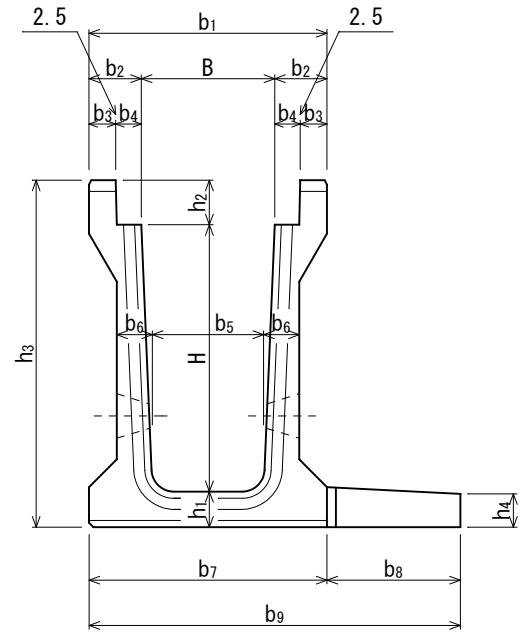
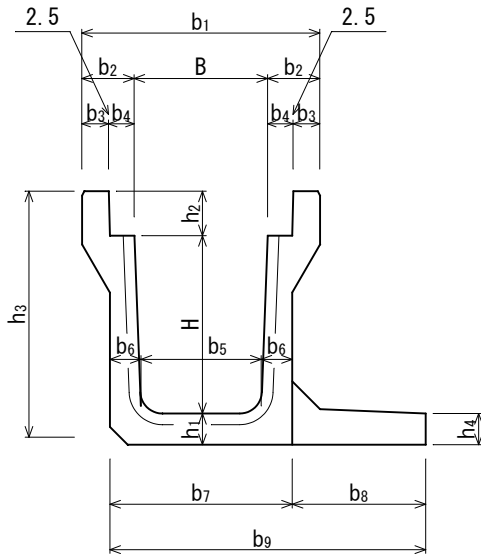

※B300×H300、400、500のみ

呼び名	寸法 (mm)															参考重量 (kg)
	B	H	b <sub>1</sub>	b <sub>2</sub>	b <sub>3</sub>	b <sub>4</sub>	b <sub>5</sub>	b <sub>6</sub>	b <sub>7</sub>	b <sub>8</sub>	b <sub>9</sub>	h <sub>1</sub>	h <sub>2</sub>	h <sub>3</sub>	h <sub>4</sub>	
GPUD $\frac{2}{3}$ -30-30	300	300	535	117.5	60	55	280	70	420	250	670	70	100	470	70	524
GPUD $\frac{2}{3}$ -30-40	300	400	535	117.5	60	55	270	70	410	300	710	70	100	570	70	596
GPUD $\frac{2}{3}$ -30-50	300	500	535	117.5	60	55	260	80	420	350	770	80	100	680	75	738
GPUD $\frac{2}{3}$ -30-60	300	600	535	117.5	60	55	250	80	535	300	835	80	100	780	75	845
GPUD $\frac{2}{3}$ -30-70	300	700	535	117.5	60	55	245	85	535	350	885	85	100	885	76	967
GPUD $\frac{2}{3}$ -30-80	300	800	535	117.5	60	55	240	90	535	400	935	90	100	990	76	1099
GPUD $\frac{2}{3}$ -30-90	300	900	535	117.5	60	55	235	95	535	450	985	95	100	1095	76	1237
GPUD $\frac{2}{3}$ -30-100	300	1000	535	117.5	60	55	230	100	535	450	985	100	100	1200	80	1368
GPUD $\frac{2}{3}$ -40-60	400	600	635	117.5	60	55	350	80	635	300	935	80	110	790	75	889
GPUD $\frac{2}{3}$ -40-70	400	700	635	117.5	60	55	345	85	635	350	985	85	110	895	76	1014
GPUD $\frac{2}{3}$ -40-80	400	800	635	117.5	60	55	340	90	635	400	1035	90	110	1000	76	1148
GPUD $\frac{2}{3}$ -40-90	400	900	635	117.5	60	55	335	95	635	450	1085	95	110	1105	76	1289
GPUD $\frac{2}{3}$ -40-100	400	1000	635	117.5	60	55	330	100	635	450	1085	100	110	1210	80	1422
GPUD $\frac{2}{3}$ -50-70	500	700	755	127.5	65	60	445	90	755	350	1105	90	125	915	76	1145
GPUD $\frac{2}{3}$ -50-80	500	800	755	127.5	65	60	440	90	755	400	1155	90	125	1015	76	1234
GPUD $\frac{2}{3}$ -50-90	500	900	755	127.5	65	60	435	95	755	450	1205	95	125	1120	76	1377
GPUD $\frac{2}{3}$ -50-100	500	1000	755	127.5	65	60	430	100	755	450	1205	100	125	1225	80	1512

\* 製品長はL=2000mmになります。

\* GPUD2とGPUD3は鉄筋量を変えて対応できます。



## PC3 (歩道用)

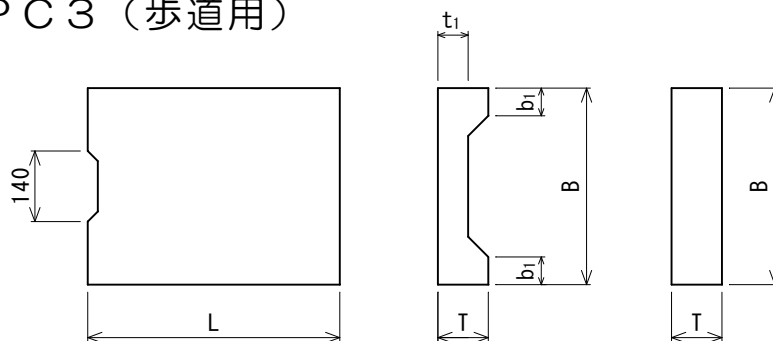

JIS A 5372 1種参考

呼び名	寸法 (mm)					参考重量 (kg)
	B	b <sub>1</sub>	T	t <sub>1</sub>	L	
PC3-B 250	350	55	90	55	500	29
PC3-B 300	400	55	100	60	500	36
PC3-B 400	500	55	110	65	500	47
PC3-B 500	610	60	125	75	500	65
PC3-B 450	540	—	110	—	500	71
PC3-B 600	710	—	130	—	500	111
PC3-B 700	810	—	120	—	1000	233
PC3-B 800	930	—	120	—	1000	268
PC3-B 900	1030	—	140	—	1000	346
PC3-B1000	1150	—	150	—	1000	414

## PC4 (車道用)

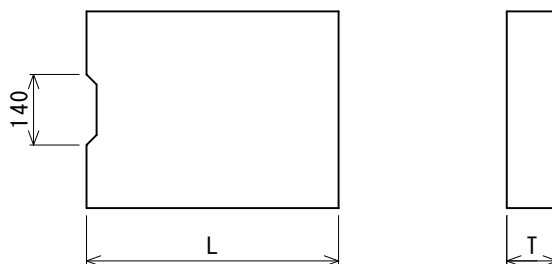

JIS A 5372 3種参考

呼び名	寸法 (mm)			参考重量 (kg)
	B	T	L	
PC4-B 250	350	90	500	37
PC4-B 300	400	100	500	47
PC4-B 400	500	110	500	65
PC4-B 450	540	110	500	71
PC4-B 500	610	125	500	91
PC4-B 600	710	130	500	111
PC4-B 700	810	120	1000	233
PC4-B 800	930	120	1000	268
PC4-B 900	1030	140	1000	346
PC4-B1000	1150	150	1000	414

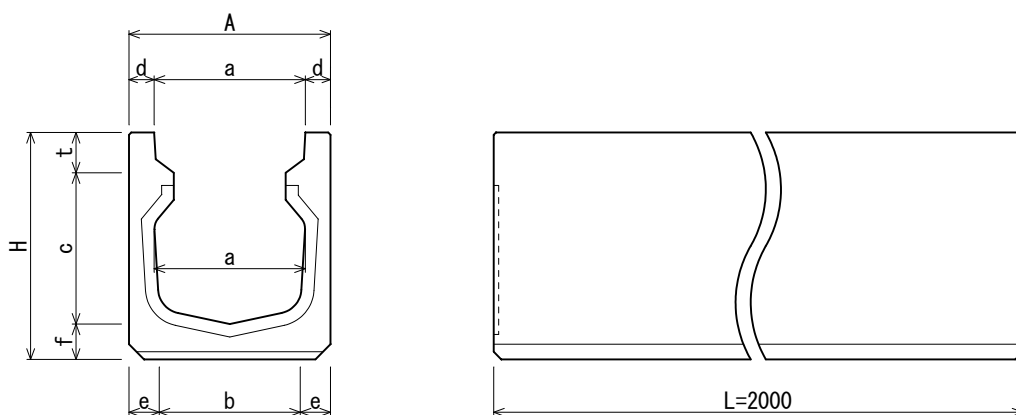

呼び名	寸法 (mm)									参考重量 (kg)
	A	a	b	c	d	e	f	t	H	
HB-PU-250	350	250	230	250	50	60	65	80	395	318
HB-PU-303	400	300	280	300	50	60	70	80	450	385
HB-PU-304			270	400		65	75		555	455
HB-PU-305			260	500		70	80		660	529
HB-PU-306			250	600		75	80		760	599
HB-PU-404	500	400	370	400	50	65	75	100	575	506
HB-PU-405			360	500		70	80		680	583
HB-PU-406			350	600		75	85		785	665

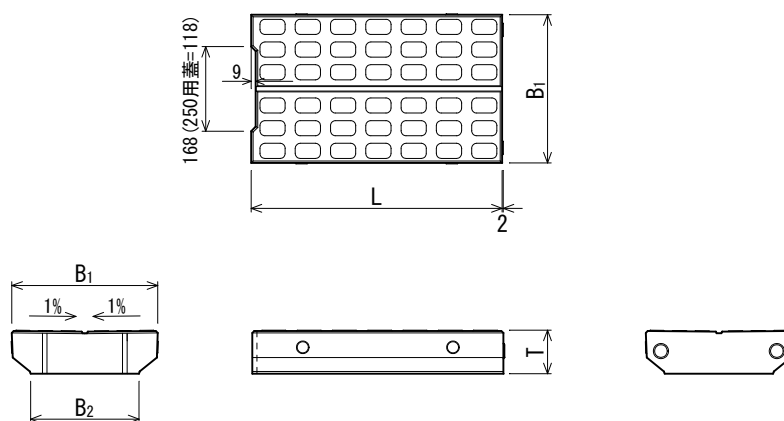

呼び名	寸法 (mm)				参考重量 (kg)
	B <sub>1</sub>	B <sub>2</sub>	L	T	
250用蓋	240	156	498	85	23
300用蓋	290	206	498	85	28
400用蓋	390	306	498	105	46

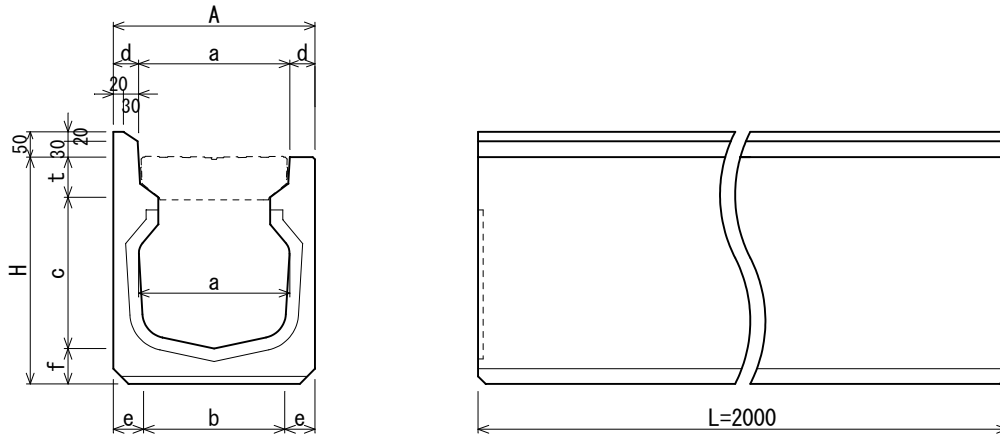

呼び名	寸法 (mm)									参考重量 (kg)
	A	a	b	c	d	e	f	t	H	
MHB-PU-303	400	300	280	300	50	60	70	80	450	398

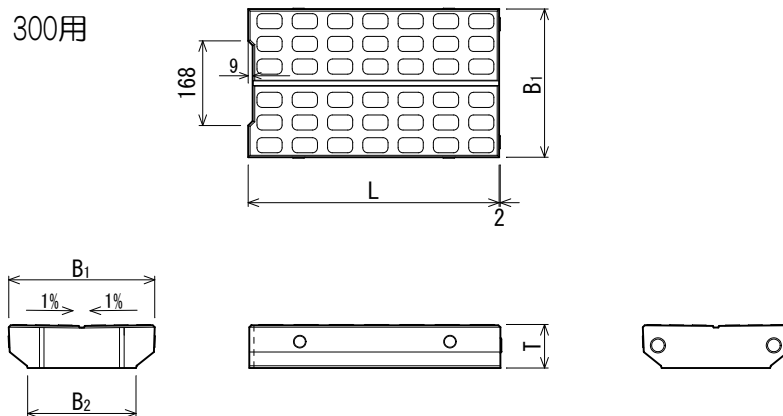

呼び名	寸法 (mm)				参考重量 (kg)
	B <sub>1</sub>	B <sub>2</sub>	L	T	
300用蓋	290	206	498	85	28



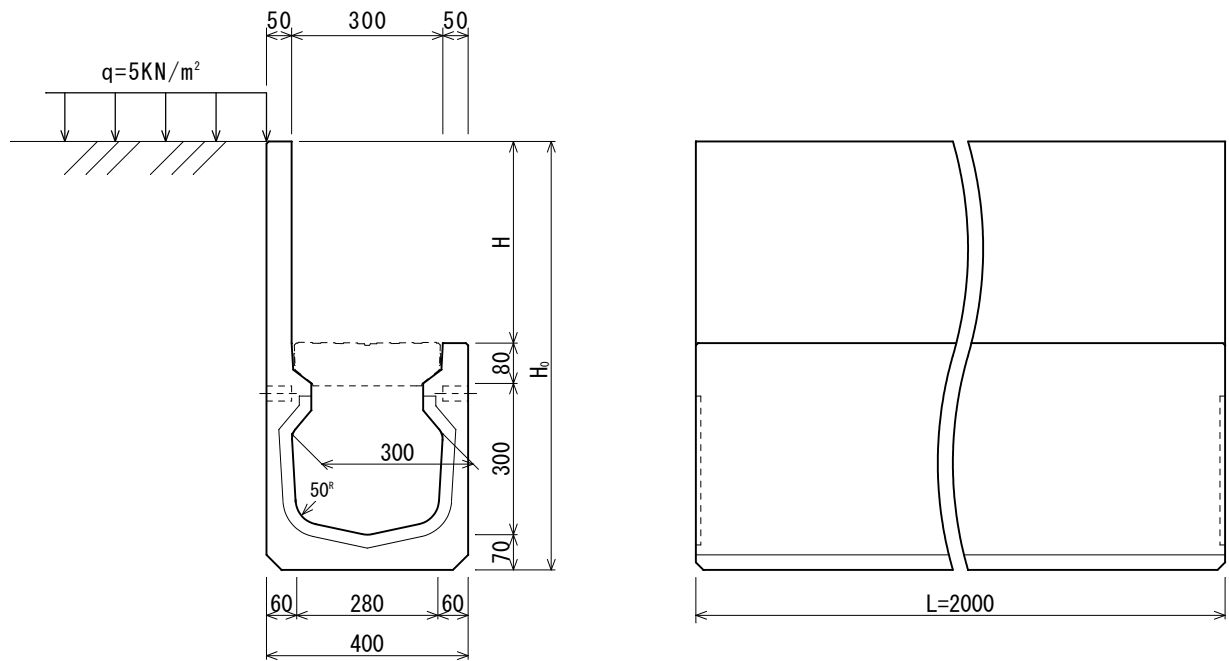

呼び名	寸法 (mm)		参考重量 (kg)
	H	H <sub>0</sub>	
HB-PU-303-H100	100	550	410
HB-PU-303-H200	200	650	434
HB-PU-303-H300	300	750	458
HB-PU-303-H400	400	850	482
HB-PU-303-H500	500	950	506

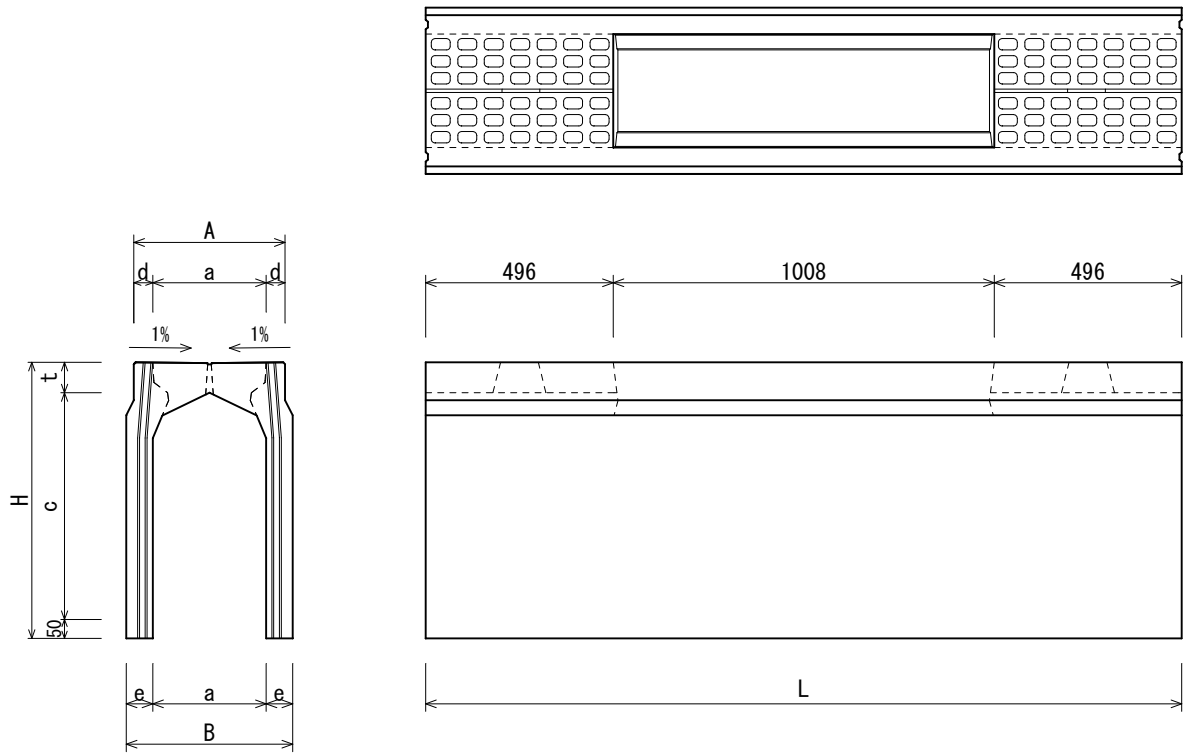

呼び名	寸法 (mm)									参考重量 (kg)					
	a	c	d	e	t	A	B	H	L						
HB-FS 300 × 300	300	300	50	55	80	400	410	430	2000	323					
HB-FS 300 × 400		400						530		376					
HB-FS 300 × 500		500						630		429					
HB-FS 300 × 600		600						730		571					
HB-FS 300 × 700		700						830		638					
HB-FS 300 × 800		800		930			705								
HB-FS 300 × 900		900		1030			986								
HB-FS 300 × 1000		1000		1130			1077								
HB-FS 300 × 1100		1100		1230			1168								
HB-FS 300 × 1200		1200		1330			1259								
HB-FS 300 × 1300		1300		1430			1350								
HB-FS 300 × 1400		1400		1530			1442								
HB-FS 300 × 1500		1500		1630			1533								
HB-FS 400 × 400		400		400			50	60		100	500	520	550	2000	456
HB-FS 400 × 500				500									650		514
HB-FS 400 × 600	600		750	571											
HB-FS 400 × 700	700		850	732											
HB-FS 400 × 800	800		950	804											
HB-FS 400 × 900	900		1050	876											
HB-FS 400 × 1000	1000		1150	1136											
HB-FS 400 × 1100	1100		1250	1227											
HB-FS 400 × 1200	1200		1350	1318											
HB-FS 400 × 1300	1300		1450	1410											
HB-FS 400 × 1400	1400		1550	1501											
HB-FS 400 × 1500	1500		1650	1592											

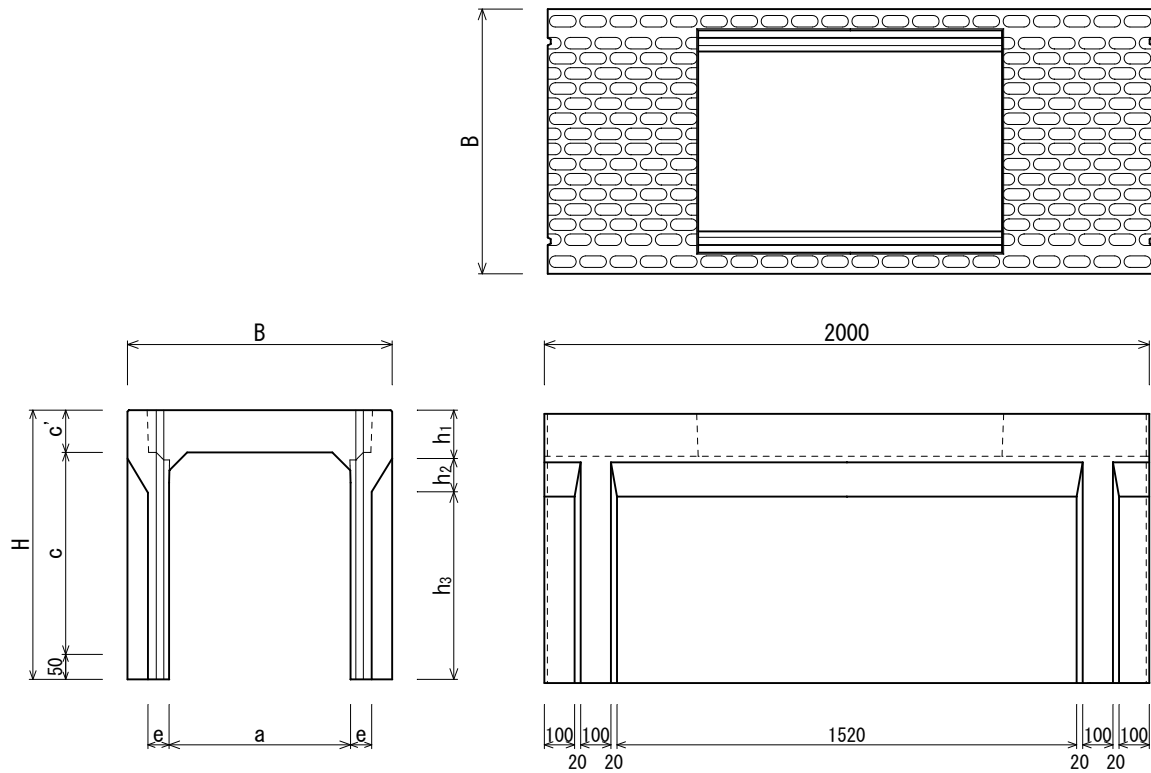

呼び名	寸法 (mm)									参考重量 (kg)				
	B	H	a	c	c'	e	h <sub>1</sub>	h <sub>2</sub>	h <sub>3</sub>					
HB-FS 600 × 400	875	590	600	400	140	60	160	130	300	735				
HB-FS 600 × 500		690		500					400	801				
HB-FS 600 × 600		790		600					500	868				
HB-FS 600 × 700		890		700					600	985				
HB-FS 600 × 800		990		800		700		1060						
HB-FS 600 × 900		1090		900		800		1135						
HB-FS 600 × 1000		1190		1000		900		1210						
HB-FS 600 × 1100		1290		1100		1000		1285						
HB-FS 600 × 1200		1390		1200		1100		1360						
HB-FS 600 × 1300		1490		1300		1200		1435						
HB-FS 600 × 1400		1590		1400		1300		1510						
HB-FS 600 × 1500		1690		1500		1400		1585						
HB-FS 700 × 600		970		800		700		600	150	85	170	100	530	1011
HB-FS 700 × 700				900				700					600	1099
HB-FS 700 × 800	1000		800	700	1186									
HB-FS 700 × 900	1100		900	800	1273									
HB-FS 700 × 1000	1200		1000	900	1360									
HB-FS 700 × 1100	1300		1100	1000	1448									
HB-FS 700 × 1200	1400		1200	1100	1535									
HB-FS 700 × 1300	1500		1300	1200	1622									
HB-FS 700 × 1400	1600		1400	1300	1710									
HB-FS 700 × 1500	1700		1500	1400	1797									
HB-FS 700 × 1600	1800		1600	1500	1885									
HB-FS 700 × 1700	1900		1700	1600	1972									
HB-FS 700 × 1700				1700	150		100	70		1660		2181		

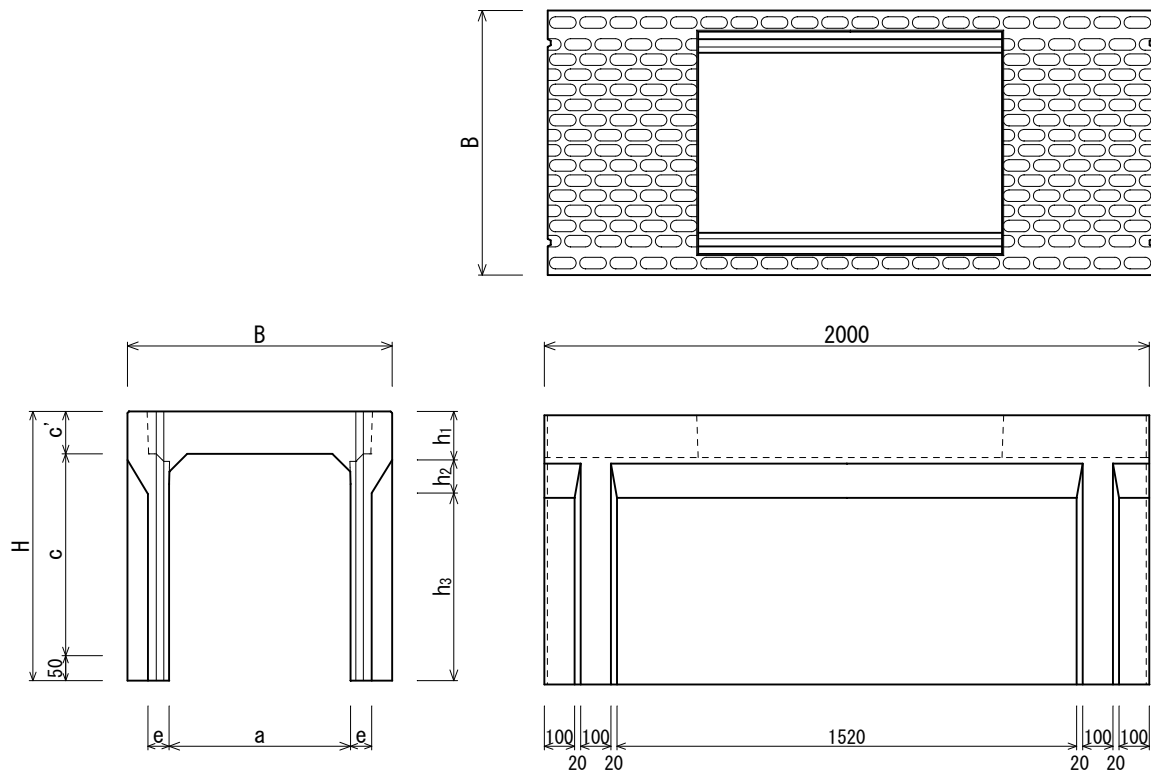

呼び名	寸法 (mm)									参考重量 (kg)
	B	H	a	c	c'	e	h <sub>1</sub>	h <sub>2</sub>	h <sub>3</sub>	
HB-FS 800×600	1060	810	800	600	160	90	180	80	550	1094
HB-FS 800×700		910							650	1185
HB-FS 800×800		1010							750	1278
HB-FS 800×900		1110							850	1367
HB-FS 800×1000		1210							950	1458
HB-FS 800×1100		1310							1050	1549
HB-FS 800×1200		1410							1150	1640
HB-FS 800×1300		1510							1250	1731
HB-FS 800×1400		1610							1350	1822
HB-FS 800×1500		1710							1450	1913
HB-FS 800×1600		1810							1550	2004
HB-FS 900×700	1170	920	900	700	170	90	190	80	650	1270
HB-FS 900×800		1020							750	1361
HB-FS 900×900		1120							850	1453
HB-FS 900×1000		1220							950	1545
HB-FS 900×1100		1320							1050	1638
HB-FS 900×1200		1420							1150	1728
HB-FS 900×1300		1520							1250	1819
HB-FS 900×1400		1620							1350	1911
HB-FS 900×1500		1720							1450	2002
HB-FS 1000×800		1300							1030	1000
HB-FS 1000×900	1130		830	1566						
HB-FS 1000×1000	1230		930	1658						
HB-FS 1000×1100	1330		1030	1751						
HB-FS 1000×1200	1430		1130	1844						
HB-FS 1000×1300	1530		1250	2041						
HB-FS 1000×1400	1630		1350	2142						
HB-FS 1000×1500	1730		1450	2243						
HB-FS 1000×1600	1830		1550	2347						

# HB-F S側溝用蓋

300・400用

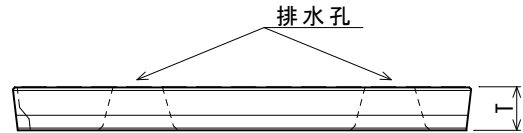
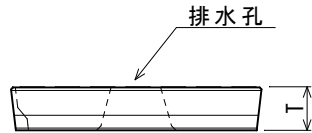
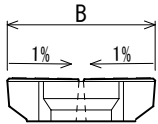
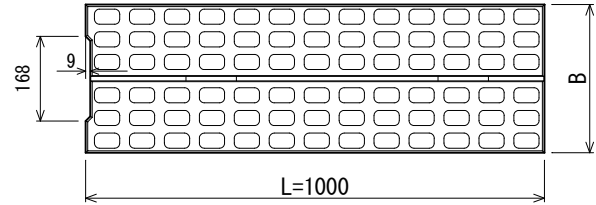
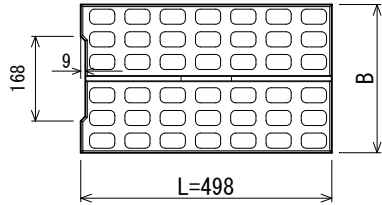

呼び名	寸法(mm)			参考重量 (kg)	寸法(mm)		参考重量 (kg)
	B	T	L		L		
300用蓋	294	85	498	27	1000		54
400用蓋	394	105	498	45	1000		94

600~1000用

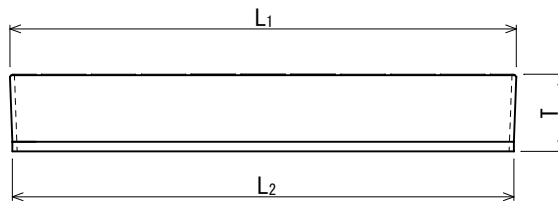
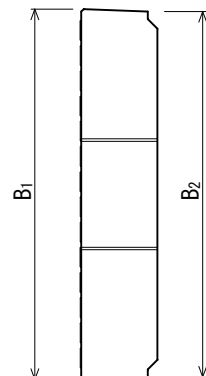
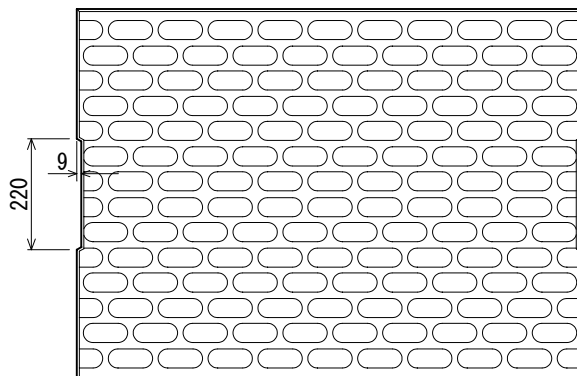

呼び名	寸法(mm)					参考重量 (kg)
	B <sub>1</sub>	B <sub>2</sub>	L <sub>1</sub>	L <sub>2</sub>	T	
600用蓋	735	725	1005	995	153	261
700用蓋	820	800	1000	980	163	310
800用蓋	900	880	1000	980	172	361
900用蓋	1010	990	1000	980	183	431
1000用蓋	1130	1110	1000	980	193	509

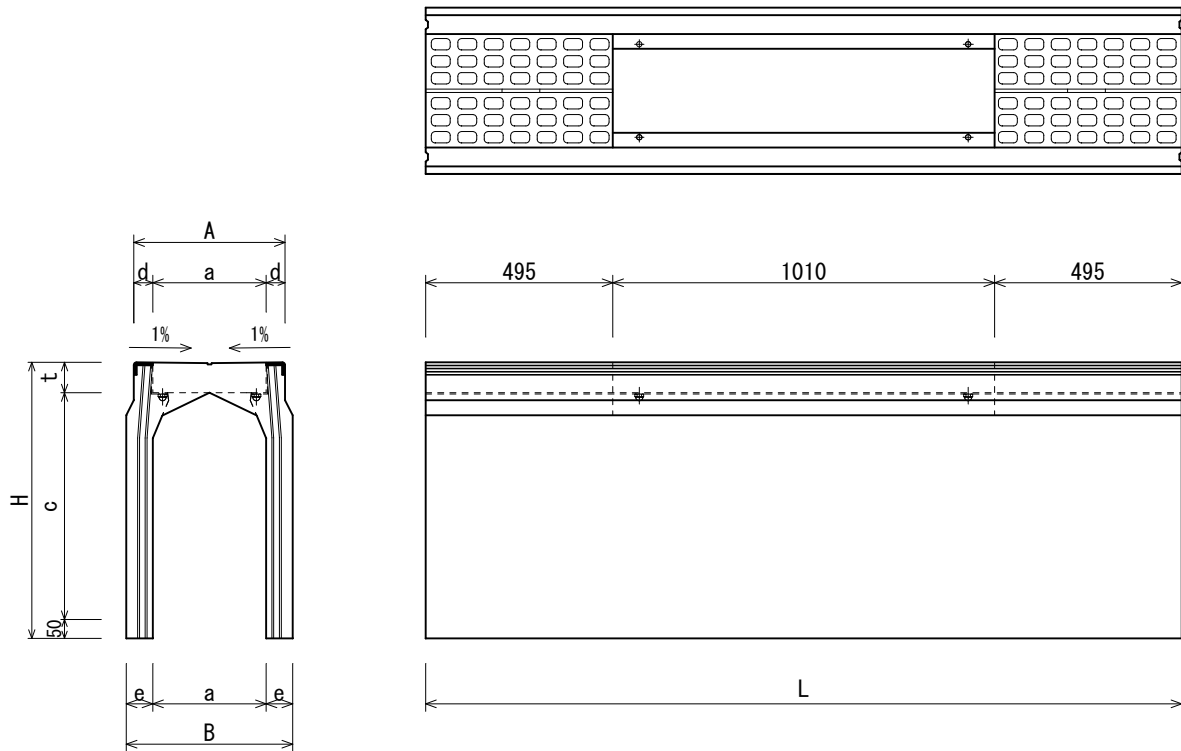

呼び名	寸法 (mm)									参考重量 (kg)						
	a	c	d	e	t	A	B	H	L							
HB-FSG 300 × 300	300	300	50	55	80	400	410	430	2000	323						
HB-FSG 300 × 400		400						530		376						
HB-FSG 300 × 500		500						630		429						
HB-FSG 300 × 600		600						730		571						
HB-FSG 300 × 700		700						830		638						
HB-FSG 300 × 800		800						930		705						
HB-FSG 300 × 900		900	1030	95	100	500	490	1030		986						
HB-FSG 300 × 1000		1000	1130					1077								
HB-FSG 300 × 1100		1100	1230					1168								
HB-FSG 300 × 1200		1200	1330	95	100	500	590	1330		1259						
HB-FSG 300 × 1300		1300	1430					1350								
HB-FSG 300 × 1400		1400	1530					1442								
HB-FSG 300 × 1500		1500	1630					1533								
HB-FSG 400 × 400		400	400					50		60	100	500	520	550	2000	456
HB-FSG 400 × 500			500											650		514
HB-FSG 400 × 600	600		750	571												
HB-FSG 400 × 700	700		850	732												
HB-FSG 400 × 800	800		950	804												
HB-FSG 400 × 900	900		1050	876												
HB-FSG 400 × 1000	1000		1150	95	100	500	590	1150	1136							
HB-FSG 400 × 1100	1100		1250					1227								
HB-FSG 400 × 1200	1200		1350					1318								
HB-FSG 400 × 1300	1300		1450	95	100	500	590	1450	1410							
HB-FSG 400 × 1400	1400		1550					1501								
HB-FSG 400 × 1500	1500		1650					1592								

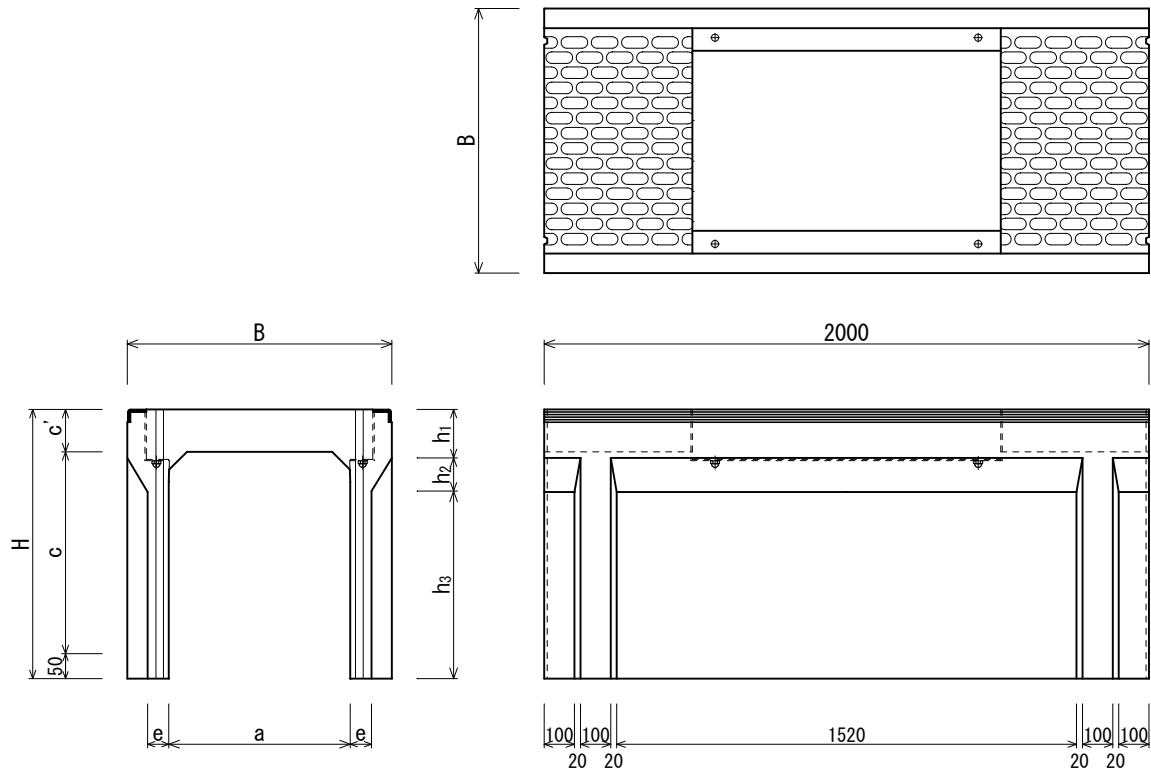

呼び名	寸 法 (mm)									参考重量 (kg)				
	B	H	a	c	c'	e	h <sub>1</sub>	h <sub>2</sub>	h <sub>3</sub>					
HB-FSG 600 × 400	875	590	600	400	140	60	160	130	300	735				
HB-FSG 600 × 500		690		500					400	801				
HB-FSG 600 × 600		790		600					500	868				
HB-FSG 600 × 700		890		700					620	985				
HB-FSG 600 × 800		990		800		70		720	1060					
HB-FSG 600 × 900		1090		900		110		820	1135					
HB-FSG 600 × 1000		1190		1000				950	1326					
HB-FSG 600 × 1100		1290		1100		80		1050	1414					
HB-FSG 600 × 1200		1390		1200				1150	1502					
HB-FSG 600 × 1300		1490		1300		60		1270	1695					
HB-FSG 600 × 1400		1590		1400				1370	1791					
HB-FSG 600 × 1500		1690		1500		1470		1887						
HB-FSG 700 × 600		970		800		700		600	150	85	170	100	530	1011
HB-FSG 700 × 700				900				700					630	1099
HB-FSG 700 × 800	1000		800	730	1186									
HB-FSG 700 × 900	1100		900	830	1273									
HB-FSG 700 × 1000	1200		1000	930	1361									
HB-FSG 700 × 1100	1300		1100	1030	1448									
HB-FSG 700 × 1200	1400		1200	70	1160		1681							
HB-FSG 700 × 1300	1500		1300		1260		1781							
HB-FSG 700 × 1400	1600		1400		100		1360	1881						
HB-FSG 700 × 1500	1700		1500		1460		1981							
HB-FSG 700 × 1600	1800		1600		1560		2081							
HB-FSG 700 × 1700	1900		1700		1660		2181							

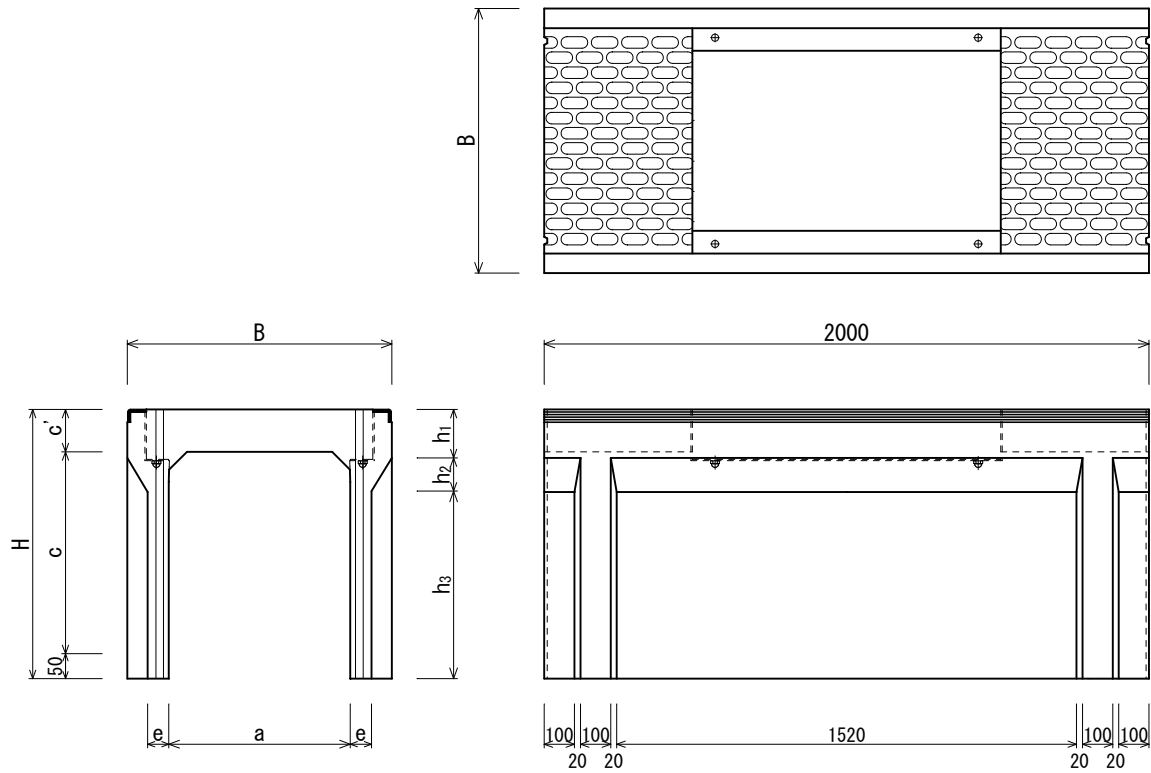

呼び名	寸 法 (mm)									参考重量 (kg)
	B	H	a	c	c'	e	h <sub>1</sub>	h <sub>2</sub>	h <sub>3</sub>	
HB-FSG 800 × 600	1060	810	800	600	160	90	180	80	550	1094
HB-FSG 800 × 700		910		700					650	1185
HB-FSG 800 × 800		1010		800					750	1278
HB-FSG 800 × 900		1110		900					850	1367
HB-FSG 800 × 1000		1210		1000					950	1458
HB-FSG 800 × 1100		1310		1100					1050	1549
HB-FSG 800 × 1200		1410		1200					1150	1640
HB-FSG 800 × 1300		1510		1300					1250	1731
HB-FSG 800 × 1400		1610		1400					1350	1822
HB-FSG 800 × 1500		1710		1500					1450	1913
HB-FSG 800 × 1600		1810		1600					1550	2004
HB-FSG 900 × 700	1170	920	900	700	170	90	190	80	650	1270
HB-FSG 900 × 800		1020		800					750	1361
HB-FSG 900 × 900		1120		900					850	1453
HB-FSG 900 × 1000		1220		1000					950	1545
HB-FSG 900 × 1100		1320		1100					1050	1638
HB-FSG 900 × 1200		1420		1200					1150	1728
HB-FSG 900 × 1300		1520		1300					1250	1819
HB-FSG 900 × 1400		1620		1400					1350	1911
HB-FSG 900 × 1500		1720		1500					1450	2002
HB-FSG 1000 × 800	1300	1030	1000	800	180	90	200	100	730	1476
HB-FSG 1000 × 900		1130		900					830	1566
HB-FSG 1000 × 1000		1230		1000					930	1658
HB-FSG 1000 × 1100		1330		1100					1030	1751
HB-FSG 1000 × 1200		1430		1200					1130	1844
HB-FSG 1000 × 1300		1530		1300		1250		2041		
HB-FSG 1000 × 1400		1630		1400		1350		2142		
HB-FSG 1000 × 1500		1730		1500		1450		2243		
HB-FSG 1000 × 1600		1830		1600		1550		2347		



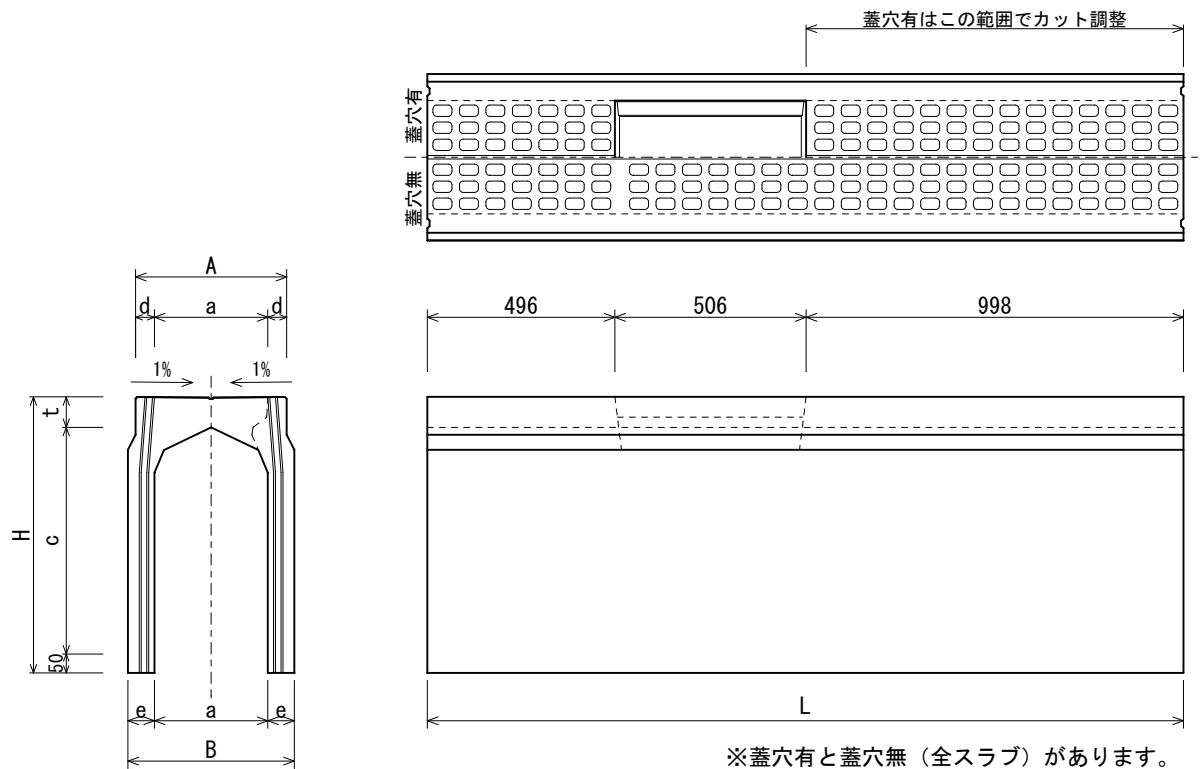

呼び名	寸法 (mm)									参考重量 (kg)			
	a	c	d	e	t	A	B	H	L	蓋穴有	蓋穴無		
HB-FS 303 (調整用)	300	300	50	70	80	400	440	430	2000	398	432		
HB-FS 304 (調整用)		400						465		499			
HB-FS 305 (調整用)		500						532		566			
HB-FS 306 (調整用)		600						599		633			
HB-FS 307 (調整用)		700						666		700			
HB-FS 308 (調整用)		800						733		767			
HB-FS 309 (調整用)		900						1008		1042			
HB-FS 3010 (調整用)		1000	1099	1133									
HB-FS 3011 (調整用)		1100	1190	1224									
HB-FS 3012 (調整用)		1200	1281	1315									
HB-FS 3013 (調整用)		1300	1372	1406									
HB-FS 3014 (調整用)		1400	1463	1497									
HB-FS 3015 (調整用)		1500	1554	1588									
HB-FS 404 (調整用)		400	400	50	75	100	500	550		550	2000	564	614
HB-FS 405 (調整用)			500							636		686	
HB-FS 406 (調整用)	600		708						758				
HB-FS 407 (調整用)	700		780						830				
HB-FS 408 (調整用)	800		852						902				
HB-FS 409 (調整用)	900		924						974				
HB-FS 4010 (調整用)	1000		1185						1235				
HB-FS 4011 (調整用)	1100		1276	1326									
HB-FS 4012 (調整用)	1200		1367	1417									
HB-FS 4013 (調整用)	1300		1458	1508									
HB-FS 4014 (調整用)	1400		1549	1599									
HB-FS 4015 (調整用)	1500		1640	1690									

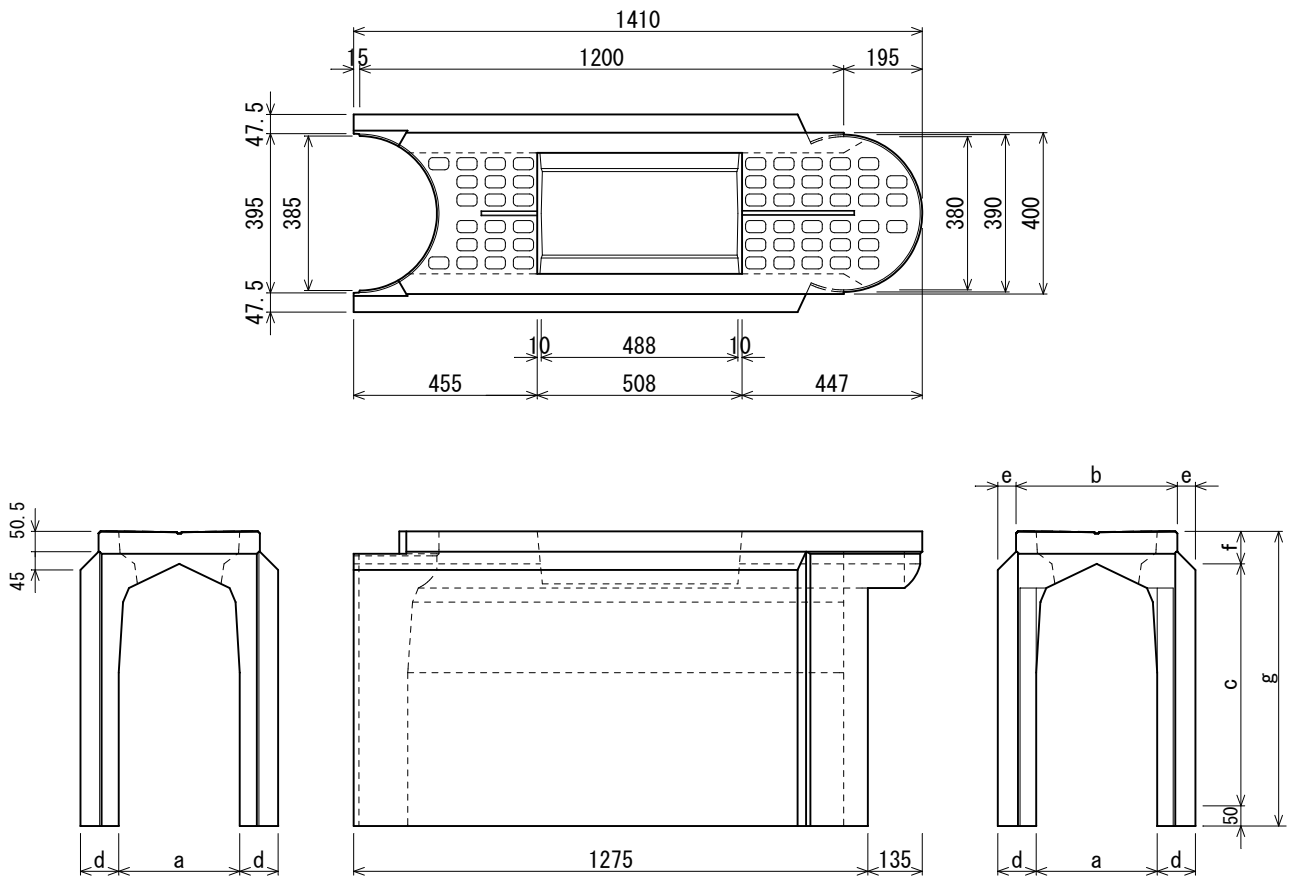

呼び名	寸法(mm)							参考重量 (kg)
	a	b	c	d	e	f	g	
HB-FS-303 フレキシブル	300	400	300	95	45	80	430	279
HB-FS-304 フレキシブル			400				530	331
HB-FS-305 フレキシブル			500				630	383
HB-FS-306 フレキシブル			600				730	434
HB-FS-307 フレキシブル			700				830	486
HB-FS-308 フレキシブル			800				930	538
HB-FS-309 フレキシブル			900				1030	590
HB-FS-3010 フレキシブル			1000				1130	642
HB-FS-3011 フレキシブル			1100				1230	694
HB-FS-3012 フレキシブル			1200				1330	746

(メス部)

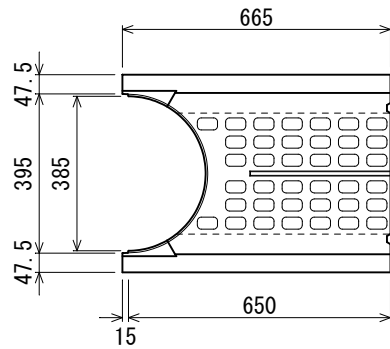

(オス部)

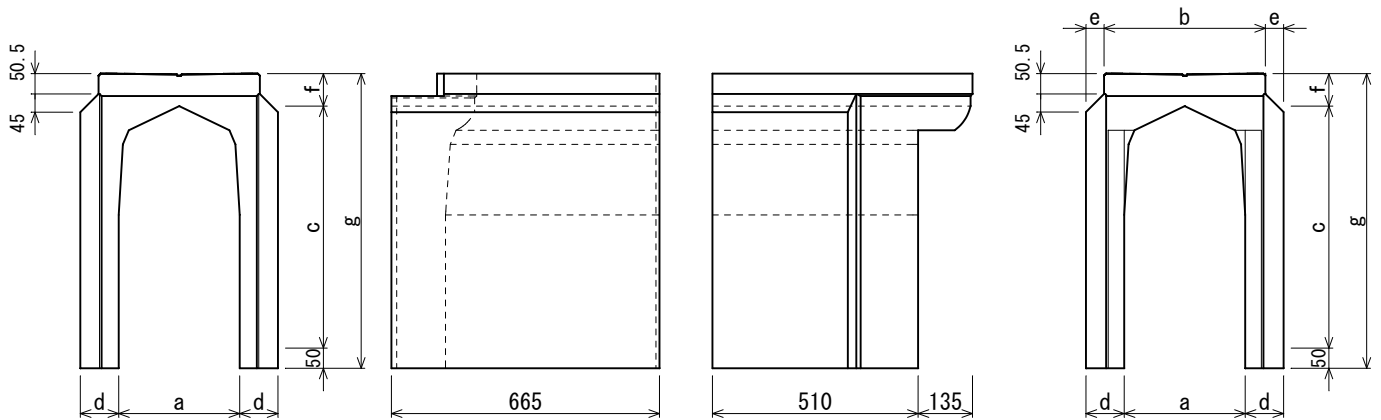
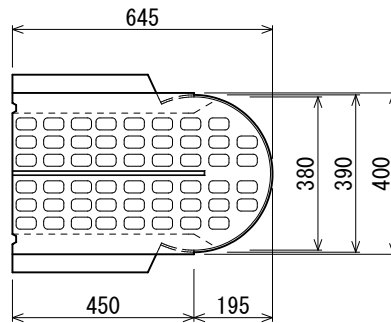

呼び名	寸法 (mm)							参考重量 (kg)	
	a	b	c	d	e	f	g	オス部	メス部
HB-FS-303 フレキシブル	300	400	300	95	45	80	430	128	157
HB-FS-304 フレキシブル			400				530	146	186
HB-FS-305 フレキシブル			500				630	165	215
HB-FS-306 フレキシブル			600				730	183	244
HB-FS-307 フレキシブル			700				830	202	272
HB-FS-308 フレキシブル			800				930	221	301
HB-FS-309 フレキシブル			900				1030	239	330
HB-FS-3010 フレキシブル			1000				1130	258	356
HB-FS-3011 フレキシブル			1100				1230	276	388
HB-FS-3012 フレキシブル			1200				1330	295	416

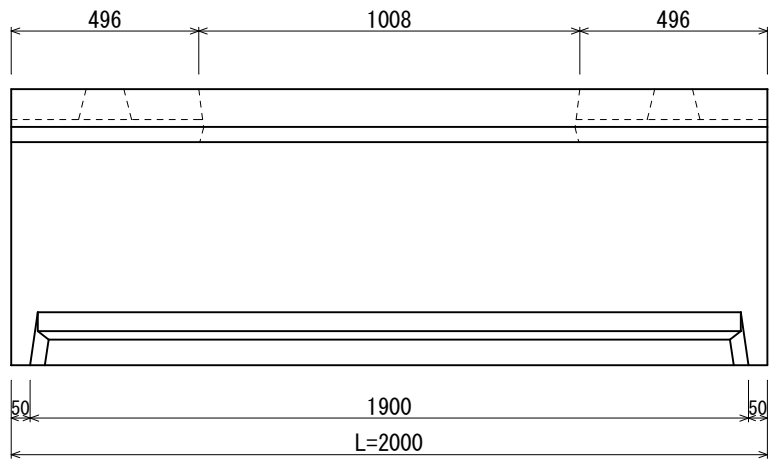
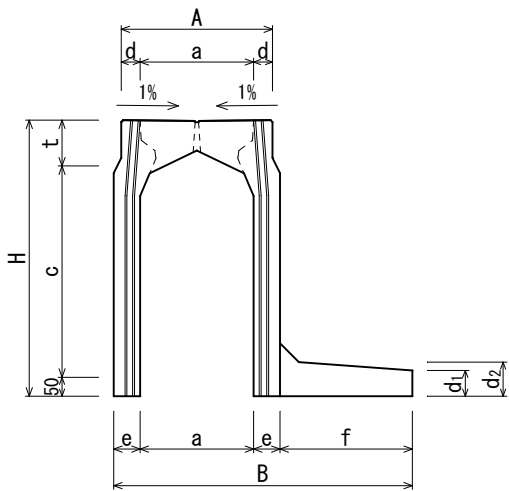
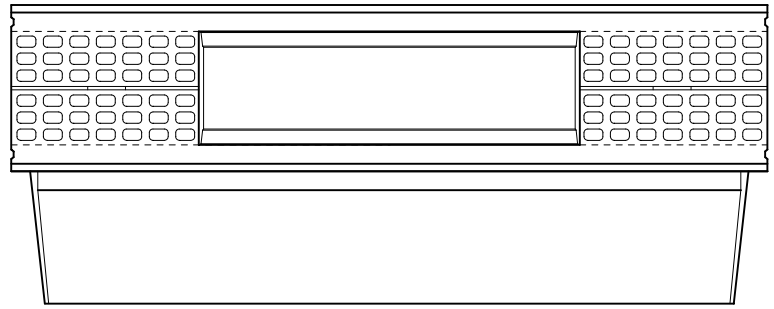

呼び名	寸法 (mm)											参考重量 (kg)																		
	a	c	d	e	t	A	B	H	f	d <sub>1</sub>	d <sub>2</sub>																			
HB-FS 303(土)	300	300	50	55	80	400	710	430	300	60	80	425																		
HB-FS 304(土)		400						530					80	478																
HB-FS 305(土)		500						630							531															
HB-FS 306(土)		600		730				60	688																					
HB-FS 307(土)		700		830				70					836																	
HB-FS 308(土)		800		930				50								903														
HB-FS 309(土)		900		1030				70									1176													
HB-FS 3010(土)		1000		1130				100										1267												
HB-FS 3011(土)		1100		1230				80											1408											
HB-FS 3012(土)		1200		1330				110												1520										
HB-FS 404(土)		400		400				50													60	100	500	870	550	350	60	80	573	
HB-FS 405(土)				500																					650					80
HB-FS 406(土)	600		750	688																										
HB-FS 407(土)	700		850		70	930																								
HB-FS 408(土)	800		950		75		1002																							
HB-FS 409(土)	900		1050		100				1074																					
HB-FS 4010(土)	1000		1090		80					1362																				
HB-FS 4011(土)	1100		1140		110						1475																			
HB-FS 4012(土)	1200		1190		95							1587																		
HB-FS 4013(土)	1300		1240		80								1700																	
HB-FS 4014(土)	1400		1290		110									1812																

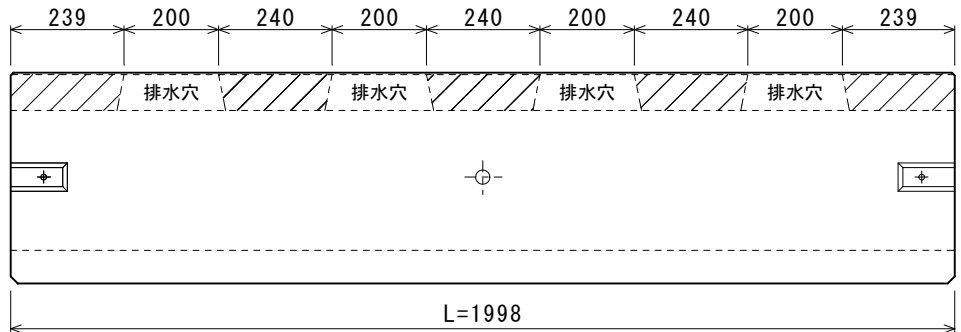
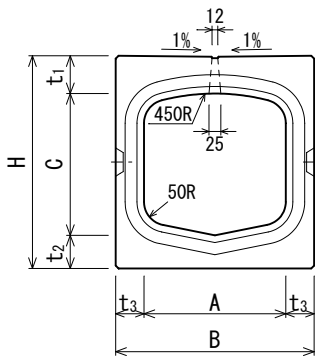
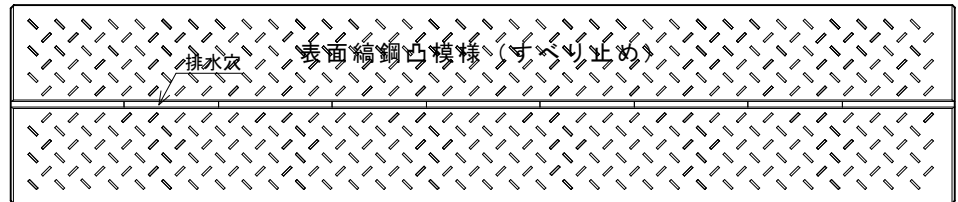

呼び名 A × C	寸 法 (mm)							参考重量 (kg)
	A	B	C	t <sub>1</sub>	t <sub>2</sub>	t <sub>3</sub>	H	
250 × 250	250	370	250	80	65	60	395	434
300 × 300	300	420	300	80	70	60	450	523
300 × 400	300	420	400	80	75	60	555	591
300 × 500	300	420	500	80	80	60	660	659

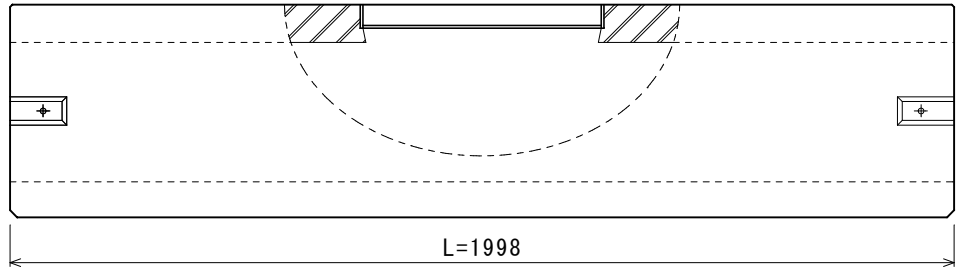
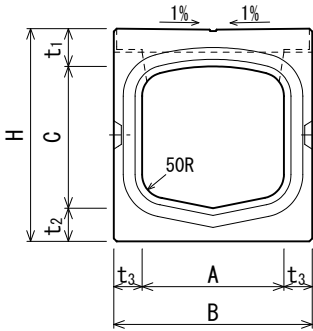
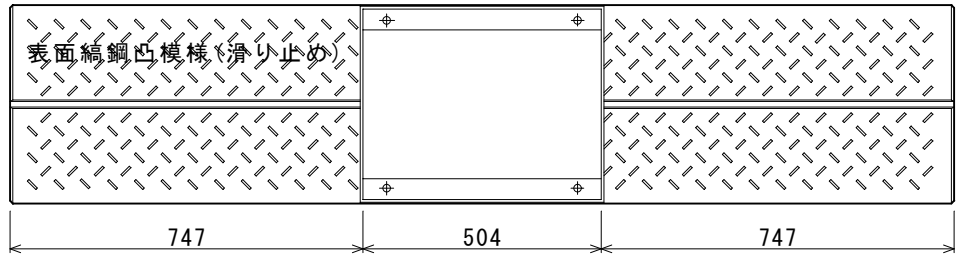

呼び名 A×C	寸 法 (mm)							参考重量 (kg)
	A	B	C	t <sub>1</sub>	t <sub>2</sub>	t <sub>3</sub>	H	
300×300	300	420	300	80	70	60	450	482
300×400	300	420	400	80	75	60	555	550
300×500	300	420	500	80	80	60	660	618

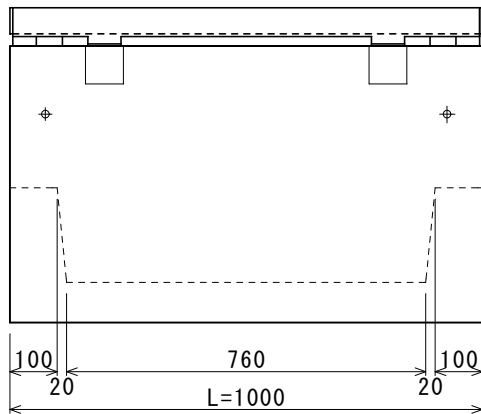
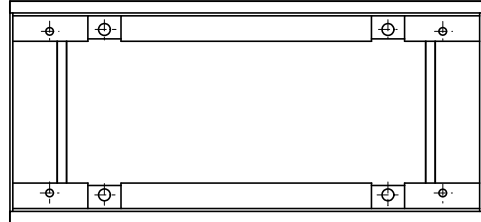
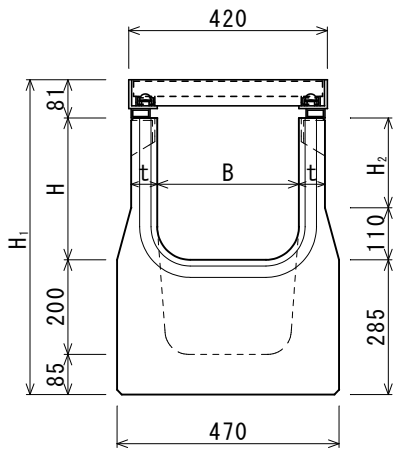

呼び名 B × H	寸法 (mm)					参考重量 (kg)
	B	H	H <sub>1</sub>	H <sub>2</sub>	t	
300 × 300	300	300	666	190	55	326
300 × 400	300	400	766	290	55	353
300 × 500	300	500	866	390	55	381

# 横断用側溝(グレーチング: ボルト固定式) GLU(T-25)

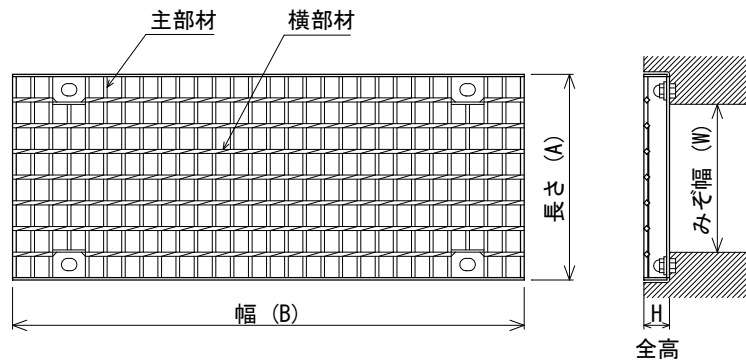
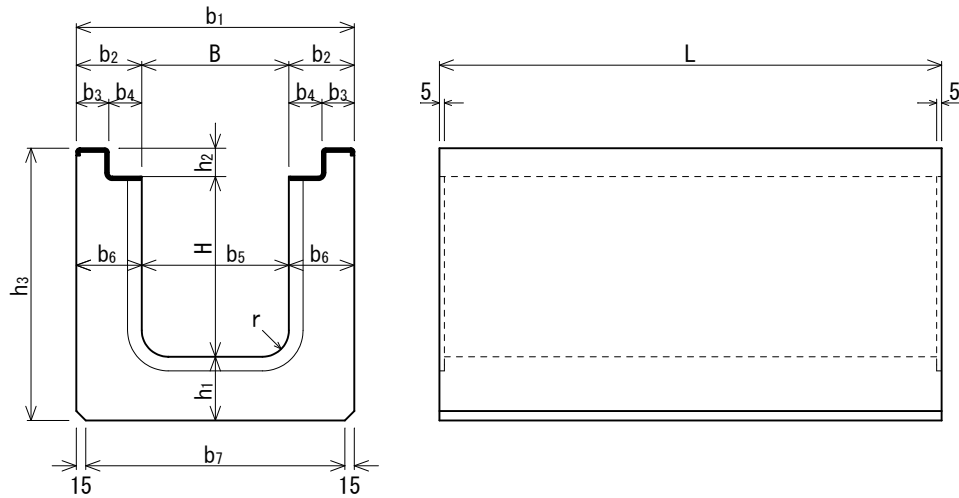

呼び名	寸法 (mm)			参考重量 (kg)
	A	B	H	
溝幅-250用	350	995	50	24
溝幅-300用	400	995	50	27
溝幅-400用	500	995	65	43
溝幅-450用	550	995	65	53
溝幅-500用	600	995	75	58
溝幅-600用	700	995	90	81

呼び名	寸法 (mm)												参考重量 (kg)	
	B	H	b <sub>1</sub>	b <sub>2</sub>	b <sub>3</sub>	b <sub>4</sub>	b <sub>5</sub>	b <sub>6</sub>	b <sub>7</sub>	h <sub>1</sub>	h <sub>2</sub>	h <sub>3</sub>		L
GLU-250	250	290	490	120	65	55	230	130	460	100	50	440	2000	666
GLU-303	300	350	540	120	65	55	280	130	510	120	50	520	2000	767
GLU-304	300	450	540	120	65	55	280	130	510	120	50	620	2000	887
GLU-305	300	550	540	120	65	55	280	130	510	120	50	720	2000	1007
GLU-404	400	445	640	120	65	55	380	130	610	120	65	630	2000	948
GLU-405	400	545	640	120	65	55	380	130	610	120	65	730	2000	1068
GLU-450	450	495	690	120	65	55	430	130	660	120	65	680	2000	1031
GLU-505	505	550	760	127.5	75	52.5	460	150	730	130	75	755	2000	1289
GLU-506	505	650	760	127.5	75	52.5	460	150	730	130	75	855	2000	1432
GLU-606	600	640	860	130	75	55	560	150	830	130	90	860	2000	1467

備考) L=1mも製作しています。



# 横断用グレーチング側溝 深溝型



# GLU(T-25)

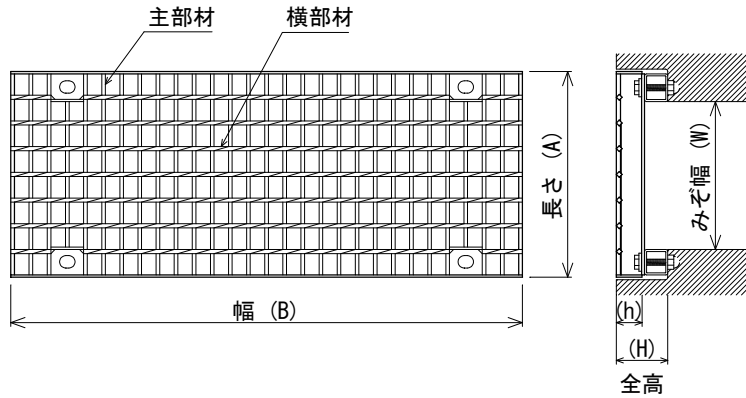
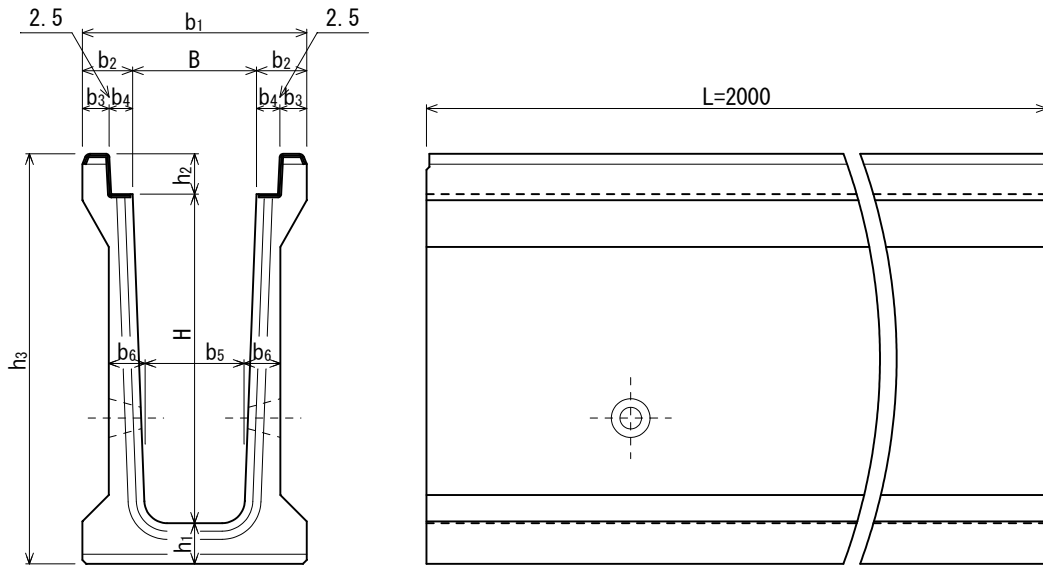

呼び名	みぞ幅 W (mm)	寸法 (mm)				参考重量 (kg)
		(A)	(B)	(H)	(h)	
GFK 30-100	300	400	995	100	50	36
GFK 40-110	400	500	995	110	60	49
GFK 50-125	500	610	995	125	75	67

\*細目タイプも対応できます。

呼び名	寸法 (mm)											参考重量 (kg)
	B	H	b <sub>1</sub>	b <sub>2</sub>	b <sub>3</sub>	b <sub>4</sub>	b <sub>5</sub>	b <sub>6</sub>	h <sub>1</sub>	h <sub>2</sub>	h <sub>3</sub>	
GLU- 306	300	600	535	117.5	60	55	250	80	80	100	780	727
GLU- 307	300	700	535	117.5	60	55	245	85	85	100	885	825
GLU- 308	300	800	535	117.5	60	55	240	90	90	100	990	930
GLU- 309	300	900	535	117.5	60	55	235	95	95	100	1095	1043
GLU-3010	300	1000	535	117.5	60	55	230	100	100	100	1200	1163
GLU- 406	400	600	635	117.5	60	55	350	80	80	110	790	770
GLU- 407	400	700	635	117.5	60	55	345	85	85	110	895	872
GLU- 408	400	800	635	117.5	60	55	340	90	90	110	1000	979
GLU- 409	400	900	635	117.5	60	55	335	95	95	110	1105	1095
GLU-4010	400	1000	635	117.5	60	55	330	100	100	110	1210	1217
GLU- 507	500	700	755	127.5	65	60	445	90	90	125	915	997
GLU- 508	500	800	755	127.5	65	60	440	90	90	125	1015	1065
GLU- 509	500	900	755	127.5	65	60	435	95	95	125	1120	1183
GLU-5010	500	1000	755	127.5	65	60	430	100	100	125	1225	1307

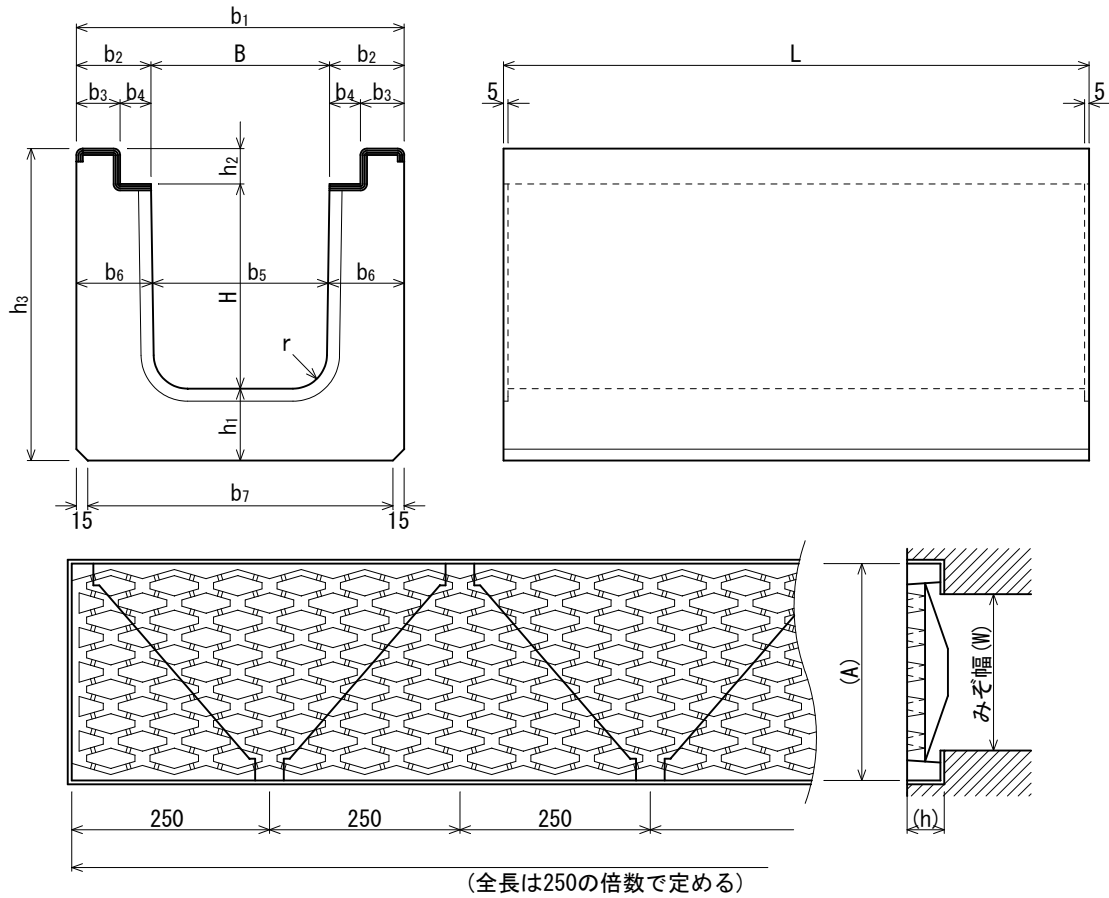

呼び名	みぞ幅 W (mm)	寸法 (mm)		参考重量 (kg)
		(A)	(h)	
GTR-2535	250	350	50	38
GTR-2541	300	410	50	45
GTR-2551	400	510	50	59
GTR-2555	450	550	50	68
GTR-2560	500	600	65	74
GTR-2570	600	700	65	85

呼び名	寸法 (mm)													参考重量 (kg)	
	B	H	b <sub>1</sub>	b <sub>2</sub>	b <sub>3</sub>	b <sub>4</sub>	b <sub>5</sub>	b <sub>6</sub>	b <sub>7</sub>	h <sub>1</sub>	h <sub>2</sub>	h <sub>3</sub>	r		L
TLU-250	250	290	490	120	65	55	230	130	460	100	50	440	50	2000	666
TLU-303	300	350	540	120	65	55	280	130	510	120	50	520	50	2000	767
TLU-304	300	450	540	120	65	55	280	130	510	120	50	620	50	2000	887
TLU-305	300	550	540	120	65	55	280	130	510	120	50	720	50	2000	1007
TLU-404	400	460	640	120	65	55	380	130	610	120	50	630	50	2000	957
TLU-405	400	560	640	120	65	55	380	130	610	120	50	730	50	2000	1077
TLU-450	450	510	690	120	65	55	430	130	660	120	50	680	50	2000	1046
TLU-505	505	560	775	135	75	60	480	140	730	130	65	755	50	2000	1295
TLU-506	505	660	775	135	75	60	480	140	730	130	65	855	50	2000	1431
TLU-606	600	665	860	130	75	55	560	150	730	130	65	860	50	2000	1482

\*1mも作成できます

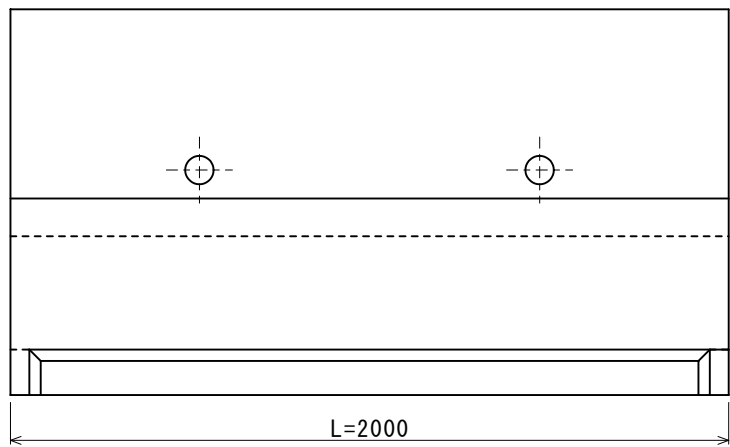
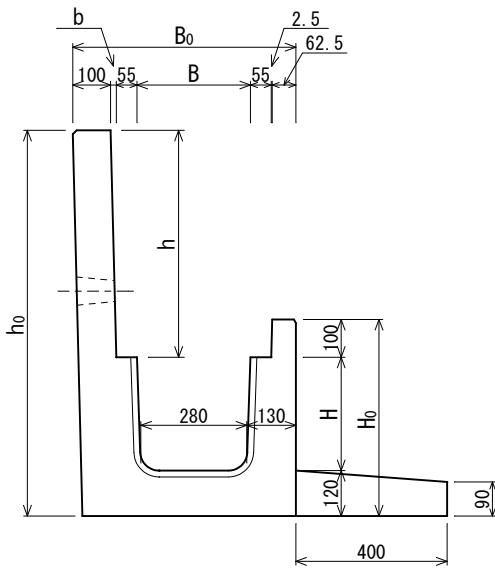
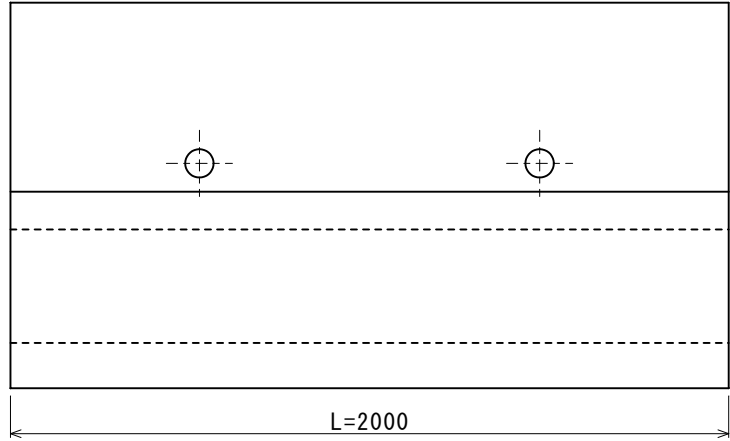
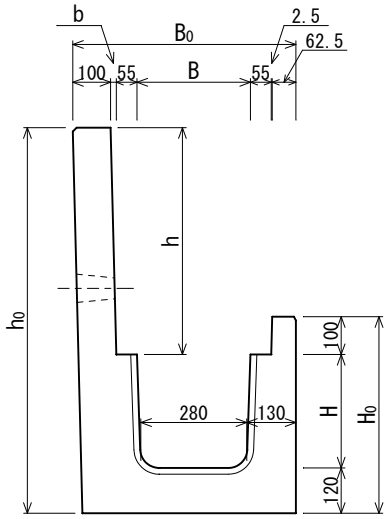

- ①BLU-303-90, 100は底版張出タイプ(\*)での製造になります。
- ②BLU-303-20には水抜き穴は付きません。

呼び名	寸法 (mm)							参考重量 (kg)
	B	H	b	B <sub>0</sub>	H <sub>0</sub>	h	h <sub>0</sub>	
BLU-303-20	300	300	5	580	520	200	620	863
BLU-303-30	300	300	8	583	520	300	720	911
BLU-303-40	300	300	10	585	520	400	820	959
BLU-303-50	300	300	13	588	520	500	920	1007
BLU-303-60	300	300	15	590	520	600	1020	1055
BLU-303-70	300	300	18	593	520	700	1120	1103
BLU-303-80	300	300	20	595	520	800	1220	1151
* BLU-303-90	300	300	23	598	520	900	1320	1401
* BLU-303-100	300	300	25	600	520	1000	1420	1449



## LU2

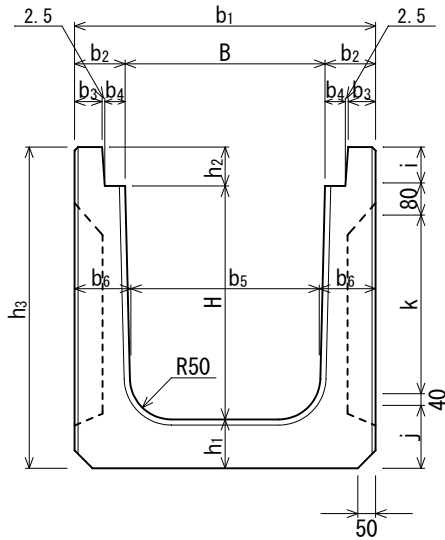

## LU3

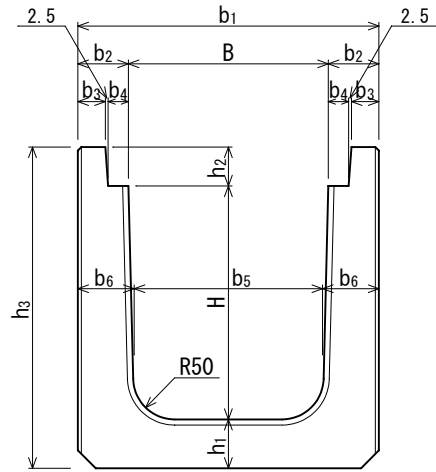

## LU2

呼び名 LU2	寸法 (mm)															横鉄筋		縦鉄筋		参考重量 (kg)
	B	H	L	b <sub>1</sub>	b <sub>2</sub>	b <sub>3</sub>	b <sub>4</sub>	b <sub>5</sub>	b <sub>6</sub>	h <sub>1</sub>	h <sub>2</sub>	h <sub>3</sub>	i	j	k	径	本	径	本	
B300-H300	300	300	4000	540	120	62.5	55	280	130	120	100	520	100	80	220	5	13	5	5	1276
B300-H400	300	400	4000	540	120	62.5	55	280	130	120	100	620	100	80	320	5	13	5	5	1445
B300-H500	300	500	4000	540	120	62.5	55	280	130	120	100	720	100	80	420	6	13	5	5	1614
B300-H600	300	600	4000	540	120	62.5	55	280	130	120	100	820	100	80	520	D6	13	6	5	1783
B400-H400	400	400	4000	640	120	62.5	55	380	130	120	110	630	110	80	320	5	13	5	5	1572
B400-H500	400	500	4000	640	120	62.5	55	380	130	120	110	730	110	80	420	6	13	5	5	1741
B400-H600	400	600	2000	640	120	62.5	55	380	130	120	110	830	110	80	520	D6	13	6	5	1910
B500-H500	500	500	2000	760	130	67.5	60	480	140	130	125	755	125	90	420	6	7	5	5	1079
B500-H600	500	600	2000	760	130	67.5	60	480	140	130	125	855	125	90	520	D6	7	6	5	1187

## LU3

呼び名 LU3	寸法 (mm)													横鉄筋		縦鉄筋		参考重量 (kg)
	B	H	L	b <sub>1</sub>	b <sub>2</sub>	b <sub>3</sub>	b <sub>4</sub>	b <sub>5</sub>	b <sub>6</sub>	h <sub>1</sub>	h <sub>2</sub>	h <sub>3</sub>	径	本	径	本		
B300-H300	300	300	4000	540	120	62.5	55	280	130	120	100	520	5	16	5	7	1475	
B300-H400	300	400	4000	540	120	62.5	55	280	130	120	100	620	5	16	5	7	1715	
B300-H500	300	500	4000	540	120	62.5	55	280	130	120	100	720	6	16	5	7	1955	
B300-H600	300	600	2000	540	120	62.5	55	280	130	120	100	820	D6	8	6	7	1097	
B300-H700	300	700	2000	540	120	62.5	55	280	130	120	100	920	D6	10	6	7	1217	
B400-H400	400	400	4000	640	120	62.5	55	380	130	120	110	630	5	16	5	7	1842	
B400-H500	400	500	4000	640	120	62.5	55	380	130	120	110	730	6	16	5	7	2082	
B400-H600	400	600	2000	640	120	62.5	55	380	130	120	110	830	D6	8	6	7	1161	
B450-H450	450	450	2000	690	120	62.5	55	430	130	120	110	680	6	8	5	7	1007	
B500-H500	500	500	2000	760	130	67.5	60	480	140	130	125	755	D6	8	5	7	1208	
B500-H600	500	600	2000	760	130	67.5	60	480	140	130	125	855	6	8	6	7	1338	
B500-H700	500	700	2000	760	130	67.5	60	480	140	130	125	955	D6	10	6	7	1468	

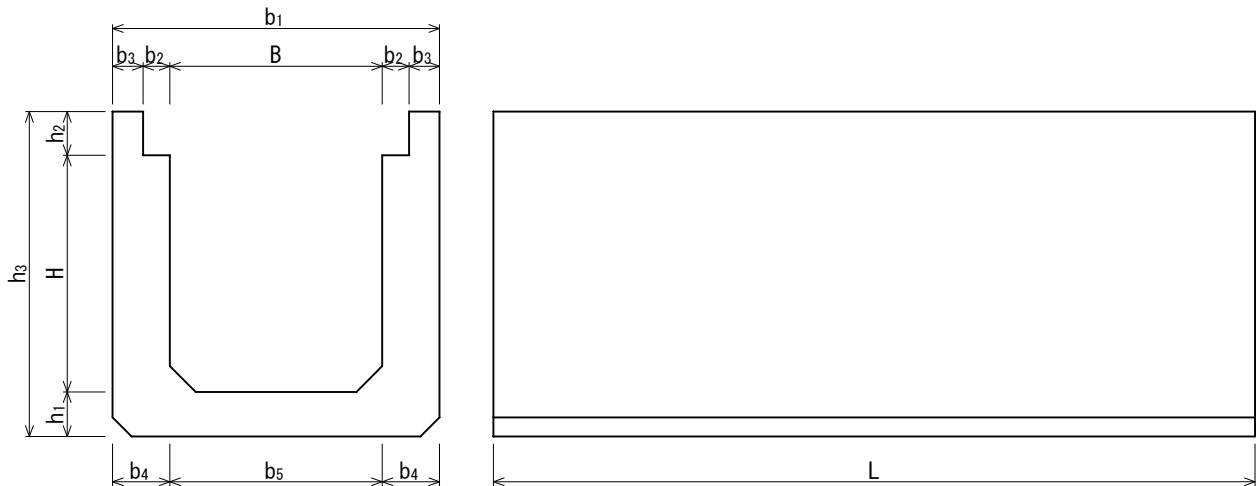

LU3

呼び名 LU3	寸法 (mm)											参考重量 (kg)
	B	H	L	b <sub>1</sub>	b <sub>2</sub>	b <sub>3</sub>	b <sub>4</sub>	b <sub>5</sub>	h <sub>1</sub>	h <sub>2</sub>	h <sub>3</sub>	
B 600-H 400	600	400	2000	900	70	80	150	600	120	130	650	1242
B 600-H 500	600	500	2000	900	70	80	150	600	120	130	750	1386
B 600-H 600	600	600	2000	900	70	80	150	600	120	130	850	1530
B 800-H 600	800	600	2000	1100	70	80	150	800	150	150	880	1804
B 800-H 700	800	700	2000	1100	70	80	150	800	150	150	980	1948
B 800-H 800	800	800	2000	1100	70	80	150	800	150	150	1080	2092
B1000-H 600	1000	600	2000	1300	80	70	150	1000	150	150	900	1949
B1000-H 700	1000	700	2000	1300	80	70	150	1000	150	150	1000	2093
B1000-H 800	1000	800	2000	1300	80	70	150	1000	150	150	1100	2237
B1000-H 900	1000	900	2000	1300	80	70	150	1000	150	150	1200	2381
B1000-H1000	1000	1000	2000	1300	80	70	150	1000	150	150	1300	2525
B1200-H 600	1200	600	2000	1500	80	70	160	1180	130	150	880	1962
B1200-H 700	1200	700	2000	1500	80	70	160	1180	130	150	980	2106
B1200-H 800	1200	800	2000	1500	80	70	160	1180	130	150	1080	2250
B1200-H 900	1200	900	2000	1500	80	70	160	1180	130	150	1180	2394
B1200-H1000	1200	1000	2000	1500	80	70	160	1180	130	150	1280	2538
B1200-H1100	1200	1100	2000	1500	80	70	160	1180	130	150	1380	2682
B1200-H1200	1200	1200	2000	1500	80	70	160	1180	130	150	1480	2826

ロング用受台 (600×300×60)

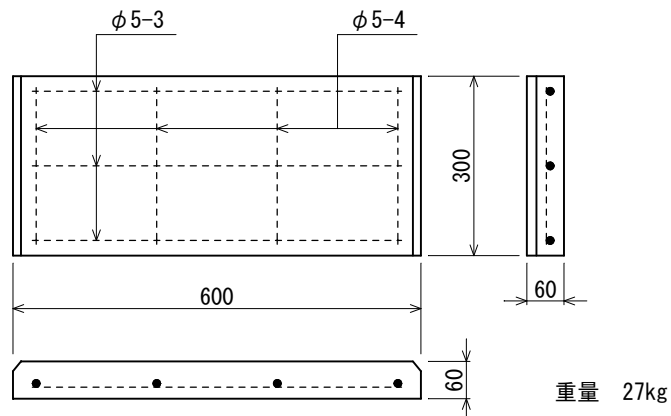

# 落蓋式U形側溝（車道仕様）

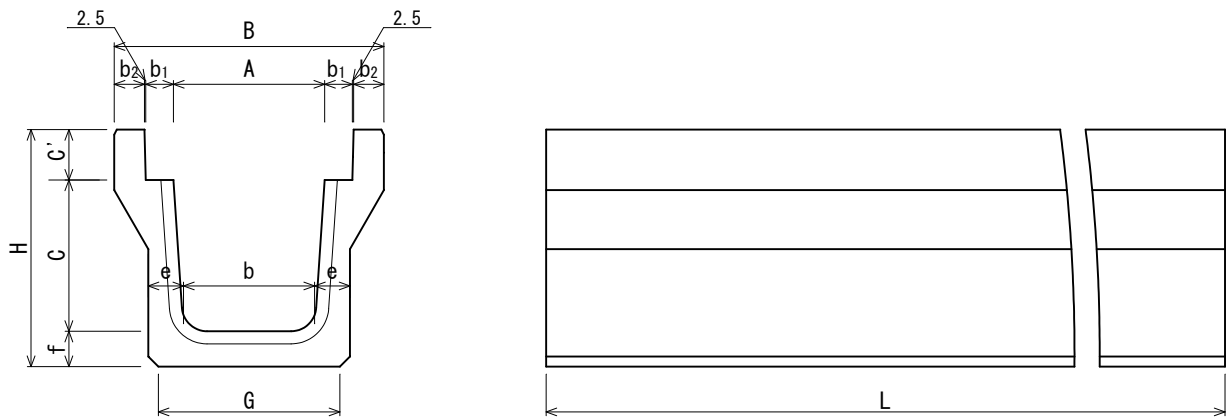

呼び名	寸法 (mm)												参考重量 (kg)
	A	C	B	b	b <sub>1</sub>	b <sub>2</sub>	C'	e	f	G	H	L	
F- 24A	240	240	445	220	40	60	100	70	70	260	410	2000	344
F- 30A	300	300	525	260	50	60	100	80	80	330	480	2000	456
F- 36A	360	360	585	310	50	60	100	85	85	340	545	2000	525
F- 40A	400	400	625	360	50	60	110	85	85	400	595	2000	583
F- 45A	450	450	675	400	50	60	110	75	75	490	635	2000	575
F- 50A	500	500	735	440	50	65	110	90	90	480	700	2000	725
F-50x70A	500	700	735	440	50	65	110	95	95	500	905	2000	921
F-60x70A	600	700	880	560	60	77.5	130	95	100	600	930	2000	1052
F-60x80A	600	800	875	540	60	75	130	100	100	600	1030	2000	1147
F-60x90A	600	900	875	540	60	75	130	100	105	600	1135	2000	1230

# 落蓋式U形側溝蓋（車道仕様）

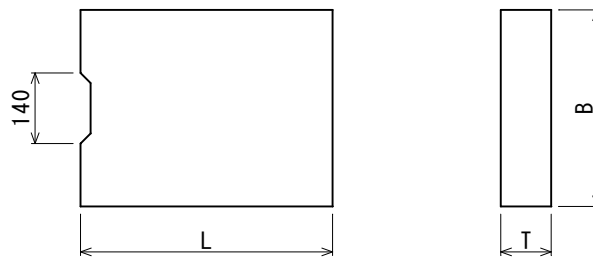

呼び名	寸法 (mm)			参考重量 (kg)
	B	T	L	
24A用蓋	310	100	500	38
30A用蓋	390	100	500	47
36A用蓋	450	100	500	54
40A用蓋	490	110	500	65
45A用蓋	540	110	500	71
50A用蓋	590	110	500	78
60A用蓋	710	130	500	111

# 道路用鉄筋コンクリート側溝



1種 歩道用  
3種 T-25 JIS A 5372

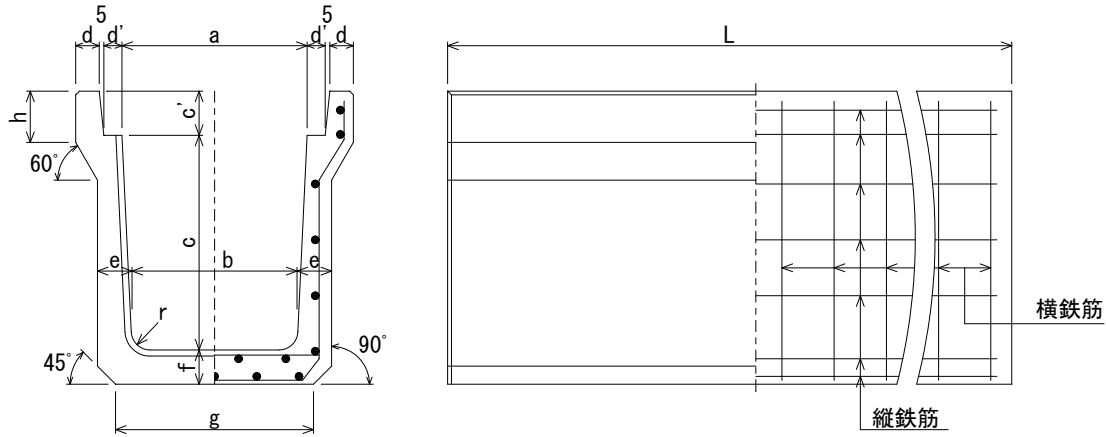

種類	呼び名	寸法 (mm)											横鉄筋				縦鉄筋		参考重量 (kg)	
		a	b	c	c'	d	d'	e	f	g	h	r	L	外側		内側		径		本
1種	250	250	230	250	90	40	55	55	55	300	120	50	2000	4	10			4	11	271
	300A	300	280	300	95	40	55	60	60	360	120	50	2000	4	10			4	11	320
	300B	300	270	400	95	40	55	65	65	360	120	50	2000	4	10			4	13	392
	300C	300	260	500	95	40	55	70	70	360	120	50	2000	5	10			4	15	469
	400A	400	370	400	110	40	55	65	65	460	135	50	2000	5	10			4	14	425
	400B	400	360	500	110	40	55	70	70	460	135	50	2000	5	10			4	16	504
	500A	500	460	500	125	45	60	70	70	560	150	50	2000	5	10			4	17	552
	500B	500	450	600	125	45	60	75	75	560	150	50	2000	6	10			4	21	639
3種	250	250	230	250	90	45	55	65	65	300	120	50	2000	5	20	5	20	4	13	307
	300A	300	280	300	95	50	55	70	70	360	140	50	2000	5	24	5	24	4	13	390
	300B	300	270	400	95	50	55	70	70	330	140	50	2000	D6	19	D6	10	4	15	451
	300C	300	260	500	95	50	55	80	80	340	140	50	2000	D6	21	D6	11	4	17	556
	400A	400	370	400	110	55	55	70	70	430	140	50	2000	D6	23	D6	12	4	17	504
	400B	400	360	500	110	55	55	80	80	440	140	50	2000	D6	23	D6	12	4	19	611
	500A	500	460	500	125	60	60	80	80	540	155	50	2000	D6	23	D6	12	4	20	685
	500B	500	450	600	125	60	60	90	90	550	155	50	2000	D6	25	D6	13	4	24	837

# 道路用鉄筋コンクリート側溝ふた

JIS A 5372

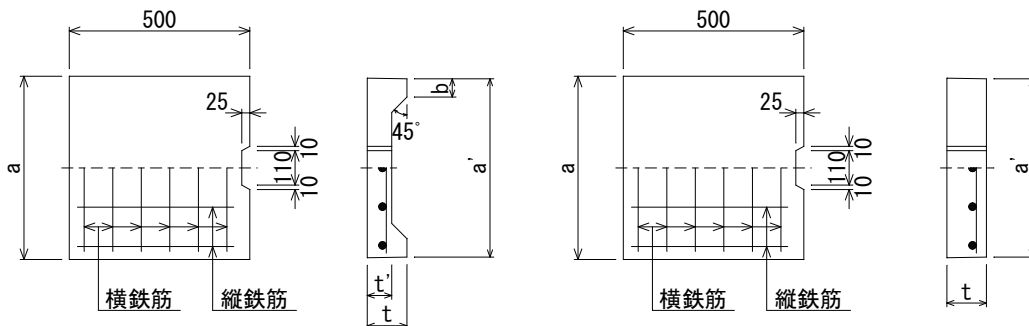

種類	呼び名	寸法 (mm)					横鉄筋		縦鉄筋		参考重量 (kg)
		a	a'	b	t	t'	径	本	径	本	
1種	250	362	352	50	90	55	4.0	6	4.0	3	29
	300	412	402	51	95	55	4.0	6	4.0	4	33
	400	512	502	51	110	65	4.0	6	4.0	5	47
	500	622	612	56	125	75	4.0	6	4.0	6	65
3種	250	362	352	—	90	—	D6	6	4.0	3	37
	300	412	402	—	95	—	D10	4	6.0	4	45
	400	512	502	—	110	—	D10	5	6.0	5	65
	500	622	612	—	125	—	D10	6	6.0	6	91

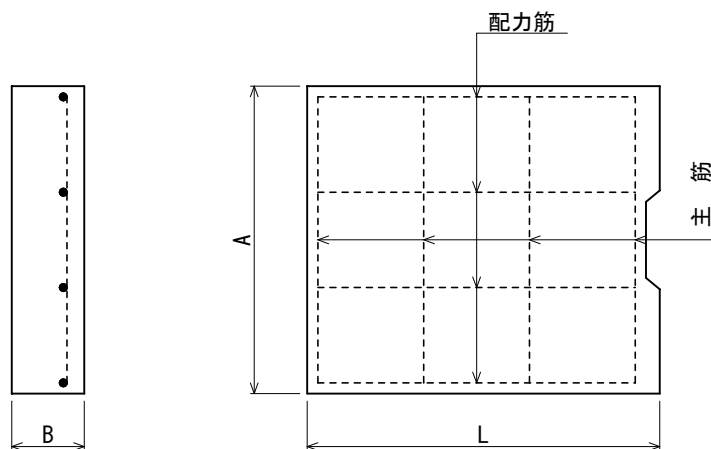

用途	呼び名	寸法 (mm)			主筋		配力筋		参考重量 (kg)
		A	B	L	径	本	径	本	
歩道用	43×10×50	430	100	500	D13	4	D13	4	53
	53×10×50	530	100	500	D13	4	D13	4	66
	63×10×50	630	100	500	D13	4	D13	4	78
	73×10×50	730	100	500	D13	4	D13	4	91
	83×10×50	830	100	500	D13	4	D13	4	103
車道用	39×10×50	390	100	500	D10	8	D10	4	47
	43×10×50	430	100	500	D13	9	D13	4	53
	43×11×50	430	110	500	D13	9	D13	4	58
	43×13×50	430	130	500	D13	7	D13	4	69
	49×10×50	490	100	500	D13	9	D13	4	59
	53×10×50	530	100	500	D13	9	D13	4	66
	53×12×50	530	120	500	D13	9	D13	4	78
	53×13×50	530	130	500	D13	9	D13	4	86
	59×10×50	590	100	500	D13	9	D13	5	71
	63×13×50	630	130	500	D13	9	D13	4	101
	73×13×50	730	130	500	D13	9	D13	5	116
	83×13×50	830	130	500	D13	9	D13	5	133
	93×13×50	930	130	500	D13	9	D13	5	145
	73×15×50	730	150	500	D13	9	D13	5	134
83×15×50	830	150	500	D13	9	D13	5	152	
93×15×50	930	150	500	D13	9	D13	5	170	



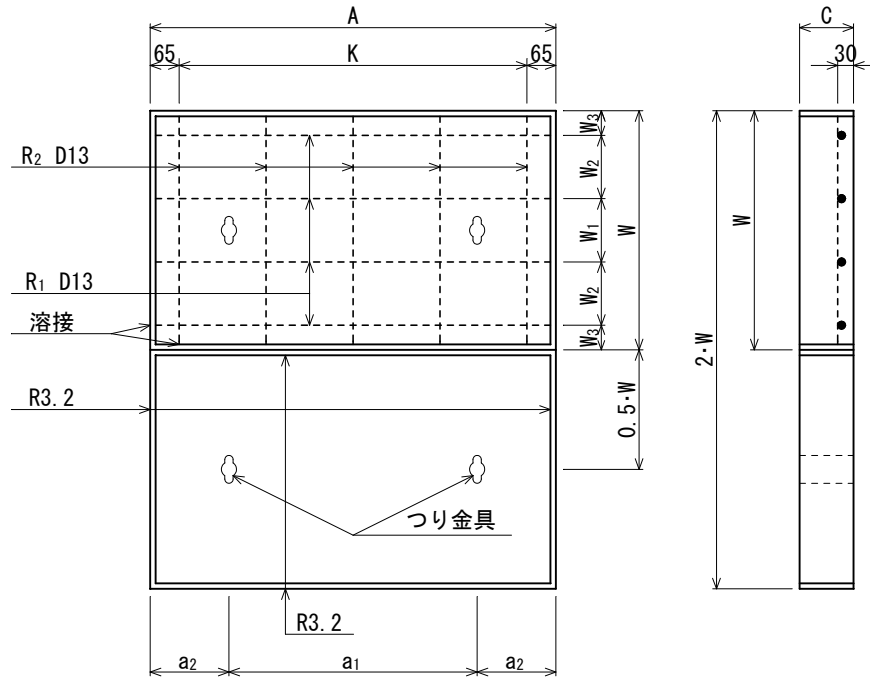

呼び名	寸法 (mm)										R <sub>1</sub> 鉄筋 本数	R <sub>2</sub> 鉄筋 本数	参考重量 (kg)
	A	W	C	K	W <sub>1</sub>	W <sub>2</sub>	W <sub>3</sub>	a <sub>1</sub>	a <sub>2</sub>				
GC 1型	430	360	100	300 (=3@100)	80	70	70	210	110	4	4	41	
GC 2型	430	410	100	300 (=3@100)	100	80	75	210	110	4	4	47	
GC 3型	480	360	100	350 (=4@ 88)	80	70	70	260	110	4	5	46	
GC 4型	480	410	100	350 (=4@ 88)	100	80	75	260	110	4	5	52	
GC 5型	530	360	100	400 (=4@100)	80	70	70	310	110	4	5	51	
GC 6型	530	410	100	400 (=4@100)	100	80	75	310	110	4	5	58	
GC 7型	530	460	100	400 (=4@100)	100	100	80	310	110	4	5	64	
GC 8型	630	310	100	500 (=5@100)	80	60	55	410	110	4	6	52	
GC 9型	630	410	100	500 (=5@100)	100	80	75	410	110	4	6	68	
GC 10型	630	460	100	500 (=5@100)	100	100	80	410	110	4	6	76	
GC 11型	730	360	100	600 (=6@100)	80	70	70	510	110	4	7	69	
GC 12型	730	460	100	600 (=6@100)	100	100	80	510	110	4	7	88	
GC 13型	730	510	100	600 (=6@100)	240 (=3@80)	70	65	510	110	6	7	97	
GC 14型	830	410	100	700 (=7@100)	100	80	75	390	220	4	8	89	
GC 15型	830	510	100	700 (=7@100)	240 (=3@80)	70	65	390	220	6	8	110	
GC 16型	830	560	100	700 (=7@100)	240 (=3@80)	80	80	390	220	6	8	121	
GC 17型	930	460	100	800 (=8@100)	100	100	80	490	220	4	9	112	
GC 18型	930	560	100	800 (=8@100)	240 (=3@80)	80	80	490	220	6	9	135	
GC 19型	1030	510	100	900 (=9@100)	240 (=3@80)	70	65	590	220	6	10	137	
GC 20型	1030	560	100	900 (=9@100)	240 (=3@80)	80	80	590	220	6	10	150	
GC 21型	1130	560	100	1000 (=10@100)	240 (=3@80)	80	80	690	220	6	11	164	

# 長尺側溝F型 (12×12) 歩道用

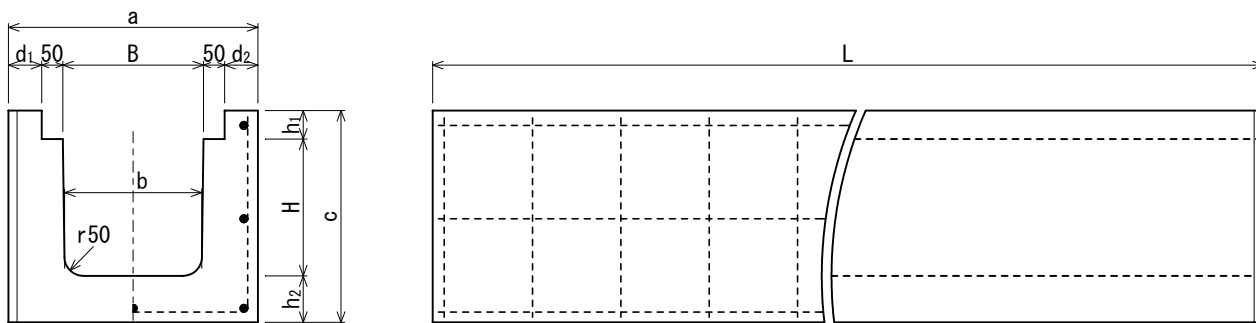

呼び名	寸法 (mm)										参考重量 (kg)
	B	H	L	a	b	c	d <sub>1</sub>	d <sub>2</sub>	h <sub>1</sub>	h <sub>2</sub>	
F4-30	300	300	4000	540	290	450	70	70	50	100	1277
F4-35	300	350	4000	540	290	500	70	70	50	100	1392
F4-40	300	400	4000	540	290	550	70	70	50	100	1504
F4-45	300	450	4000	540	290	600	70	70	50	100	1620
F4-50	300	500	4000	540	290	650	70	70	50	100	1734
F2-55	300	550	2000	540	290	700	70	70	50	100	925
F2-60	300	600	2000	540	290	750	70	70	50	100	983
F2-65	300	650	2000	540	290	800	70	70	50	100	1043
F2-75	300	750	2000	540	290	950	70	70	50	150	1309
F2-85	300	850	2000	540	290	1050	70	70	50	150	1427

# 長尺側溝H型 (12×12) 歩車道用

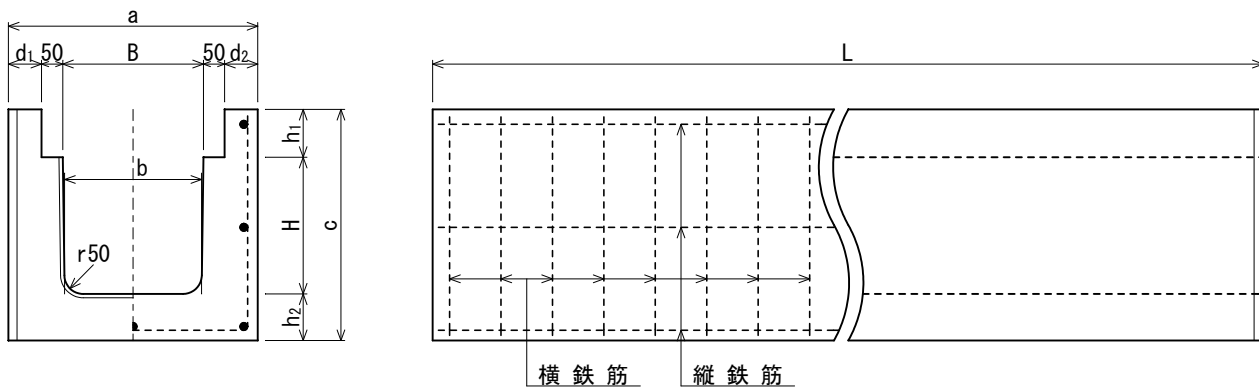

呼び名	寸法 (mm)										参考重量 (kg)
	B	H	L	a	b	c	d <sub>1</sub>	d <sub>2</sub>	h <sub>1</sub>	h <sub>2</sub>	
H4-24A	240	240	4000	480	230	440	70	70	100	100	1148
H4-30	300	300	4000	540	290	500	70	70	100	100	1342
H4-35	300	350	4000	540	290	550	70	70	100	100	1457
H4-40	300	400	4000	540	290	600	70	70	100	100	1573
H4-45	300	450	4000	540	290	650	70	70	100	100	1687
H4-50	300	500	4000	540	290	700	70	70	100	100	1803
H2-55	300	550	2000	540	290	750	70	70	100	100	963
H2-60	300	600	2000	540	290	800	70	70	100	100	1020
H2-70	300	700	2000	540	290	950	70	70	100	150	1284
H2-80	300	800	2000	540	290	1050	70	70	100	150	1402
H2-90	300	900	2000	540	290	1150	70	70	100	150	1519

# 長尺側溝 (12×15) 車道用

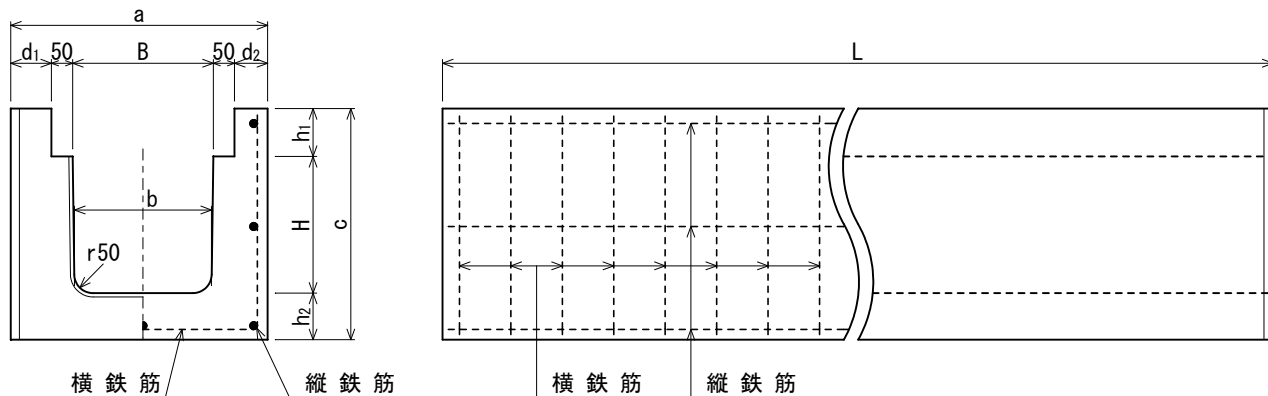

呼び名	寸法 (mm)										参考重量 (kg)
	B	H	L	a	b	c	d <sub>1</sub>	d <sub>2</sub>	h <sub>1</sub>	h <sub>2</sub>	
4-30	300	300	4000	570	290	500	100	70	100	100	1483
4-35	300	350	4000	570	290	550	100	70	100	100	1612
4-40	300	400	4000	570	290	600	100	70	100	100	1742
4-45	300	450	4000	570	290	650	100	70	100	100	1870
4-50	300	500	4000	570	290	700	100	70	100	100	2000
2-55	300	550	2000	570	290	750	100	70	100	100	1069
2-60	300	600	2000	570	290	800	100	70	100	100	1133
2-70	300	700	2000	570	290	950	100	70	100	150	1420
2-80	300	800	2000	570	290	1050	100	70	100	150	1553
2-90	300	900	2000	570	290	1150	100	70	100	150	1684

# 長尺側溝D型 (15×15) 横断用

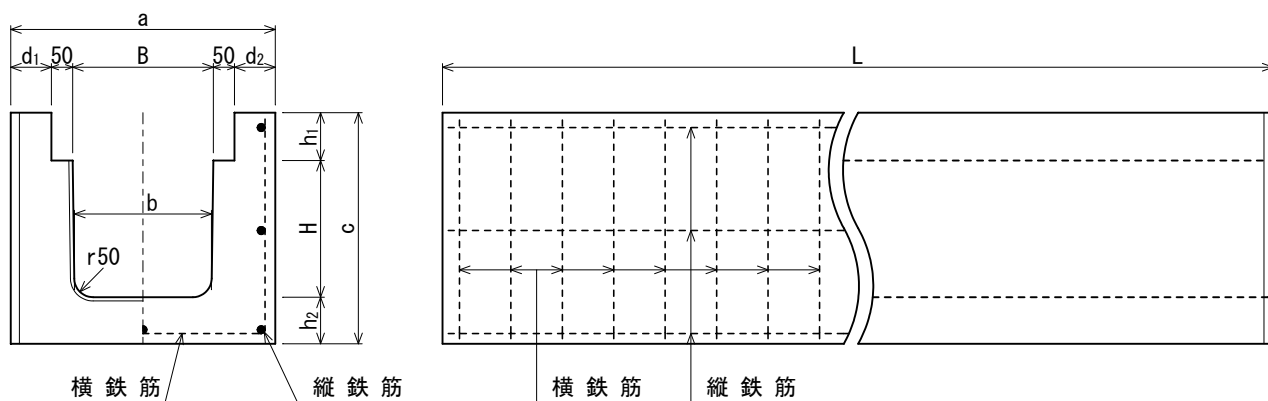

呼び名	寸法 (mm)										参考重量 (kg)
	B	H	L	a	b	c	d <sub>1</sub>	d <sub>2</sub>	h <sub>1</sub>	h <sub>2</sub>	
D4-30	300	300	4000	600	290	500	100	100	100	100	1624
D4-35	300	350	4000	600	290	550	100	100	100	100	1768
D4-40	300	400	4000	600	290	600	100	100	100	100	1912
D4-45	300	450	4000	600	290	650	100	100	100	100	2053
D2-50	300	500	2000	600	290	700	100	100	100	100	1098
D2-55	300	550	2000	600	290	750	100	100	100	100	1175
D2-60	300	600	2000	600	290	800	100	100	100	100	1246
D2-70	300	700	2000	600	290	950	100	100	100	150	1557
D2-80	300	800	2000	600	290	1050	100	100	100	150	1704
D2-90	300	900	2000	600	290	1150	100	100	100	150	1850

# 長尺側溝NF型 (12×12) 歩道用

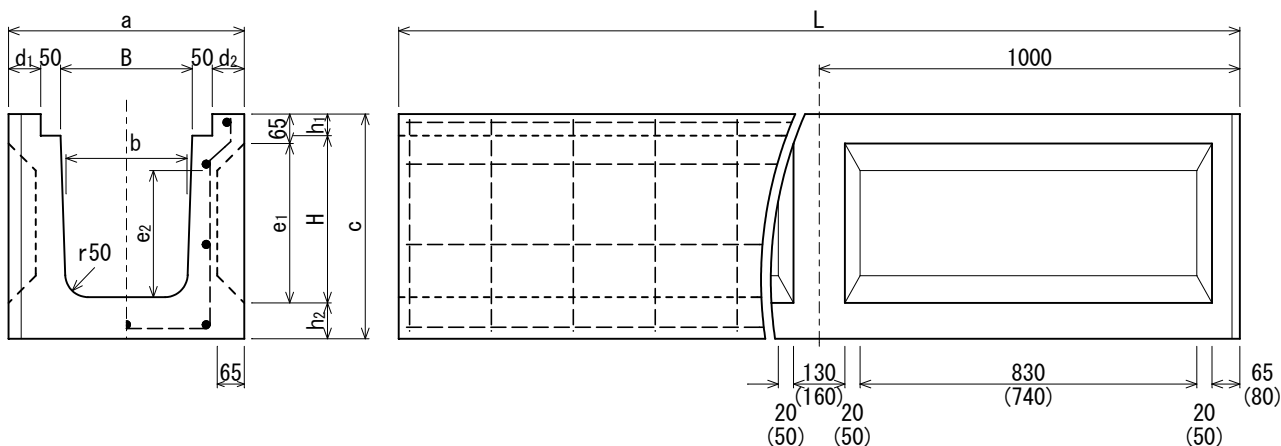

呼び名	寸法 (mm)												参考重量 (kg)
	B	H	L	a	b	c	d <sub>1</sub>	d <sub>2</sub>	e <sub>1</sub>	e <sub>2</sub>	h <sub>1</sub>	h <sub>2</sub>	
NF4-35	300	350	4000	540	290	465	70	70	335	250	50	65	910
NF4-45	300	450	4000	540	290	565	70	70	435	350	50	65	1036
NF4-55	300	550	4000	540	290	680	70	70	520	420	50	80	1297

# 長尺側溝NH型 (12×12) 車道用

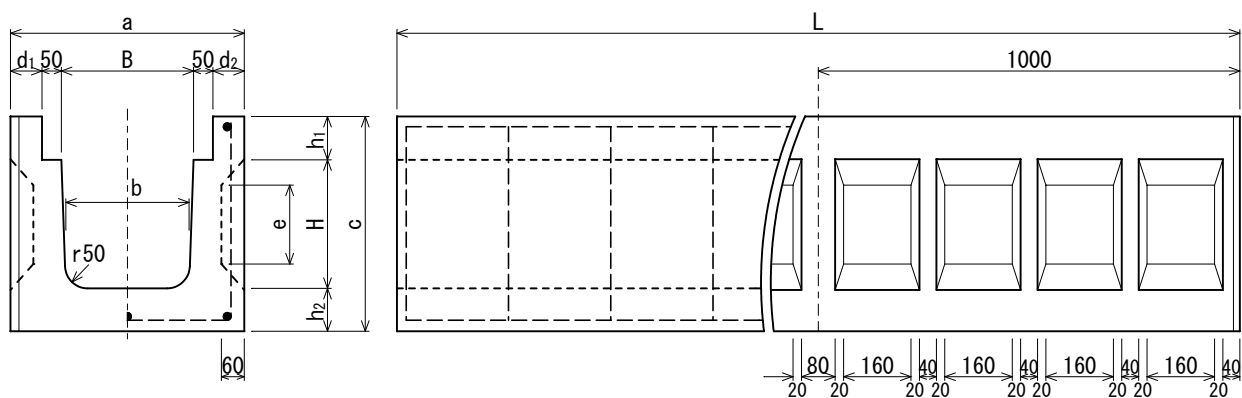

呼び名	寸法 (mm)											参考重量 (kg)
	B	H	L	a	b	c	d <sub>1</sub>	d <sub>2</sub>	e	h <sub>1</sub>	h <sub>2</sub>	
NH4-24A	240	240	4000	480	230	440	70	70	120	100	100	1002
NH4-30	300	300	4000	540	290	500	70	70	180	100	100	1147
NH4-40	300	400	4000	540	290	600	70	70	280	100	100	1297
NH4-50	300	500	4000	540	290	700	70	70	380	100	100	1446

# 長尺側溝N型 (12×15) 車道用

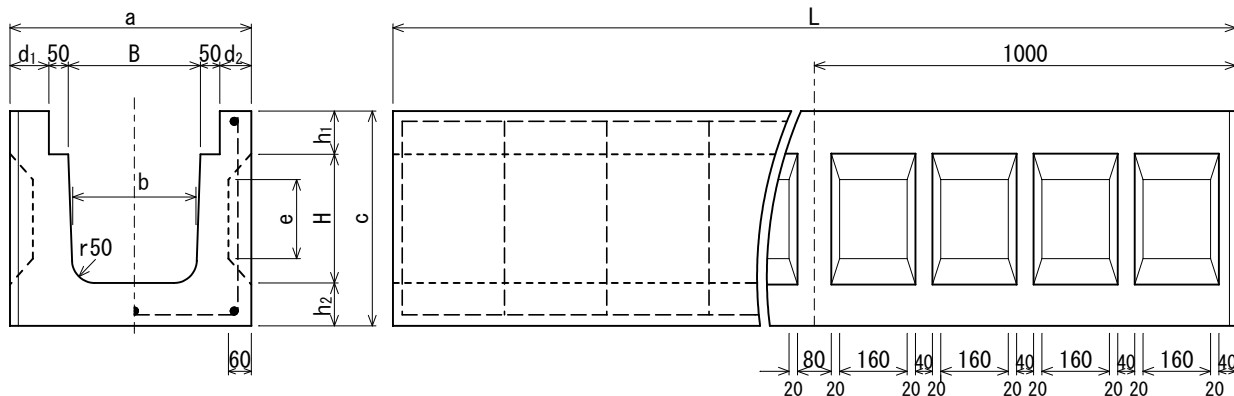

呼び名	寸法 (mm)											参考重量 (kg)
	B	H	L	a	b	c	d <sub>1</sub>	d <sub>2</sub>	e	h <sub>1</sub>	h <sub>2</sub>	
N4-30	300	300	4000	570	290	500	100	70	180	100	100	1288
N4-40	300	400	4000	570	290	600	100	70	280	100	100	1466
N4-50	300	500	4000	570	290	700	100	70	380	100	100	1643
N2-60	300	600	2000	570	290	800	100	70	480	100	100	914

## ロング用受台 (600×300×60)

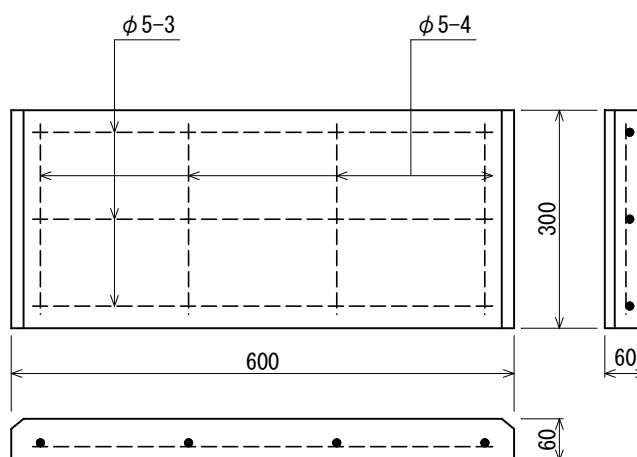

重量 27kg

# ロングU集水桝 (300用)

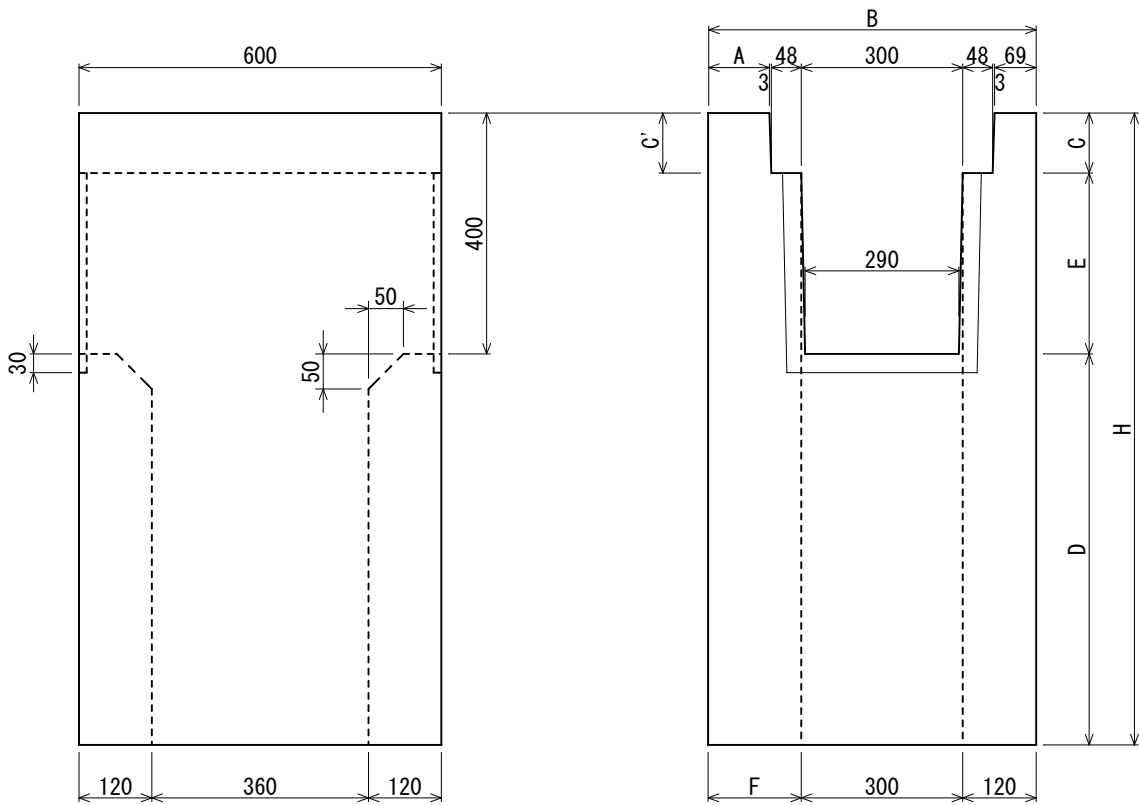
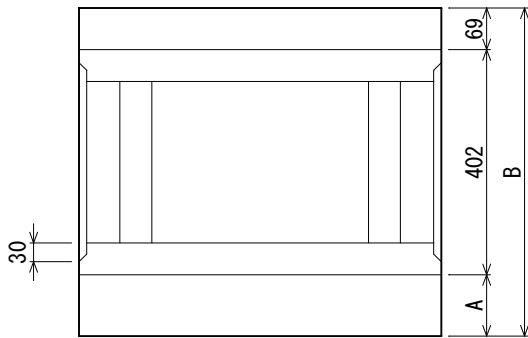

呼 び 名		寸 法 (mm)								参考重量 (kg)
		A	B	C	C'	D	E	F	H	
歩 道 用	ロングU集水桝F 700H	69	540	50	50	300	350	120	700	293
	ロングU集水桝F 800H	69	540	50	50	400	350	120	800	344
	ロングU集水桝F 900H	69	540	50	50	500	350	120	900	395
	ロングU集水桝F1000H	69	540	50	50	600	350	120	1000	445
車 道 用	ロングU集水桝F 750H	99	570	100	100	350	300	150	750	330
	ロングU集水桝F 800H	99	570	100	100	400	300	150	800	351
	ロングU集水桝F 850H	99	570	100	100	450	300	150	850	377
	ロングU集水桝F 900H	99	570	100	100	350	500	150	950	409
	ロングU集水桝F1050H	99	570	100	100	450	500	150	1050	447

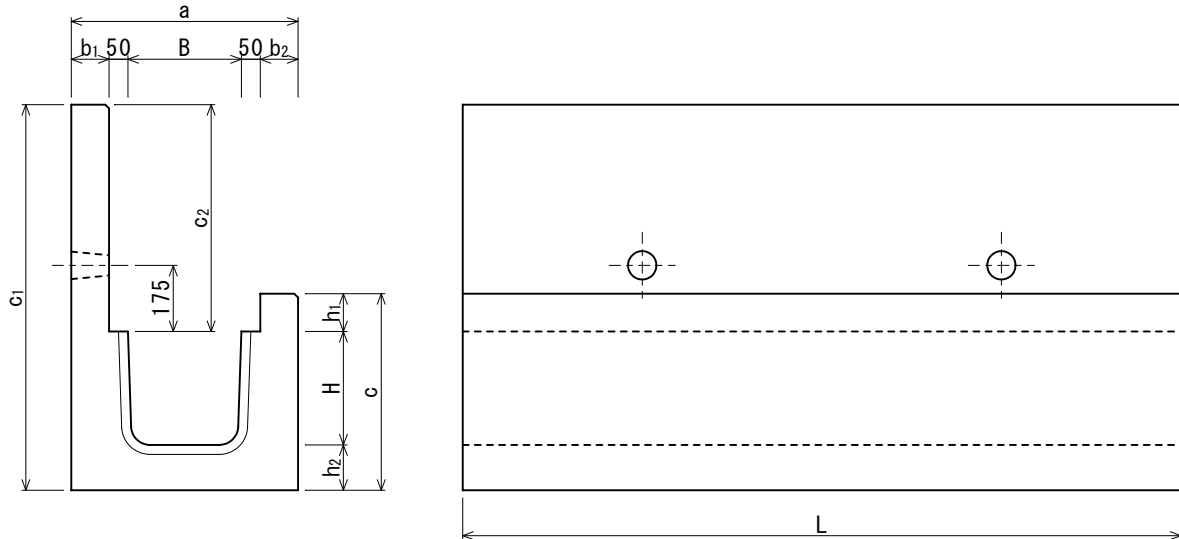

呼び名	寸法 (mm)											参考重量 (kg)
	B	H	L	b <sub>1</sub>	b <sub>2</sub>	a	h <sub>1</sub>	h <sub>2</sub>	c	c <sub>1</sub>	c <sub>2</sub>	
FC2- 20	300	300	2000	100	100	600	100	150	550	650	200	1000
FC2- 30	300	300	2000	100	100	600	100	150	550	750	300	1047
FC2- 40	300	300	2000	100	100	600	100	150	550	850	400	1094
FC2- 50	300	300	2000	100	100	600	100	150	550	950	500	1141
FC2- 60	300	300	2000	100	100	600	100	150	550	1050	600	1188
FC2- 70	300	300	2000	100	100	600	100	150	550	1150	700	1253
FC2- 80	300	300	2000	100	100	600	100	150	550	1250	800	1301
FC2- 90	300	300	2000	100	100	600	100	150	550	1350	900	1349
FC2-100	300	300	2000	100	100	600	100	150	550	1450	1000	1397

※FC2-20には水抜き穴は付きません。

# 埼玉県型溝蓋

(車道用)



網付き

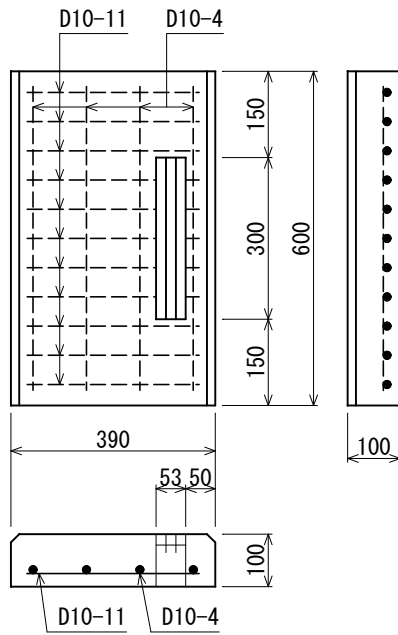

参考重量 56kg

手掛付

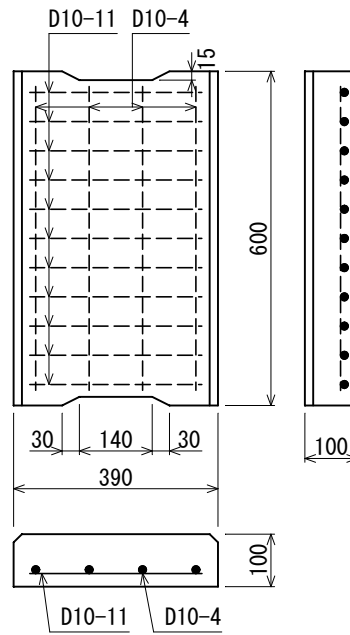

参考重量 56kg

普通型

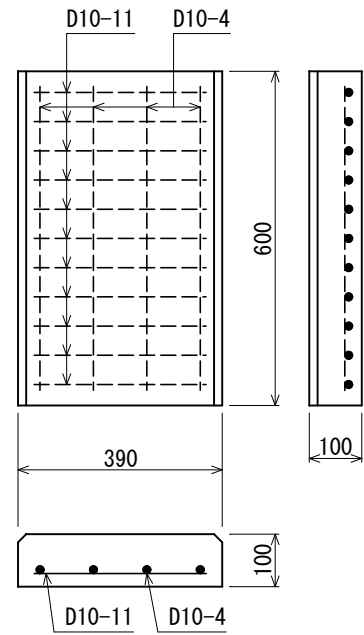

参考重量 57kg

# 埼玉県型溝蓋

(歩道用)

網付き

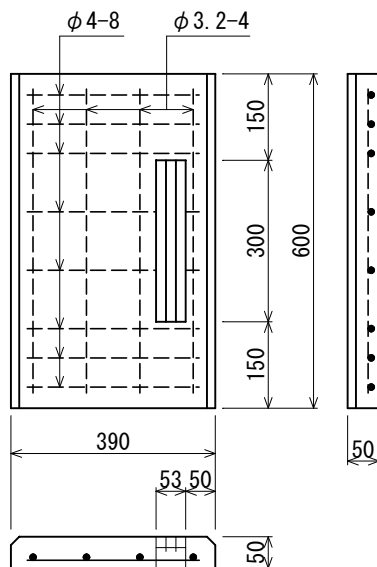

参考重量 28kg

手掛付

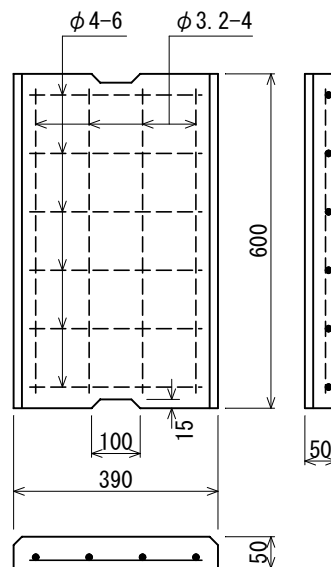

参考重量 28kg

普通型

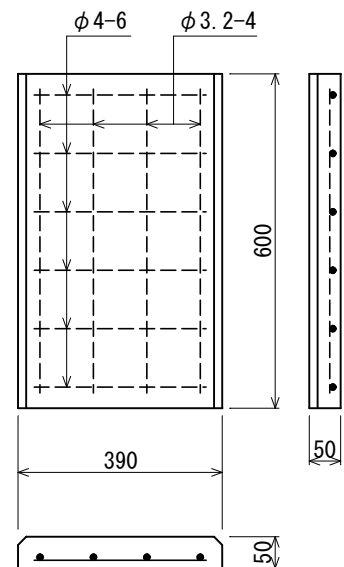

参考重量 28kg



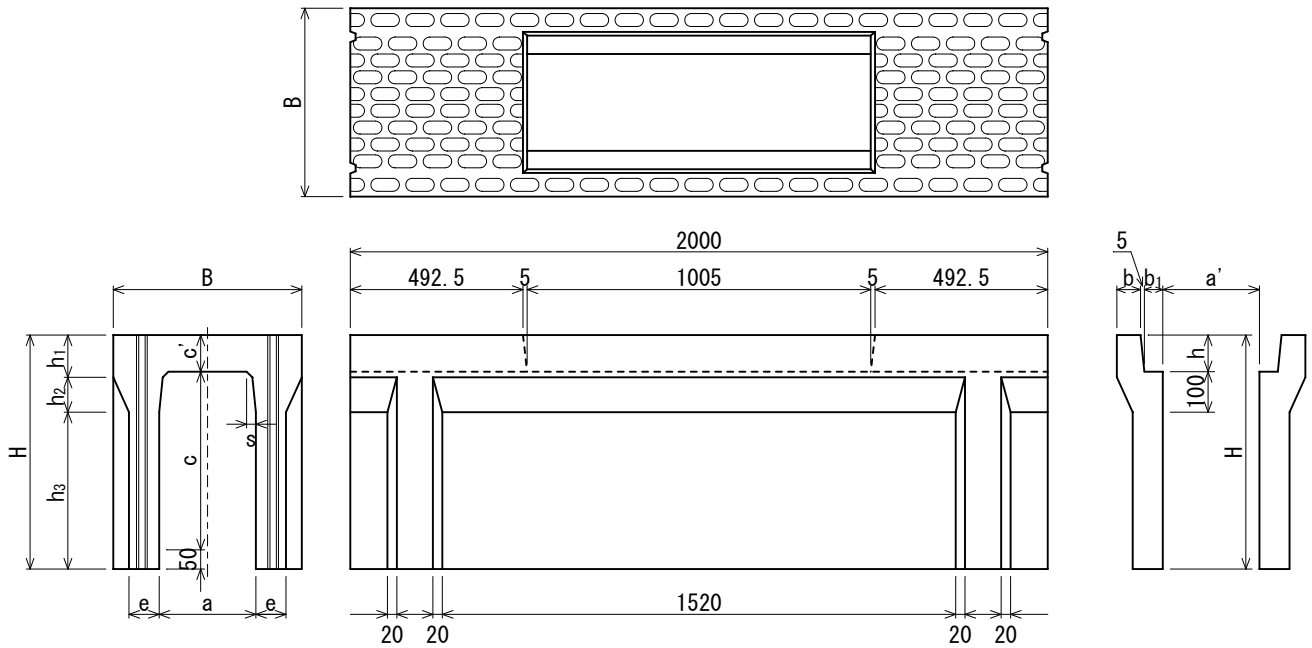

呼び名	寸法 (mm)														参考重量 (kg)											
	B	H	a	a'	c	c'	b	b <sub>1</sub>	e	h	h <sub>1</sub>	h <sub>2</sub>	h <sub>3</sub>	s												
300 × 300	520	450	300	295	300	100	52.5	55	55	100	120	80	220	30	394											
300 × 400		550			400								55		110	320	453									
300 × 500		650			500								70		80	420	512									
300 × 600		750			600								70		80	550	639									
300 × 700		850			700								70		80	650	711									
300 × 800		950			800								70		80	750	783									
300 × 900		1050			900								70		80	870	927									
300 × 1000		1150			1000								80		60	970	1008									
300 × 1100		1250			1100								80		60	1070	1088									
300 × 1200		1350			1200								110		-	-	1527									
300 × 1300		1450			1300								110		-	-	1633									
300 × 1400		1550			1400								110		-	-	1739									
300 × 1500		1650			1500								110		-	-	1844									
400 × 400		630			560								400		395	400	110	57.5	55	60	110	130	90	320	40	523
400 × 500					660											500								60		110
400 × 600	760		600	60	110	520	651																			
400 × 700	860		700	70	90	640	768																			
400 × 800	960		800	70	90	740	840																			
400 × 900	1060		900	70	90	870	1021																			
400 × 1000	1160		1000	85	60	970	1106																			
400 × 1100	1260		1100	85	60	1070	1191																			
400 × 1200	1360		1200	85	60	1170	1276																			
500 × 400	750		575	500	495	400	125	62.5	60	60	125	145		110		300								50		608
500 × 500		675	500			60							130		400	673										
500 × 600		775	600			60							130		500	738										
500 × 700		875	700			60							130		620	855										
500 × 800		975	800			70							110		720	928										
500 × 900		1075	900			70							110		820	1002										
500 × 1000		1175	1000			85							80		950	1194										
500 × 1100		1275	1100			85							80		1050	1280										
500 × 1200		1375	1200			85							80		1150	1366										
500 × 1300		1475	1300			95							60		1270	1559										
500 × 1400		1575	1400			95							60		1370	1653										

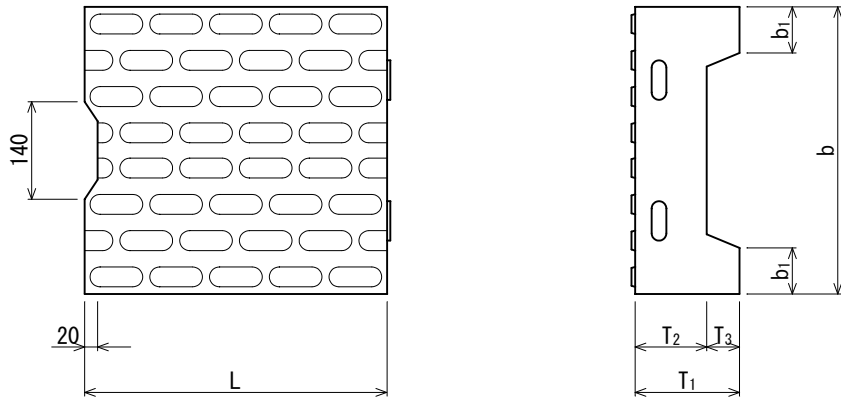

呼び名	寸 法 (mm)						鉄 筋		参考重量 (kg)
	b	b <sub>1</sub>	T <sub>1</sub>	T <sub>2</sub>	T <sub>3</sub>	L	横鉄筋	縦鉄筋	
PCD3-B300	400	55	100	60	40	500	φ 4-6	φ 4-4	36
PCD3-B400	500	55	110	65	45	500	φ 4-6	φ 4-5	47
PCD3-B500	610	60	125	75	50	500	φ 4-6	φ 4-6	65

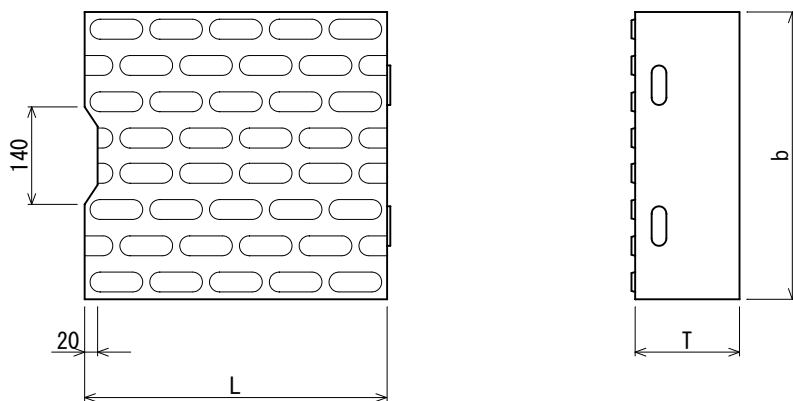

呼び名	寸 法 (mm)			鉄 筋		参考重量 (kg)
	b	T	L	横鉄筋	縦鉄筋	
PCD4-B300	400	100	500	D10-4	D6-4	47
PCD4-B400	500	110	500	D10-5	D6-5	65
PCD4-B500	610	125	500	D10-6	D6-6	91

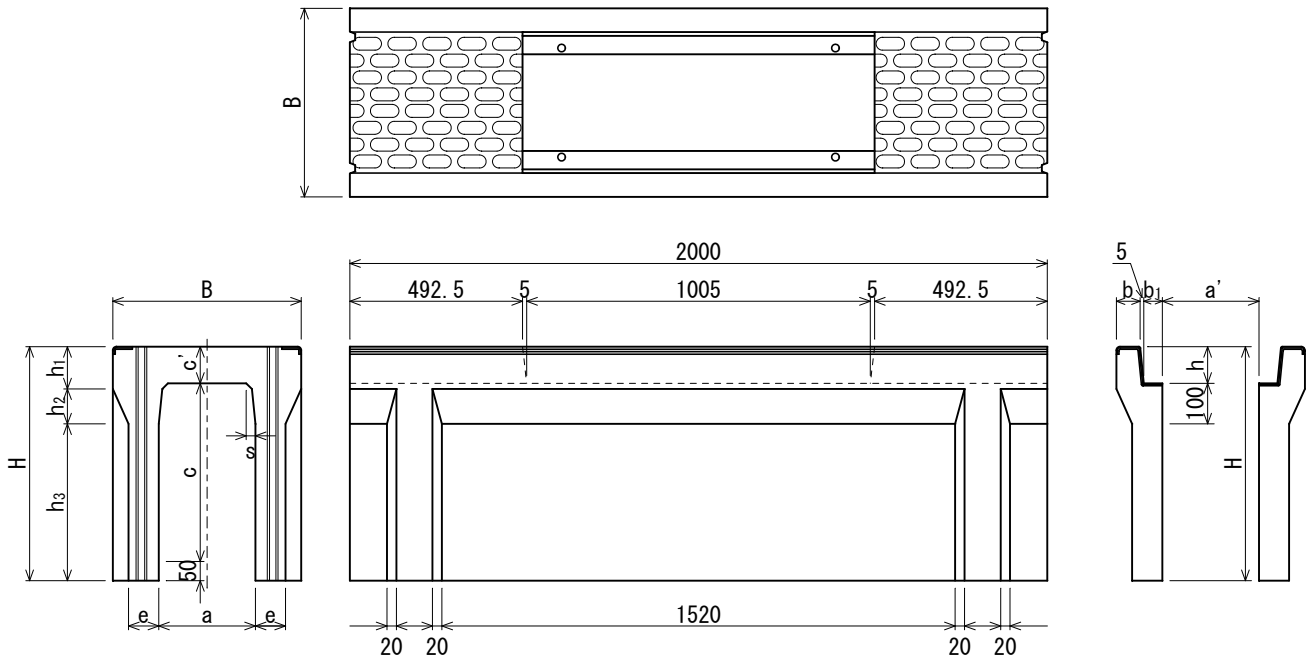

呼び名	寸 法 (mm)														参考重量 (kg)											
	B	H	a	a'	c	c'	b	b <sub>1</sub>	e	h	h <sub>1</sub>	h <sub>2</sub>	h <sub>3</sub>	s												
300 × 300	520	450	300	295	300	100	52.5	55	55	100	120	110	220	30	394											
300 × 400		550			400								320		453											
300 × 500		650			500								420		512											
300 × 600		750			600								550		639											
300 × 700		850			700								650		711											
300 × 800		950			800								750		783											
300 × 900		1050			900								870		927											
300 × 1000		1150			1000								970		1008											
300 × 1100		1250			1100								1070		1088											
300 × 1200		1350			1200										1527											
300 × 1300		1450			1300										1633											
300 × 1400		1550			1400										1739											
300 × 1500		1650			1500										1844											
400 × 400		630			560								400		395	400	110	57.5	55	60	110	130	110	320	40	523
400 × 500					660											500								420		587
400 × 600	760		600	520	651																					
400 × 700	860		700	640	768																					
400 × 800	960		800	740	840																					
400 × 900	1060		900	870	1021																					
400 × 1000	1160		1000	970	1106																					
400 × 1100	1260		1100	1070	1191																					
400 × 1200	1360		1200	1170	1276																					
500 × 400	750		575	500	495	400	125	62.5	60	60	125	145		130		50								300		608
500 × 500		675	500			400							673													
500 × 600		775	600			500							738													
500 × 700		875	700			620							855													
500 × 800		975	800			720							928													
500 × 900		1075	900			820							1002													
500 × 1000		1175	1000			950							1194													
500 × 1100		1275	1100			1050							1280													
500 × 1200		1375	1200			1150							1366													
500 × 1300		1475	1300			1270							1559													
500 × 1400		1575	1400			1370							1653													

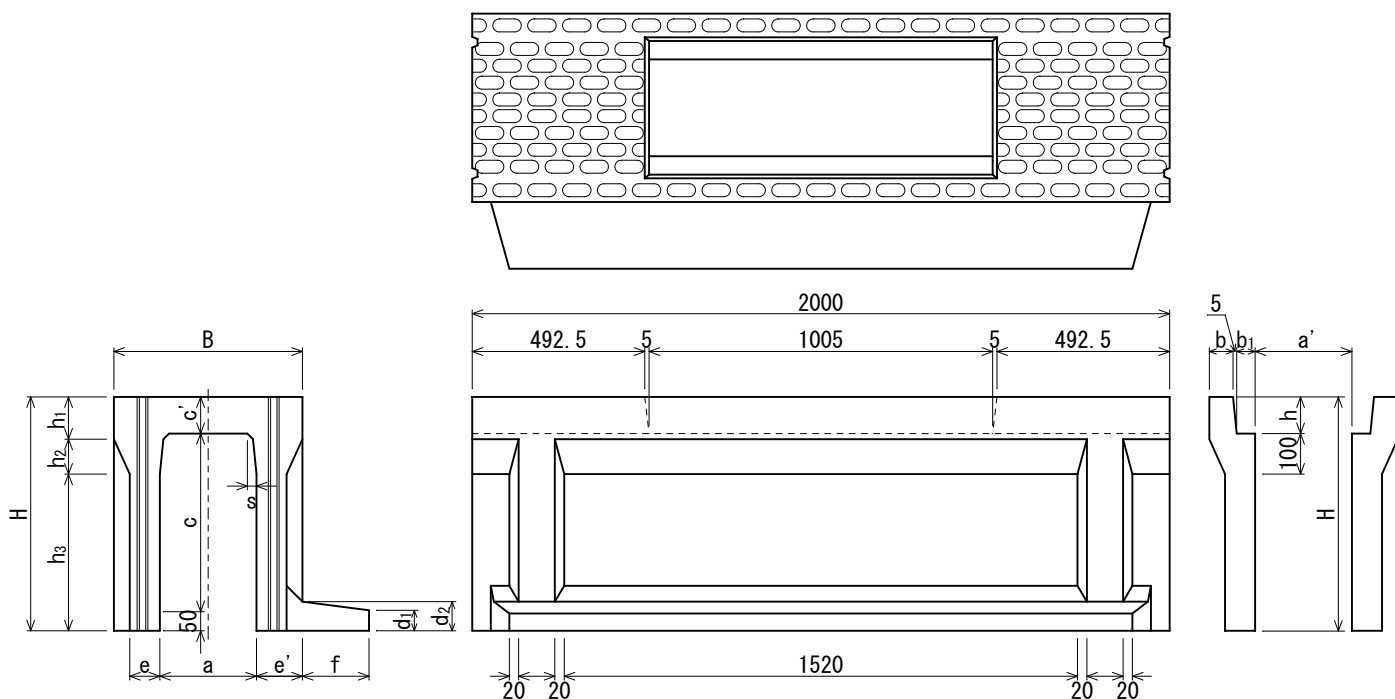

呼び名	寸法 (mm)																参考重量 (kg)															
	B	H	a	a'	c	c'	b	b <sub>1</sub>	e	e'	h	h <sub>1</sub>	h <sub>2</sub>	h <sub>3</sub>	f	d <sub>1</sub>		d <sub>2</sub>														
300×300	520	450	300	295	300	100	52.5	55	55	110	100	120	110	220	250	60	95	85	20													
300×400		550			400									320																		
300×500		650			500									420																		
300×600		750			600									550																		
300×700		850			700									650						400												
300×800		950			800									750																		
300×900		1050			900				870				500	105																		
300×1000		1150			1000				970																							
300×1100		1250			1100				1070																							
300×1200		1350			1200				600				75	110	1776																	
300×1300		1450			1300												1883															
300×1400		1550			1400												2025															
300×1500		1650			1500				700				70	2133																		
400×400		630			560				400				395	400	110		57.5			55	60	115	110	130	110	320	300	60	90	85	20	
400×500	660		500	420																												
400×600	760		600	520																												
400×700	860		700	640	350																											
400×800	960		800	740																												
400×900	1060		900	870	450																											
400×1000	1160		1000	970	100	1280																										
400×1100	1260		1100	1070	1400																											
400×1200	1360		1200	1170	1486																											
500×400	750		575	500	495	400	125	62.5		60	60	125		125		145		130	300		300				60	90	90		20			
500×500			675			500													400													
500×600			775			600													500													
500×700			875			700													620													1019
500×800			975			800													720													400
500×900		1075	900			820			1166																							
500×1000		1175	1000			950			1398																							
500×1100		1275	1100			1050			500		105		1485																			
500×1200		1375	1200			1150			1571																							
500×1300		1475	1300			1270			600						110		1803															
500×1400		1575	1400			1370			1898																							

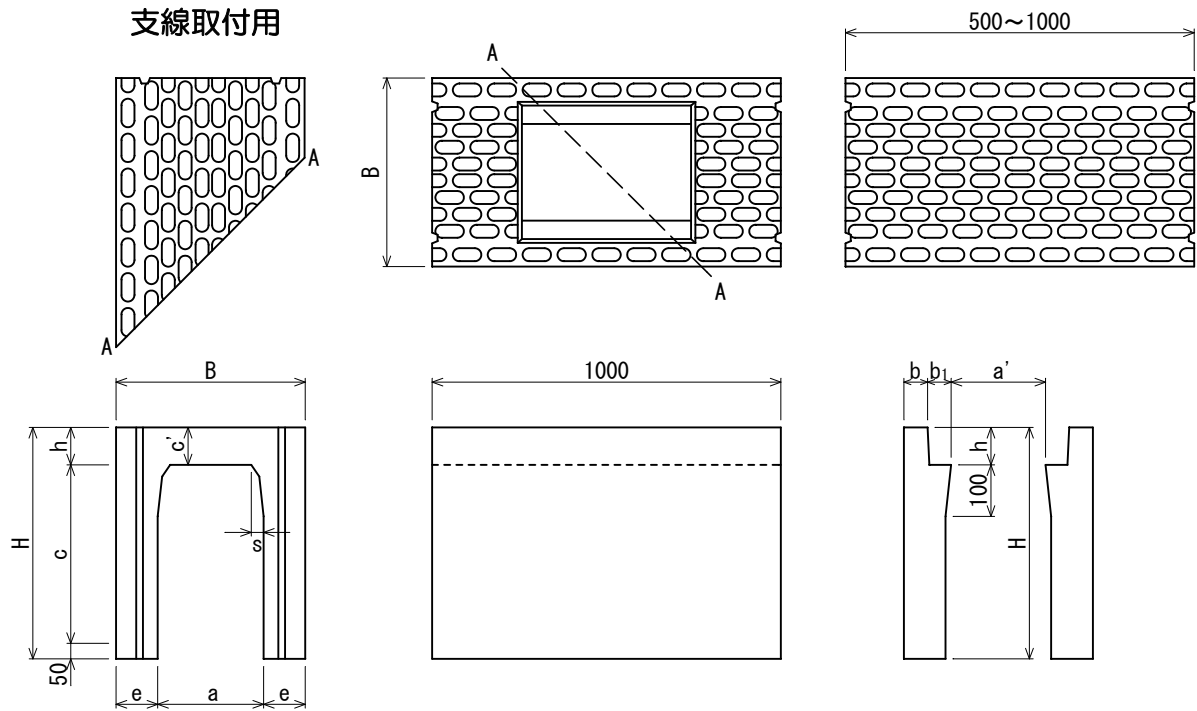

呼び名 (a×c)	寸法 (mm)							1m参考重量 (kg)	
	B	H	a	c'	e	h	s	蓋穴無し	蓋穴有り
300×300	520	450	300	100	110	100	30	310	260
300×400		550						363	313
300×500		650						416	366
300×600		750						468	419
300×700		850						521	471
300×800		950						573	524
300×900		1050						626	577
300×1000		1150						679	629
300×1100		1250						731	682
400×400		630						560	400
400×500	660		471	403					
400×600	760		526	458					
400×700	860		581	513					
400×800	960		636	568					
400×900	1060		691	624					
400×1000	1160		746	679					
400×1100	1260		801	734					
400×1200	1360		856	789					

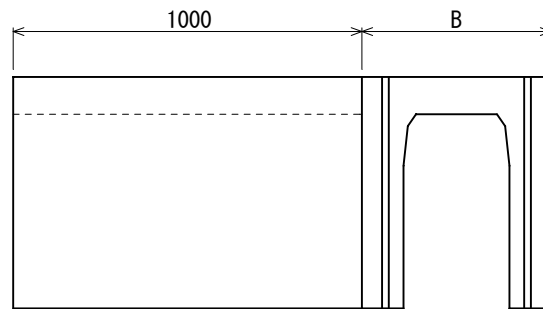
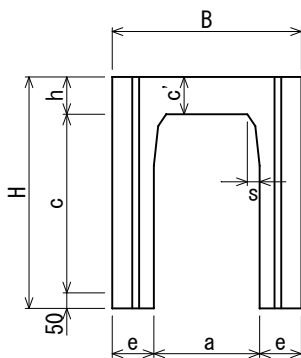
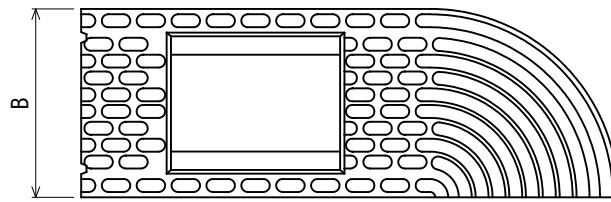

呼び名 ( a × c )	寸法 (mm)							参考重量 (kg)
	B	H	a	c'	e	h	s	
300 × 300	520	450	300	100	110	100	30	388
300 × 400		550						460
300 × 500		650						532
300 × 600		750						604
300 × 700		850						676
300 × 800		950						748
300 × 900		1050						820
300 × 1000		1150						892
300 × 1100		1250						964
400 × 400		630						560
400 × 500	660		635					
400 × 600	760		715					
400 × 700	860		795					
400 × 800	960		875					
400 × 900	1060		955					
400 × 1000	1160		1035					
400 × 1100	1260		1114					
400 × 1200	1360		1194					

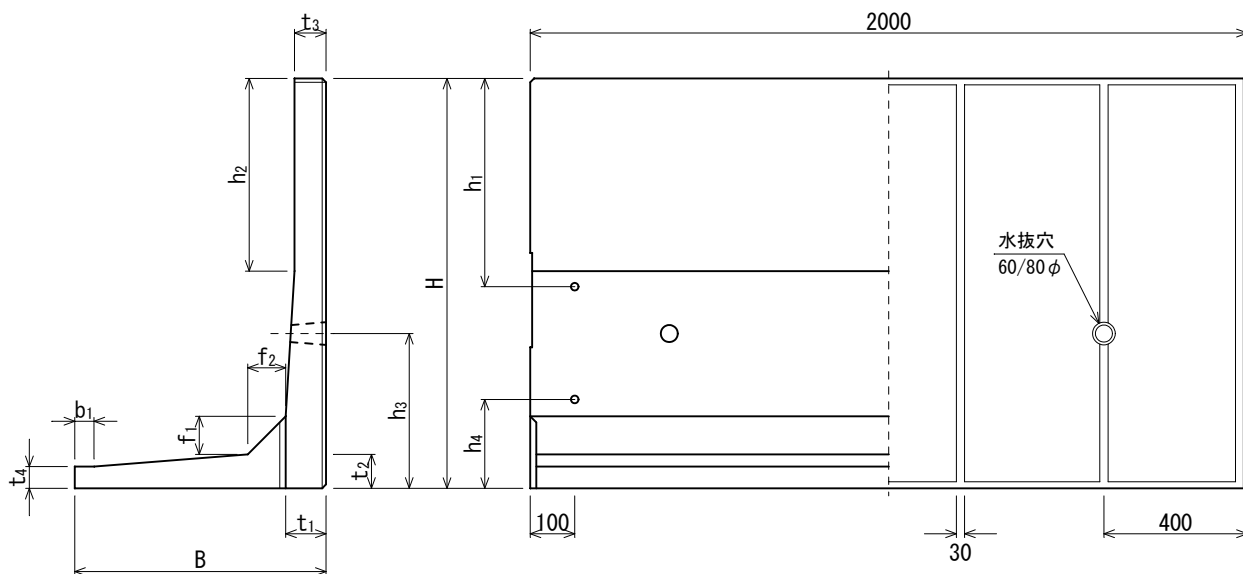

呼び名	寸法 (mm)													参考重量 (kg)
	H	B	t <sub>1</sub>	t <sub>2</sub>	t <sub>3</sub>	t <sub>4</sub>	f <sub>1</sub>	f <sub>2</sub>	h <sub>1</sub>	h <sub>2</sub>	h <sub>3</sub>	h <sub>4</sub>	b <sub>1</sub>	
SL- 500	500	400	80	80	80	60	80	80	250	200	220	—	—	319
SL- 600	600	450	80	80	80	60	80	80	350	300	220	—	50	372
SL- 700	700	550	80	80	80	60	100	100	250	300	280	—	—	456
SL- 800	800	600	80	80	80	60	100	100	350	400	280	—	50	508
SL- 900	900	650	90	90	80	60	100	100	350	300	280	—	—	597
SL-1000	1000	700	90	90	80	60	100	100	450	400	280	—	50	650
SL-1100	1100	750	105	105	80	60	120	120	350	300	500	—	—	787
SL-1200	1200	800	105	105	80	60	120	120	450	400	500	—	50	840
SL-1300	1300	900	115	115	80	80	120	120	250	200	500	—	—	1023
SL-1400	1400	950	115	115	80	80	120	120	350	300	500	—	50	1081
SL-1500	1500	1000	115	115	80	80	120	120	450	400	500	—	100	1139
SL-1600	1600	1100	140	140	100	100	140	140	250	200	600	330	—	1543
SL-1700	1700	1150	140	140	100	100	140	140	350	300	600	330	50	1615
SL-1800	1800	1200	140	140	100	100	140	140	450	400	600	330	100	1692
SL-1900	1900	1350	150	150	100	100	150	150	350	300	700	350	—	1932
SL-2000	2000	1350	150	150	100	100	150	150	450	400	700	350	—	1980
SL-2100	2100	1500	180	210	100	130	180	180	170	0	830	440	—	2731
SL-2200	2200	1500	180	210	100	130	180	180	120	70	830	440	—	2786
SL-2300	2300	1500	180	210	100	130	180	180	220	170	830	440	—	2835
SL-2400	2400	1700	180	210	100	130	180	180	320	270	830	440	200	3012
SL-2500	2500	1700	180	210	100	130	180	180	420	370	830	440	200	3061
SL-2600	2600	1850	220	220	100	100	200	200	200	100	1000	470	100	3466
SL-2700	2700	1850	220	220	100	100	200	200	150	200	1000	470	100	3514
SL-2800	2800	1850	220	220	100	100	200	200	250	300	1000	470	100	3562
SL-2900	2900	2000	220	220	100	100	200	200	350	400	1000	470	250	3682
SL-3000	3000	2000	220	220	100	100	200	200	450	500	1000	470	250	3730

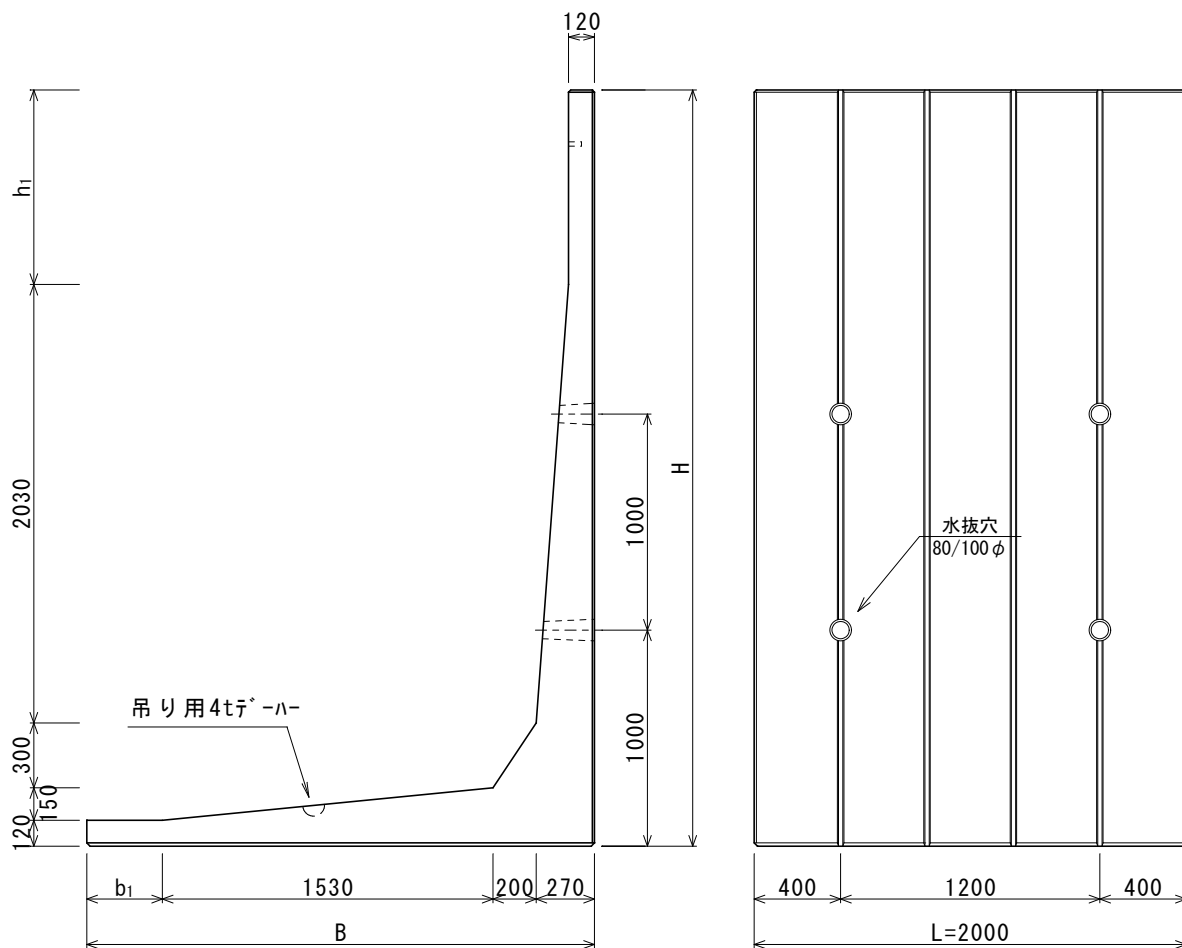

呼び名	寸 法 (mm)				製品重量 (kg)
	h	B	b <sub>1</sub>	h <sub>1</sub>	
SL-3100	3100	2200	200	500	4877
SL-3200	3200	2200	200	600	4935
SL-3300	3300	2200	200	700	4993
SL-3400	3400	2350	350	800	5137
SL-3500	3500	2350	350	900	5194
SL-3600	3600	2500	500	1000	5338
SL-3700	3700	2500	500	1100	5396
SL-3800	3800	2650	650	1200	5540
SL-3900	3900	2650	650	1300	5597
SL-4000	4000	2650	650	1400	5655



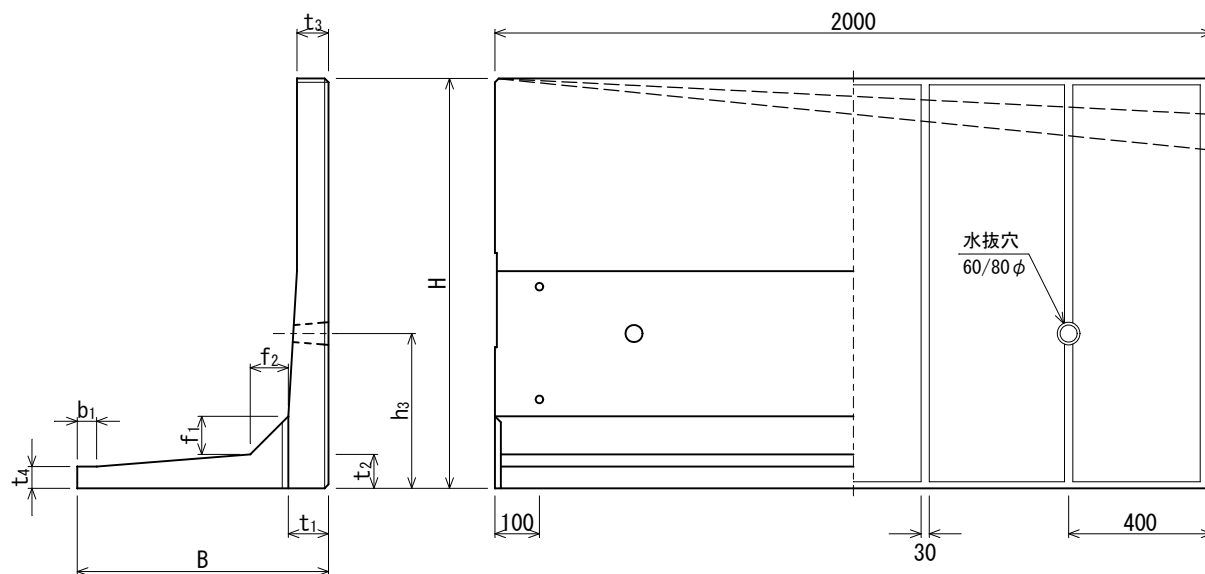

呼び名	寸 法 (mm)								参考重量 (kg)		
	全高さ H	底板 B	t <sub>1</sub>	t <sub>2</sub>	t <sub>3</sub>	t <sub>4</sub>	f <sub>1</sub>	f <sub>2</sub>	0%	5%	10%
SL-S 600	501~ 600	450	80	80	80	60	80	80	372	353	334
SL-S 700	601~ 700	550	80	80	80	60	100	100	456	437	418
SL-S 800	701~ 800	600	80	80	80	60	100	100	508	489	470
SL-S 900	801~ 900	650	90	90	80	60	100	100	597	578	559
SL-S1000	901~1000	700	90	90	80	60	100	100	650	631	612
SL-S1100	1001~1100	750	105	105	80	60	120	120	787	768	749
SL-S1200	1101~1200	800	105	105	80	60	120	120	840	821	802
SL-S1300	1201~1300	900	115	115	80	80	120	120	1023	1004	985
SL-S1400	1301~1400	950	115	115	80	80	120	120	1081	1062	1043
SL-S1500	1401~1500	1000	115	115	80	80	120	120	1139	1120	1101
SL-S1600	1501~1600	1100	140	140	100	100	140	140	1543	1519	1495
SL-S1700	1601~1700	1150	140	140	100	100	140	140	1615	1591	1567
SL-S1800	1701~1800	1200	140	140	100	100	140	140	1692	1668	1644
SL-S1900	1801~1900	1350	150	150	100	100	150	150	1932	1908	1884
SL-S2000	1901~2000	1350	150	150	100	100	150	150	1980	1956	1932
SL-S2100	2001~2100	1500	180	210	100	130	180	180	2731	2707	2683
SL-S2200	2101~2200	1500	180	210	100	130	180	180	2786	2762	2738
SL-S2300	2201~2300	1500	180	210	100	130	180	180	2835	2811	2787
SL-S2400	2301~2400	1700	180	210	100	130	180	180	3012	2988	2964
SL-S2500	2401~2500	1700	180	210	100	130	180	180	3061	3037	3013
SL-S2600	2501~2600	1850	220	220	100	100	200	200	3466	3442	3418
SL-S2700	2601~2700	1850	220	220	100	100	200	200	3514	3490	3466
SL-S2800	2701~2800	1850	220	220	100	100	200	200	3562	3538	3514
SL-S2900	2801~2900	2000	220	220	100	100	200	200	3682	3658	3634
SL-S3000	2901~3000	2000	220	220	100	100	200	200	3730	3706	3682

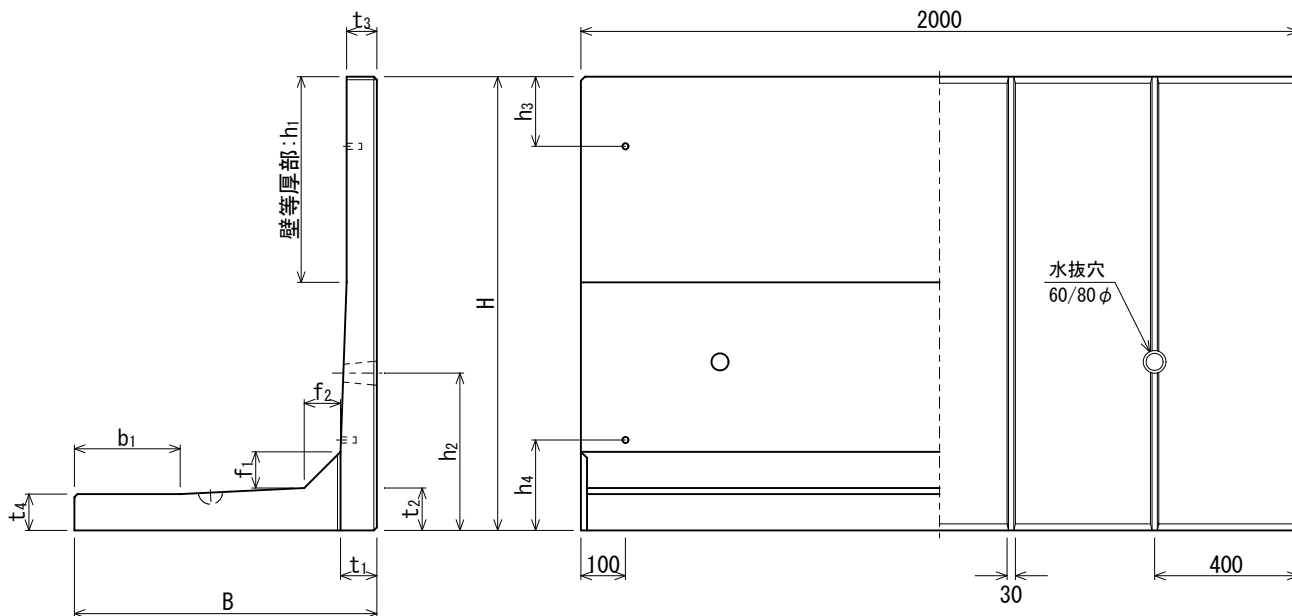

呼び名	寸法 (mm)													参考重量 (kg)
	H	B	t <sub>1</sub>	t <sub>2</sub>	t <sub>3</sub>	t <sub>4</sub>	f <sub>1</sub>	f <sub>2</sub>	h <sub>1</sub>	h <sub>2</sub>	h <sub>3</sub>	h <sub>4</sub>	b <sub>1</sub>	
SL(新) - 800	800	800	120	120	100	120	120	120	—	520	130	—	150	911
SL(新) - 900	900	850	120	120	100	120	120	120	80	520	230	—	200	990
SL(新) - 1000	1000	900	120	120	100	120	120	120	180	520	130	—	250	1069
SL(新) - 1100	1100	950	120	120	100	120	120	120	280	520	230	—	300	1147
SL(新) - 1200	1200	1000	120	120	100	120	120	120	380	520	130	—	350	1225
SL(新) - 1300	1300	1100	120	120	100	120	120	120	480	520	230	—	450	1333
SL(新) - 1400	1400	1150	120	120	100	120	120	120	580	520	130	—	500	1412
SL(新) - 1500	1500	1200	120	120	100	120	120	120	680	520	230	—	550	1492
SL(新) - 1600	1600	1250	140	170	100	130	140	140	170	630	220	360	150	1817
SL(新) - 1700	1700	1300	140	170	100	130	140	140	270	630	320	360	200	1898
SL(新) - 1800	1800	1350	140	170	100	130	140	140	370	630	420	360	250	1979
SL(新) - 1900	1900	1450	150	180	100	130	150	150	270	730	320	380	100	2220
SL(新) - 2000	2000	1500	150	180	100	130	150	150	370	730	420	380	150	2301
SL(新) - 2100	2100	1550	180	210	100	130	180	180	—	830	170	440	50	2763
SL(新) - 2200	2200	1600	180	210	100	130	180	180	70	830	120	440	100	2850
SL(新) - 2300	2300	1650	180	210	100	130	180	180	170	830	220	440	150	2931
SL(新) - 2400	2400	1750	180	210	100	130	180	180	270	830	320	440	250	3043
SL(新) - 2500	2500	1825	180	210	100	130	180	180	370	830	420	440	325	3140

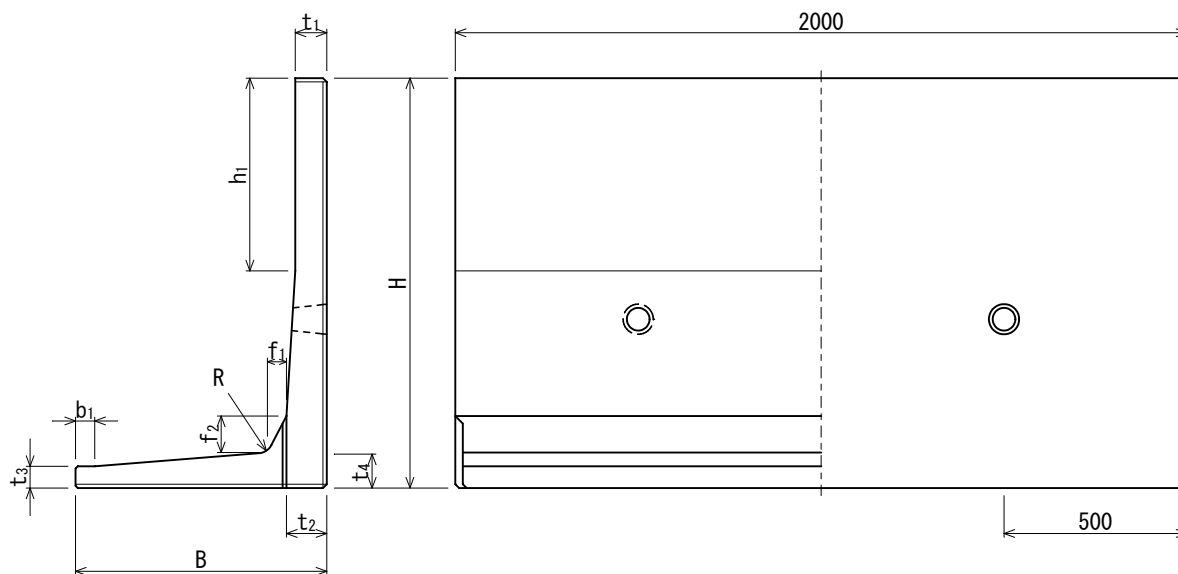

呼び名	寸法 (mm)											参考重量 (kg)
	H	B	t <sub>1</sub>	t <sub>2</sub>	t <sub>3</sub>	t <sub>4</sub>	f <sub>1</sub>	f <sub>2</sub>	h <sub>1</sub>	b <sub>1</sub>	R	
TSL 800	800	650	120	120	100	130	100	100	570	100	100	794
TSL 900	900	700	120	120	100	130	100	100	670	150	100	877
TSL 1000	1000	750	120	120	100	130	100	100	770	200	100	960
TSL 1100	1100	800	120	120	100	130	100	100	870	250	100	1043
TSL 1200	1200	850	120	120	100	130	100	100	970	300	100	1127
TSL 1300	1300	900	120	120	100	150	150	300	850	200	200	1346
TSL 1400	1400	1000	120	120	100	150	150	300	950	300	200	1454
TSL 1500	1500	1050	120	120	100	150	150	300	1050	350	200	1537
TSL 1600	1600	1100	120	120	100	150	150	300	1150	400	200	1621
TSL 1700	1700	1150	120	120	100	150	150	300	1250	450	200	1704
TSL 1800	1800	1200	120	120	100	150	150	300	1350	500	200	1787
TSL 1900	1900	1250	120	180	120	180	200	400	600	250	250	2369
TSL 2000	2000	1300	120	180	120	180	200	400	700	300	250	2457
TSL 2100	2100	1350	120	180	120	180	200	400	800	350	250	2545
TSL 2200	2200	1425	120	180	120	180	200	400	900	425	250	2648
TSL 2300	2300	1525	120	180	120	180	200	400	1000	500	250	2751
TSL 2400	2400	1550	120	180	120	180	200	400	1100	550	250	2839
TSL 2500	2500	1650	120	200	120	200	200	400	600	150	250	3303
TSL 2600	2600	1700	120	200	120	200	200	400	700	200	250	3391
TSL 2700	2700	1750	120	200	120	200	200	400	800	250	250	3479
TSL 2800	2800	1800	120	200	120	200	200	400	900	300	250	3567
TSL 2900	2900	1900	120	200	120	200	200	400	1000	400	250	3685
TSL 3000	3000	1975	120	200	120	200	200	400	1100	500	250	3802

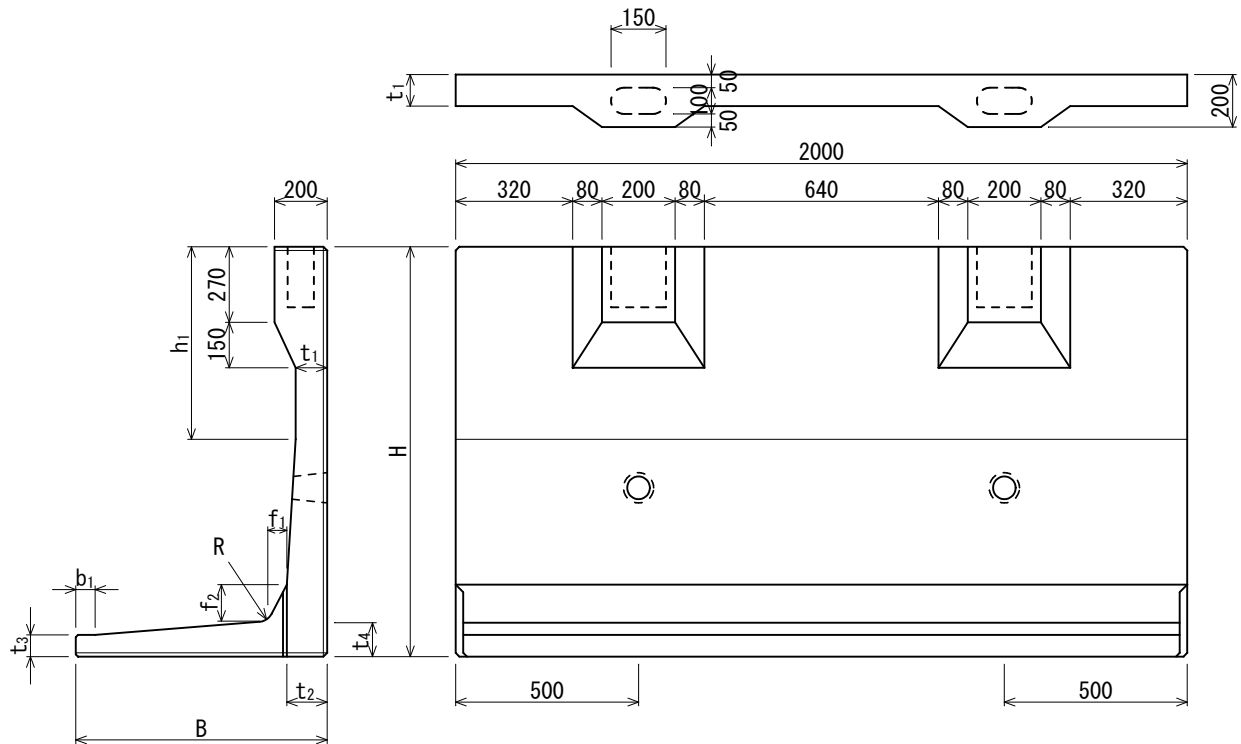

呼び名	寸 法 (mm)											参考重量 (kg)
	H	B	t <sub>1</sub>	t <sub>2</sub>	t <sub>3</sub>	t <sub>4</sub>	f <sub>1</sub>	f <sub>2</sub>	h <sub>1</sub>	b <sub>1</sub>	R	
TSL- 800F	800	650	120	120	100	130	100	100	570	100	100	834
TSL- 900F	900	700	120	120	100	130	100	100	670	150	100	917
TSL-1000F	1000	750	120	120	100	130	100	100	770	200	100	1000
TSL-1100F	1100	800	120	120	100	130	100	100	870	250	100	1084
TSL-1200F	1200	850	120	120	100	130	100	100	970	300	100	1167
TSL-1300F	1300	900	120	120	100	150	150	300	850	200	200	1386
TSL-1400F	1400	1000	120	120	100	150	150	300	950	250	200	1494
TSL-1500F	1500	1050	120	120	100	150	150	300	1050	300	200	1577
TSL-1600F	1600	1100	120	120	100	150	150	300	1150	350	200	1661
TSL-1700F	1700	1150	120	120	100	150	150	300	1250	400	200	1744
TSL-1800F	1800	1200	120	120	100	150	150	300	1350	450	200	1827
TSL-1900F	1900	1250	120	180	120	180	200	400	600	250	250	2409
TSL-2000F	2000	1300	120	180	120	180	200	400	700	300	250	2497
TSL-2100F	2100	1350	120	180	120	180	200	400	800	350	250	2585
TSL-2200F	2200	1425	120	180	120	180	200	400	900	400	250	2688
TSL-2300F	2300	1525	120	180	120	180	200	400	1000	475	250	2791
TSL-2400F	2400	1550	120	180	120	180	200	400	1100	550	250	2879
TSL-2500F	2500	1650	120	200	120	200	200	400	600	200	250	3343
TSL-2600F	2600	1700	120	200	120	200	200	400	700	275	250	3431
TSL-2700F	2700	1750	120	200	120	200	200	400	800	325	250	3519
TSL-2800F	2800	1800	120	200	120	200	200	400	900	375	250	3607
TSL-2900F	2900	1900	120	200	120	200	200	400	1000	450	250	3725
TSL-3000F	3000	1975	120	200	120	200	200	400	1100	600	250	3842

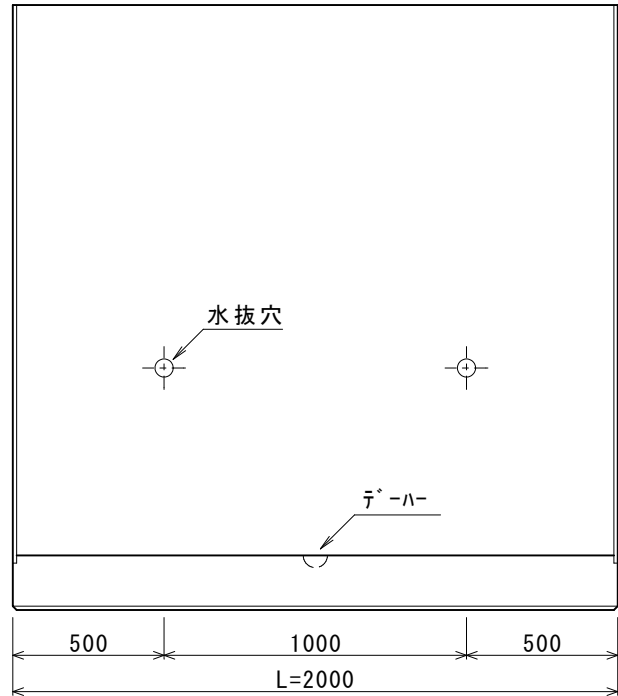
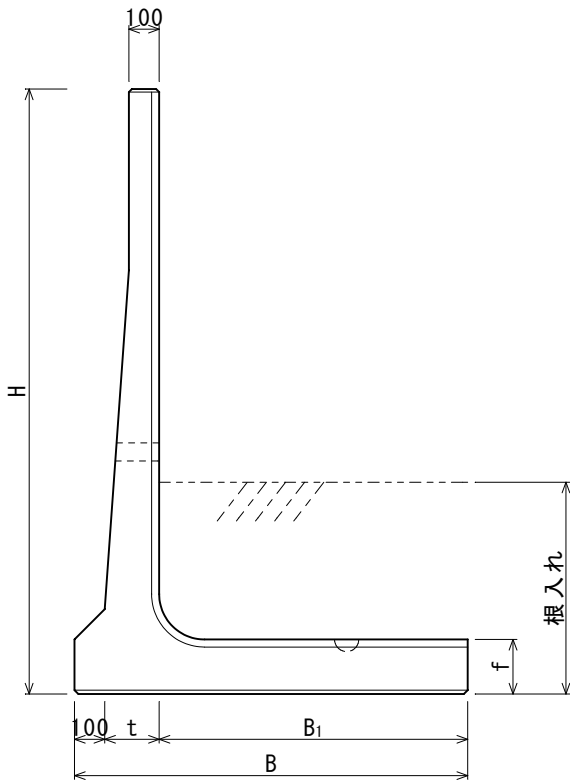

呼び名	寸法 (mm)					必要根入れ (mm)		製品重量 (kg)
	H	B	B <sub>1</sub>	f	t	Q=5KN/m <sup>2</sup>	Q=10KN/m <sup>2</sup>	
SLR- 800	800	500	270	130	130	250	350	709
SLR- 900	900	600	370	130	130	250	400	819
SLR-1000	1000	650	420	130	130	300	400	899
SLR-1100	1100	700	470	130	130	300	450	978
SLR-1200	1200	750	520	130	130	350	500	1067
SLR-1300	1300	850	620	130	130	400	500	1167
SLR-1400	1400	900	670	130	130	400	550	1247
SLR-1500	1500	950	720	130	130	450	550	1326
SLR-1600	1600	1050	820	130	130	450	600	1436
SLR-1700	1700	1100	820	180	180	450	600	1981
SLR-1800	1800	1150	870	180	180	500	650	2072
SLR-1900	1900	1250	970	180	180	550	650	2206
SLR-2000	2000	1300	1020	180	180	550	700	2297
SLR-2100	2100	1350	1070	180	180	600	700	2389
SLR-2200	2200	1400	1120	180	180	600	750	2480
SLR-2300	2300	1450	1170	180	180	650	800	2571
SLR-2400	2400	1550	1270	180	180	700	800	2705
SLR-2500	2500	1600	1320	180	180	700	850	2797

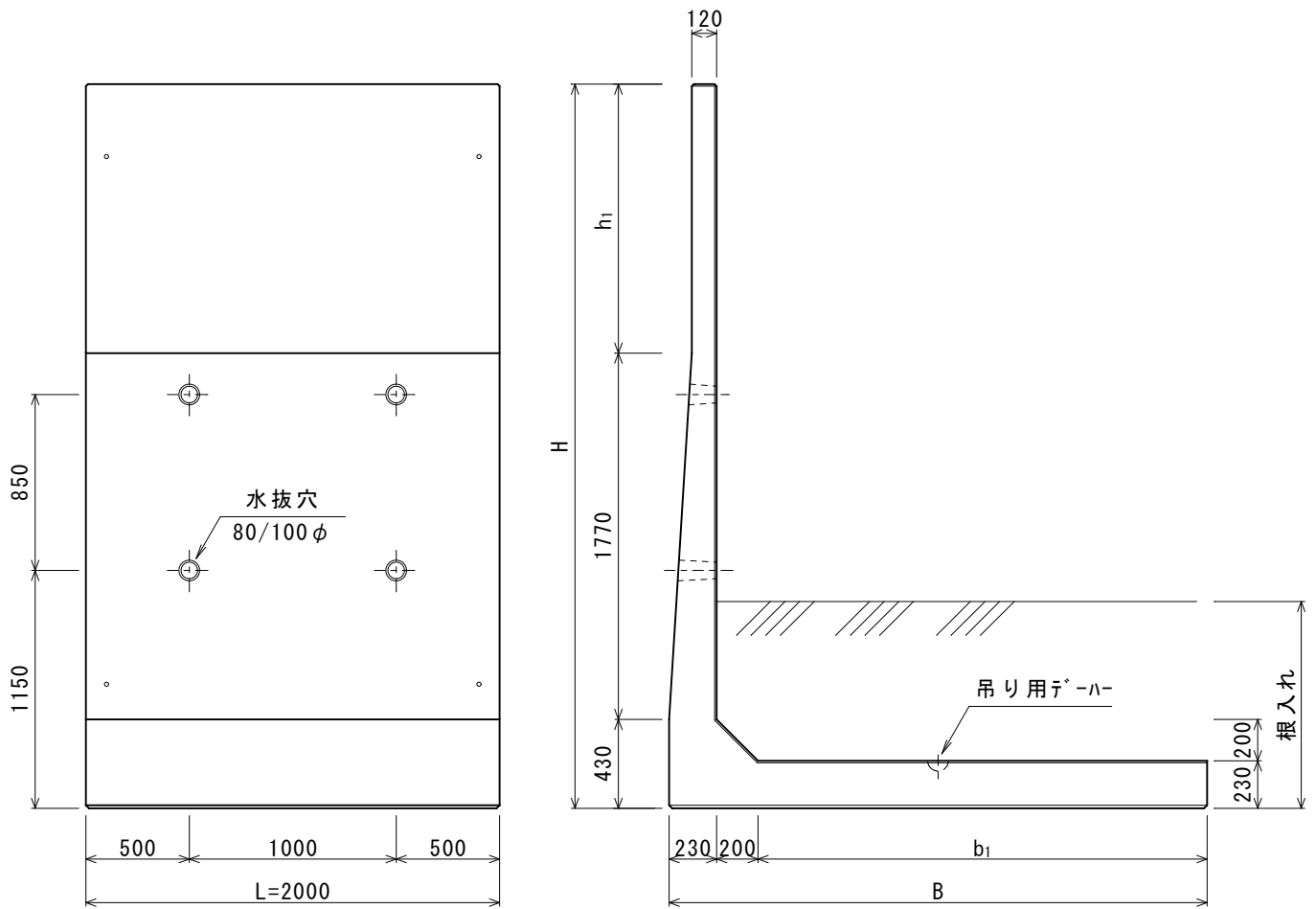

呼び名	寸法 (mm)				根入れ (mm)		製品重量 (kg)
	H	B	b <sub>1</sub>	h <sub>1</sub>	Q=5KN/m <sup>2</sup>	Q=10KN/m <sup>2</sup>	
SLR-2600	2600	1700	1270	400	750	850	3911
SLR-2700	2700	1800	1370	500	750	900	4079
SLR-2800	2800	1900	1470	600	800	900	4247
SLR-2900	2900	2000	1570	700	800	950	4415
SLR-3000	3000	2100	1670	800	850	950	4583
SLR-3100	3100	2200	1770	900	850	1000	4751
SLR-3200	3200	2300	1870	1000	900	1000	4919
SLR-3300	3300	2400	1970	1100	900	1000	5087
SLR-3400	3400	2500	2070	1200	950	1050	5255
SLR-3500	3500	2600	2170	1300	950	1050	5423

# BOXカルバート (T-25)

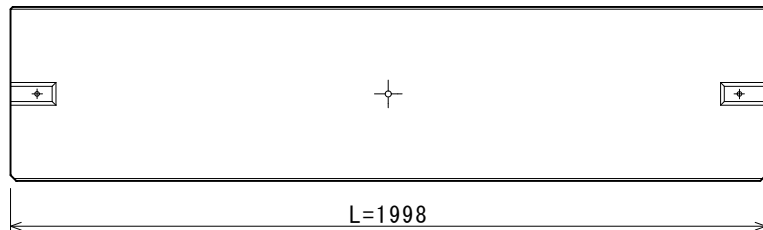
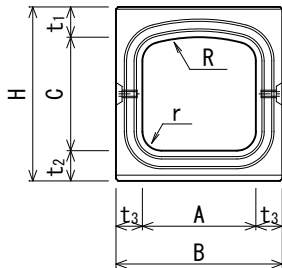
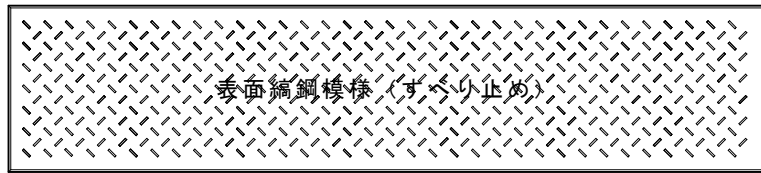

呼び名 A × C	寸 法 (mm)									参考重量 (kg)
	A	B	C	t <sub>1</sub>	t <sub>2</sub>	t <sub>3</sub>	H	R	r	
250 × 250	250	370	250	70	70	60	390	375	50	419
300 × 300	300	440	300	80	80	70	460	450	50	574
300 × 400	300	440	400	80	80	70	560	500	50	642
300 × 500	300	440	500	80	80	70	660	500	50	710
400 × 250	400	560	250	100	100	80	450	600	50	817
400 × 400	400	560	400	95	95	80	590	600	50	874
400 × 500	400	560	500	95	95	80	690	600	50	952
400 × 600	400	560	600	95	95	80	790	600	50	1030
450 × 450	450	610	450	95	95	80	640	675	50	969
500 × 500	500	660	500	100	100	80	700	750	100	1113
600 × 600	600	800	600	120	120	100	840	900	100	1626
700 × 700	700	900	700	120	120	100	940	1050	100	1868
800 × 800	800	1000	800	130	130	100	1060	1200	100	2269
900 × 900	900	1100	900	130	140	100	1170	1350	100	2528
1000 × 1000	1000	1200	1000	130	140	100	1270	1500	100	2799

## BOX用敷板

基礎コンクリートを現場打ち施工する代わりに、BOX用敷板を使用することで、掘削からボックスカルバート等の据え付けまでが短時間で行え、大幅に工期短縮が図れます。

寸 法 (mm)			参考重量 (kg)
B	T	L	
400	100	2000	200
540	100	2000	264
650	100	2000	318
760	100	2000	372
1860	100	1000	456



- \* 敷板のサイズは相談に応じます。
- \* 吊り具は1tカブラーとなります。

# BOXカルバート (T-25)

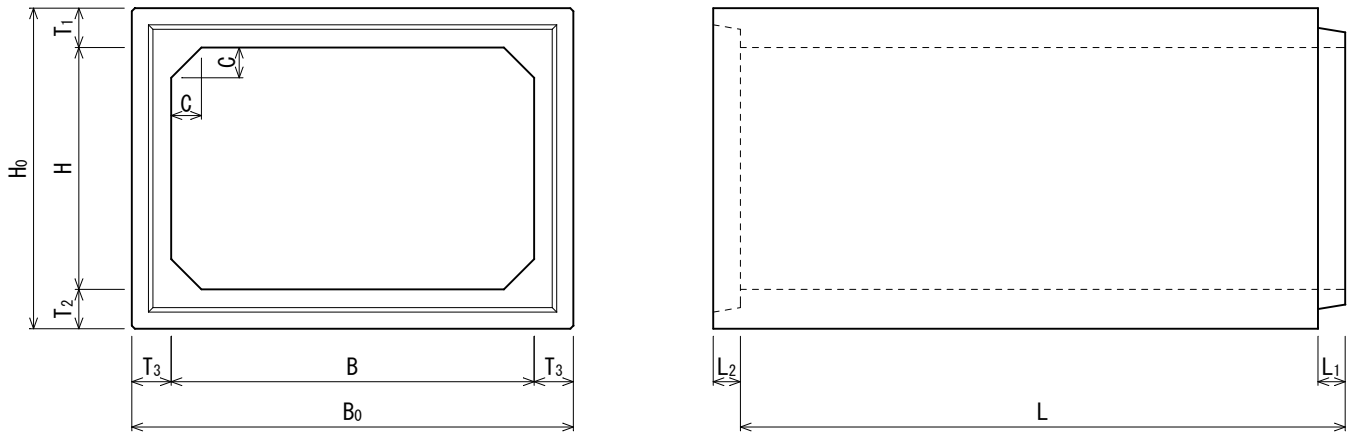

呼び名 B × H	寸 法 (mm)											参考重量 (kg)
	B	B <sub>0</sub>	H	H <sub>0</sub>	T <sub>1</sub>	T <sub>2</sub>	T <sub>3</sub>	C	L	L <sub>1</sub>	L <sub>2</sub>	
600 × 500	600	860	500	760	130	130	130	100	2000	60	40	1870
600 × 600	600	860	600	860	130	130	130	100	2000	60	40	2000
600 × 800	600	860	800	1060	130	130	130	100	2000	60	40	2260
600 × 1000	600	860	1000	1260	130	130	130	100	2000	60	40	2520
700 × 700	700	960	700	960	130	130	130	100	2000	60	40	2260
800 × 600	800	1060	600	860	130	130	130	100	2000	60	40	2260
800 × 700	800	1060	700	960	130	130	130	100	2000	60	40	2390
800 × 800	800	1060	800	1060	130	130	130	100	2000	60	40	2520
900 × 900	900	1160	900	1160	130	130	130	100	2000	60	40	2780
1000 × 1000	1000	1260	1000	1260	130	130	130	150	2000	60	60	3160
1100 × 1100	1100	1360	1100	1360	130	130	130	150	2000	60	60	3420
1200 × 600	1200	1460	600	860	130	130	130	150	2000	60	60	2940
1200 × 900	1200	1460	900	1160	130	130	130	150	2000	60	60	3330
1200 × 1200	1200	1460	1200	1460	130	130	130	150	2000	60	60	3680
1200 × 1500	1200	1460	1500	1760	130	130	130	150	2000	60	60	4070
1300 × 1300	1300	1560	1300	1580	140	140	130	150	2000	60	60	4100
1400 × 1100	1400	1660	1100	1400	150	150	130	150	2000	60	60	4150
1400 × 1400	1400	1660	1400	1700	150	150	130	150	2000	60	60	4540
1500 × 1000	1500	1780	1000	1320	160	160	140	150	2000	60	60	4470
1500 × 1300	1500	1780	1300	1620	160	160	140	150	2000	60	60	4890
1500 × 1500	1500	1780	1500	1820	160	160	140	150	2000	60	60	5170
1800 × 1800	1800	2100	1800	2140	170	170	150	150	2000	80	80	6500
2000 × 1500	2000	2320	1500	1860	180	180	160	200	2000	80	80	6980
2000 × 1600	2000	2320	1600	1960	180	180	160	200	2000	80	80	7140
2000 × 1800	2000	2320	1800	2160	180	180	160	200	2000	80	80	7460
2000 × 2000	2000	2320	2000	2360	180	180	160	200	2000	80	80	7780





荷重条件別標準寸法表

	寸法 (mm)		参考重量 (kg)		寸法 (mm)		参考重量 (kg)
	W	T			W	T	
歩道仕様 T-2仕様	1000	100	245	T-14仕様	1000	140	343
	1500	120	441		1500	160	588
	2000	140	686		2000	180	882
	2500	160	980		2500	200	1225
	3000	180	1323		3000	220	1617
	3500	200	1715		3500	240	2058
	4000	220	2156		4000	260	2548
	4500	240	2646		4500	280	3087
	5000	260	3185		5000	300	3675
T-6仕様	1000	120	294	T-25仕様	1000	160	392
	1500	140	515		1500	190	698
	2000	160	784		2000	220	1078
	2500	180	1103		2500	250	1531
	3000	200	1470		3000	270	1985
	3500	220	1887		3500	290	2487
	4000	240	2352		4000	310	3038
	4500	260	2867		4500	330	3638
	5000	280	3430		5000	350	4288

\* 個々の使用条件に応じて詳細仕様は検討いたします。

\* 床版幅 (W = 5000 以下) はご要望の寸法で製造可能です。

検討は、担当営業にお申し付け下さい



## 杭

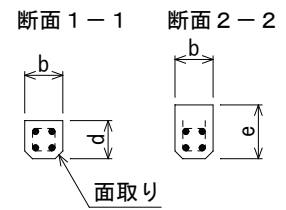
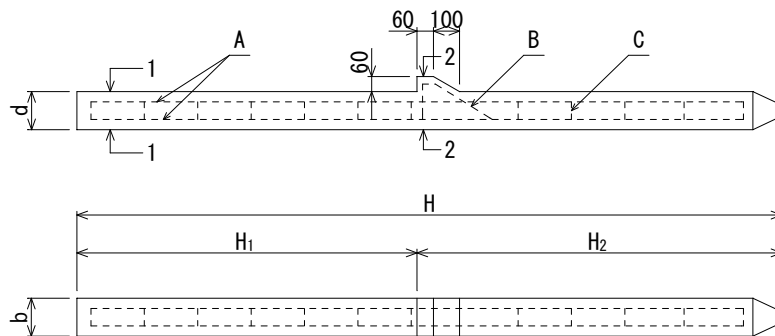

種類	寸法 (mm)						配筋						参考重量 (kg)
	H	H <sub>1</sub>	H <sub>2</sub>	b	d	e	A		B		C		
							径	本数	径	本数	径	本数	
1-70	700	300	400	120	120	180	D6	4	φ6	2	φ4	5	23
1-100	1000	300	700	120	120	180	D6	4	φ6	2	φ4	5	35
1-130	1300	600	700	120	120	180	D6	4	φ6	2	φ4	7	44
1-150	1500	600	900	120	120	180	D6	4	φ6	2	φ4	8	51
1-190	1900	900	1000	120	120	180	D10	4	φ6	2	φ6	9	66
1-200	2000	900	1100	120	120	180	D10	4	φ6	2	φ6	9	69
1-220	2200	900	1300	120	120	180	D10	4	φ6	2	φ6	10	75
1-250	2500	1200	1300	120	120	180	D10	4	φ6	2	φ6	11	86

## 柵板

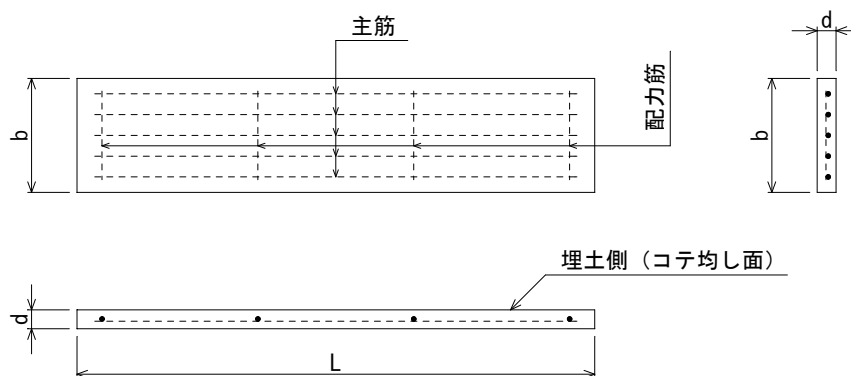

種類	寸法 (mm)			主鉄筋		配力鉄筋		参考重量 (kg)
	L	b	d	径	本	径	本	
1種	980	298	60	φ6	5	φ6	4	42
2種	1480	298	60	φ6	5	φ6	5	64

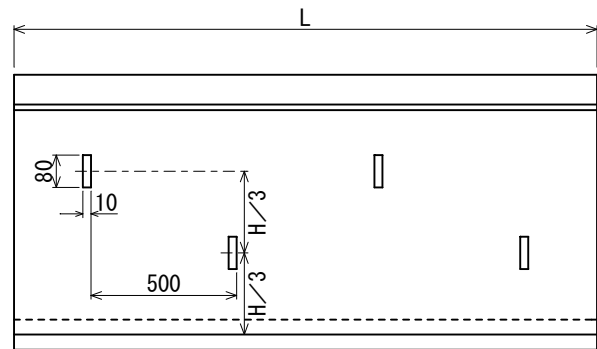
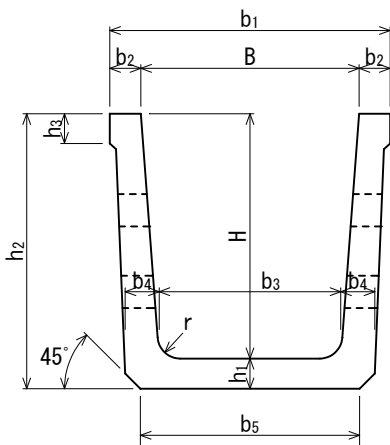
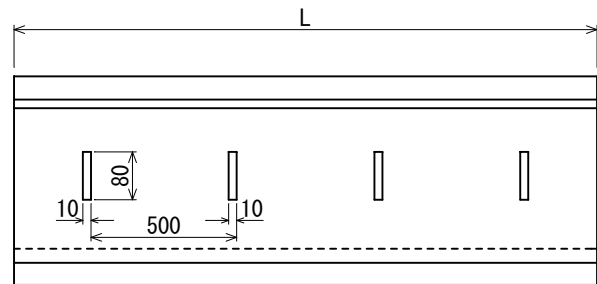
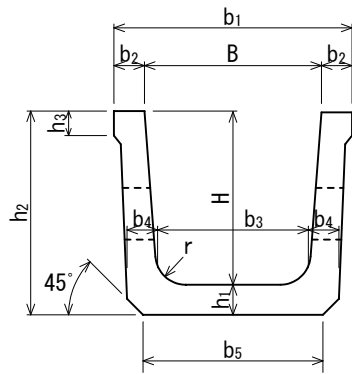

呼び名	寸法 (mm)												参考重量 (kg)
	B	H	b <sub>1</sub>	b <sub>2</sub>	b <sub>3</sub>	b <sub>4</sub>	b <sub>5</sub>	h <sub>1</sub>	h <sub>2</sub>	h <sub>3</sub>	r	L	
303	300	300	400	50	260	50	300	50	350	40	50	2000	212
404	400	400	500	50	360	50	400	50	450	40	50	2000	274
450	450	450	600	75	400	70	430	70	520	65	50	2000	444
505	500	500	620	60	450	55	500	55	555	40	70	2000	373
606	600	600	730	65	540	60	600	60	660	40	70	2000	474
608	600	800	750	75	540	90	600	90	890	70	70	2000	891
706	700	600	850	75	640	70	700	70	670	70	70	2000	611
707	700	700	850	75	640	80	700	80	780	70	70	2000	762
806	800	600	980	90	740	80	800	80	680	70	70	2000	753
808	800	800	950	75	700	90	800	90	890	100	70	2000	921
909	900	900	1080	90	800	95	900	95	995	100	70	2000	1110
1006	1000	600	1150	75	940	75	1000	80	680	100	70	2000	798
1008	1000	800	1200	100	900	90	1000	90	890	100	70	2000	1043
1009	1000	900	1210	105	900	95	1000	95	995	100	70	2000	1177
1010	1000	1000	1220	110	900	100	1000	100	1100	110	70	2000	1327
1012	1000	1200	1220	110	900	115	1000	115	1315	110	70	2000	1708
1208	1200	800	1400	100	1100	90	1200	90	890	100	70	2000	1129
1209	1200	900	1410	105	1120	95	1200	95	995	100	70	2000	1268
1210	1200	1000	1420	110	1120	100	1200	100	1100	100	70	2000	1417
1212	1200	1200	1420	110	1100	115	1200	115	1315	110	70	2000	1818
1412	1400	1200	1620	110	1320	115	1400	115	1315	110	70	2000	1976

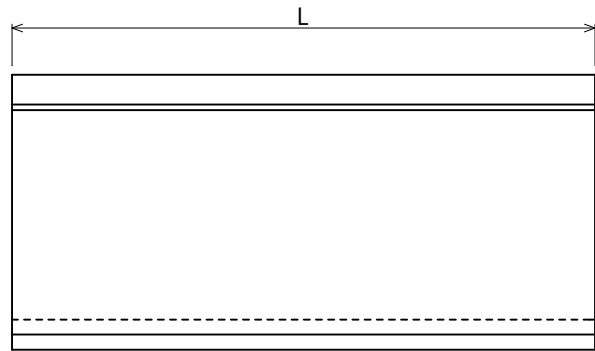
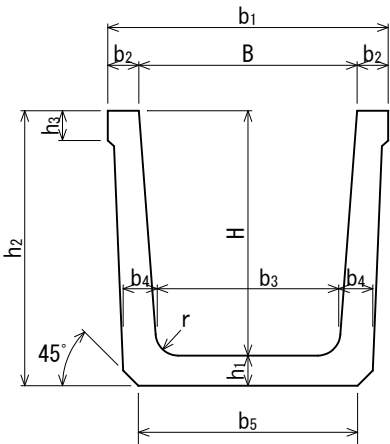
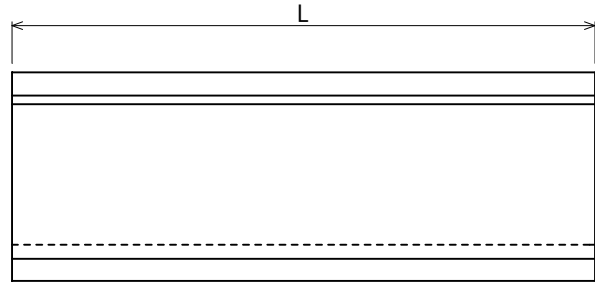
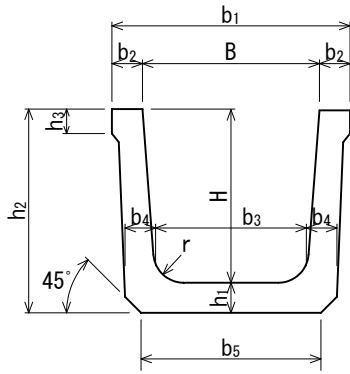

呼び名	寸 法 (mm)											参考重量 (kg)	
	B	H	b <sub>1</sub>	b <sub>2</sub>	b <sub>3</sub>	b <sub>4</sub>	b <sub>5</sub>	h <sub>1</sub>	h <sub>2</sub>	h <sub>3</sub>	r		L
303	300	300	430	65	260	60	300	60	360	50	50	2000	266
404	400	400	550	75	360	65	400	65	465	55	50	2000	380
450	450	450	600	75	400	70	430	70	520	65	50	2000	444
505	500	500	670	85	450	70	490	70	570	65	70	2000	505
606	600	600	780	90	540	80	600	80	680	70	70	2000	676
608	600	800	750	75	540	90	600	90	890	70	70	2000	891
706	700	600	850	75	640	70	700	70	670	70	70	2000	611
707	700	700	850	75	640	80	700	80	780	70	70	2000	762
806	800	600	980	90	740	80	800	80	680	70	70	2000	753
808	800	800	950	75	700	90	800	90	890	100	70	2000	921
909	900	900	1080	90	800	95	900	95	995	100	70	2000	1110
1006	1000	600	1150	75	940	75	1000	75	675	100	70	2000	772
1008	1000	800	1200	100	900	90	1000	90	890	100	70	2000	1043
1009	1000	900	1210	105	900	95	1000	95	995	100	70	2000	1177
1010	1000	1000	1220	110	900	100	1000	100	1100	110	70	2000	1327
1012	1000	1200	1220	110	900	115	1000	115	1315	110	70	2000	1708
1208	1200	800	1400	100	1100	90	1200	90	890	100	70	2000	1129
1209	1200	900	1410	105	1120	95	1200	95	995	100	70	2000	1268
1210	1200	1000	1420	110	1120	100	1200	100	1100	100	70	2000	1417
1212	1200	1200	1420	110	1100	115	1200	115	1315	110	70	2000	1818
1412	1400	1200	1620	110	1320	115	1400	115	1315	110	70	2000	1976

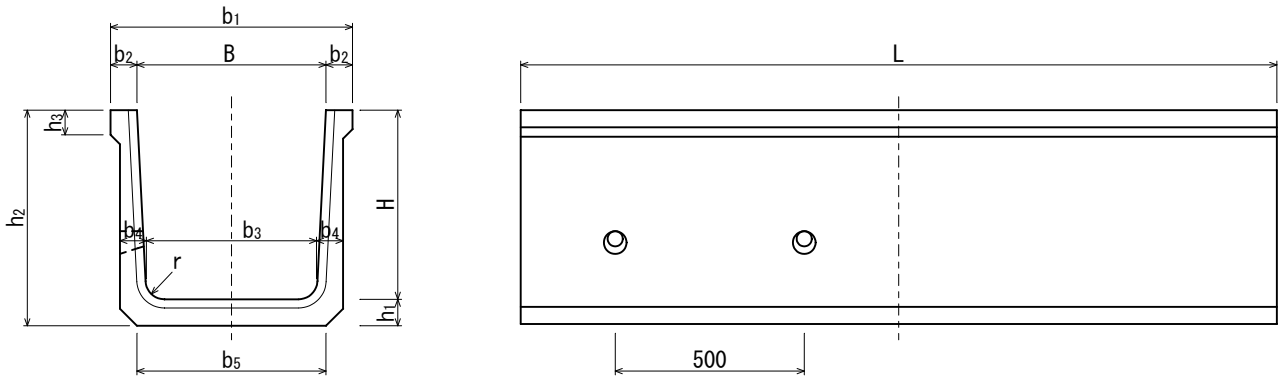

呼び名	寸法 (mm)												参考重量 (kg)	
	B	H	b <sub>1</sub>	b <sub>2</sub>	b <sub>3</sub>	b <sub>4</sub>	b <sub>5</sub>	h <sub>1</sub>	h <sub>2</sub>	h <sub>3</sub>	r	L	水路	排水路
303T	300	300	380	40	260	50	300	50	350	30	50	2000	205	203
404T	400	400	530	65	360	65	400	65	465	50	50	2000	354	352
505T	500	500	640	70	450	70	500	70	570	50	50	2000	463	461
606T	600	600	760	80	540	80	600	80	680	60	70	2000	650	647
806T	800	600	960	80	740	80	800	80	680	80	70	2000	783	780

U形水路用蓋

T-14  
T-6

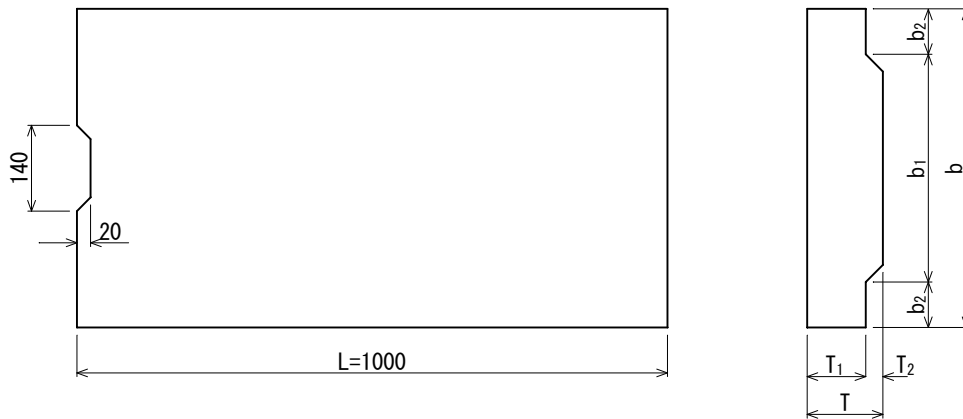

呼び名	T-14用蓋							T-6用蓋						
	寸法 (mm)						参考重量 (kg)	寸法 (mm)						参考重量 (kg)
	b	b <sub>1</sub>	b <sub>2</sub>	T	T <sub>1</sub>	T <sub>2</sub>		b	b <sub>1</sub>	b <sub>2</sub>	T	T <sub>1</sub>	T <sub>2</sub>	
30用蓋	—	—	—	—	—	—	—	430	290	70	70	60	10	69
40用蓋	—	—	—	—	—	—	—	550	390	80	75	65	10	95
45用蓋	—	—	—	—	—	—	—	600	440	80	75	65	10	104
50用蓋	670	490	90	120	100	20	184	670	490	90	80	70	10	124
60用蓋	780	590	95	120	100	20	216	780	590	95	85	75	10	155
70用蓋	850	690	80	130	110	20	258	850	690	80	90	80	10	180
80用蓋	950	790	80	130	110	20	289	950	790	80	90	80	10	201
90用蓋	1080	890	95	140	120	20	354	1080	890	95	95	85	10	242
100用蓋	1220	990	115	140	120	20	399	1220	990	115	95	85	10	273

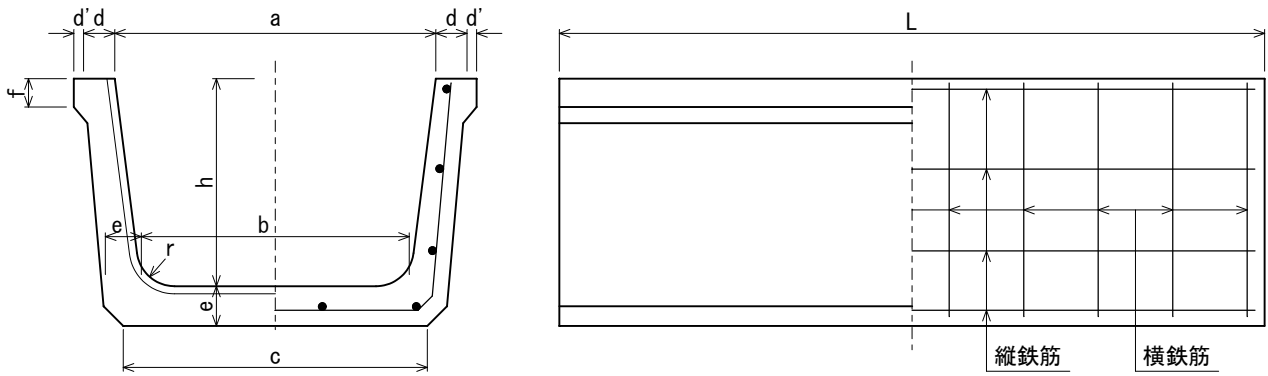

呼び名	寸法 (mm)										参考重量 (kg)
	a	b	c	d	d'	e	f	h	r	L	
200	200	170	205	30	10	35	25	150	30	2000	90
250	250	215	250	30	10	35	30	175	30	2000	106
300	300	260	300	30	10	40	30	200	40	2000	136
350	350	300	345	35	10	45	35	235	50	2000	180
400	400	345	395	40	15	50	40	260	50	2000	227
450	450	390	440	40	15	50	40	295	50	2000	253
500	500	435	490	45	15	55	45	320	60	2000	308
550	550	475	535	45	35	60	45	355	60	1000	187
600	600	520	580	45	35	60	50	380	60	1000	200
650	650	565	630	45	35	65	50	415	70	1000	230
700	700	610	680	50	40	70	50	440	70	1000	267
800	800	695	770	50	40	75	50	490	70	1000	312
900	900	785	870	55	40	85	60	550	80	1000	394
1000	1000	875	965	55	45	90	60	600	80	1000	452

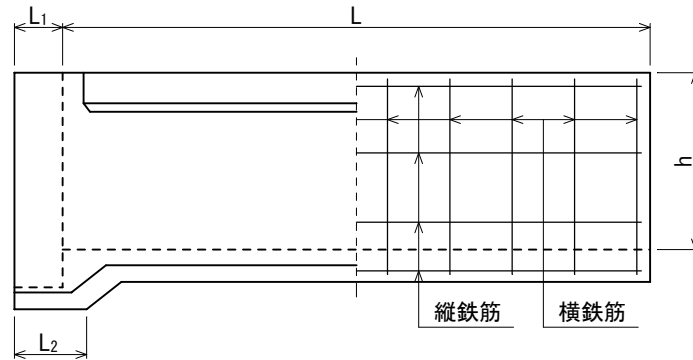

ソケット部

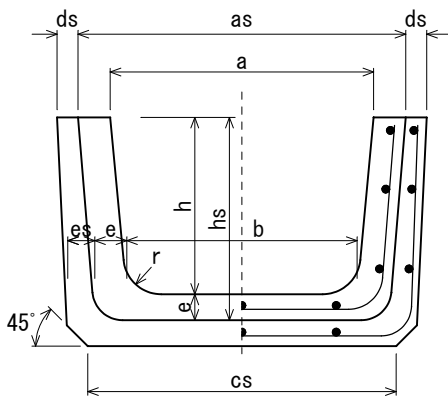

中央部

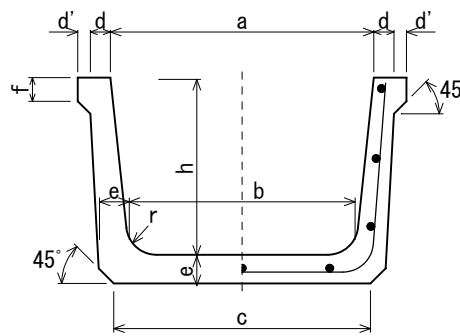

差口部

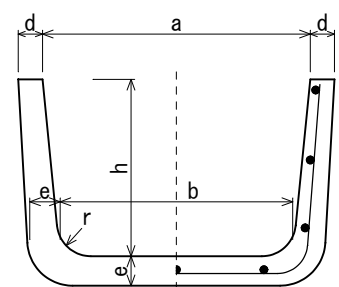

呼び名	寸法 (mm)																参考重量 (kg)
	a	b	c	d	d'	e	f	h	r	L	as	cs	es	ds	hs	L <sub>1</sub>	
200	200	170	205	30	10	35	25	150	30	2000	280	250	45	30	195	50	99
250	250	215	250	30	10	35	30	175	30	2000	330	330	45	30	220	50	112
300	300	260	300	30	10	40	30	200	40	2000	380	380	50	35	250	50	145
350	350	300	345	35	10	45	35	235	50	2000	440	435	55	40	290	50	191
400	400	345	395	40	15	50	40	260	50	2000	500	485	60	45	320	60	241
450	450	390	440	40	15	50	40	295	50	2000	550	530	60	45	355	60	269
500	500	435	490	45	15	55	45	320	60	2000	610	590	65	50	385	60	327
550	550	475	535	45	35	60	45	355	60	2000	660	645	70	55	425	70	385
600	600	520	580	45	35	60	50	380	60	2000	710	690	70	55	450	70	414
650	650	565	630	45	35	65	50	415	70	2000	760	740	75	60	490	70	479
700	700	610	680	50	40	70	50	440	70	2000	890	790	80	65	520	80	552
800	800	695	770	50	40	75	50	490	70	2000	920	890	85	70	575	80	646
900	900	785	870	55	40	85	60	550	80	2000	1030	1000	95	80	645	80	813
1000	1000	875	965	55	45	90	60	600	80	2000	1130	1085	100	85	700	80	939

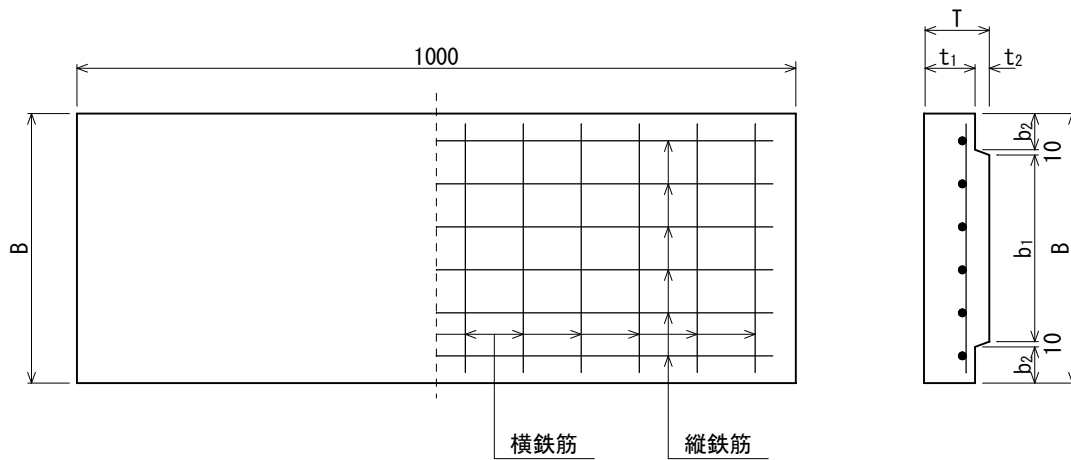

呼び名	寸法 (mm)						横鉄筋		縦鉄筋		参考重量 (kg)
	B	b <sub>1</sub>	b <sub>2</sub>	t <sub>1</sub>	t <sub>2</sub>	T	径	本数	径	本数	
200	280	174	43	50	10	60	D6	9	D6	3	38
250	330	224	43	50	10	60	D6	10	D6	3	45
300	380	274	43	60	10	70	D6	13	D6	4	61
350	440	324	48	60	10	70	D6	13	D6	4	71
400	510	374	58	60	10	70	D6	14	D6	4	82
450	560	424	58	70	10	80	D6	16	D6	4	104
500	620	474	63	70	10	80	D6	16	D6	5	114
550	710	524	83	70	10	80	D10	8	D6	5	132
600	760	574	83	80	10	90	D10	9	D6	6	159
650	810	624	83	80	10	90	D10	9	D6	6	170
700	880	674	93	80	10	90	D10	10	D6	7	185
800	980	774	93	90	10	100	D10	10	D6	7	230



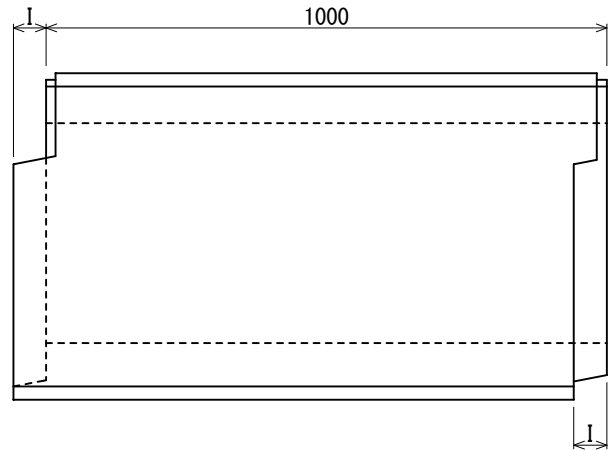
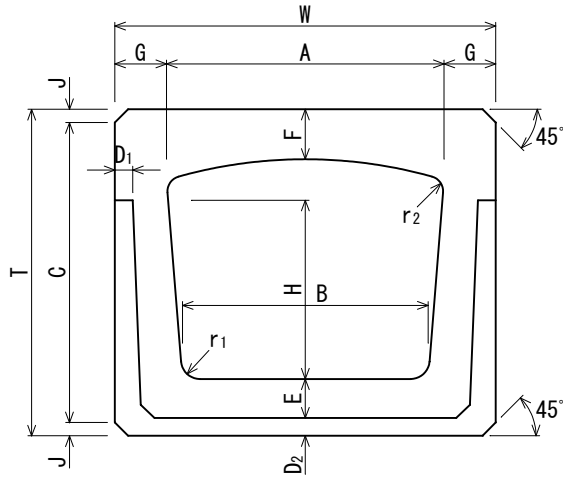

呼び名	寸 法 (mm)															参考重量 (kg)
	A	B	C	D <sub>1</sub>	D <sub>2</sub>	E	F	G	H	I	J	T	W	r <sub>1</sub>	r <sub>2</sub>	
250	250	215	315	22	22	48	60	65	175	50	15	375	380	30	20	209
300	300	260	380	22	22	53	65	65	200	50	15	410	430	40	20	248
350	350	300	415	22	22	58	70	70	235	50	20	455	490	50	20	304
400	400	345	440	27	22	63	75	80	260	60	25	490	560	50	20	370
450	450	390	475	27	22	63	75	80	295	60	25	525	610	50	20	409
500	500	435	520	32	32	68	90	90	320	60	30	580	680	60	20	518
550	550	475	565	32	32	73	95	90	355	60	30	625	730	60	20	582
600	600	520	590	32	32	73	95	90	380	60	30	650	780	60	20	623

# 遠心力鉄筋コンクリート管B形管

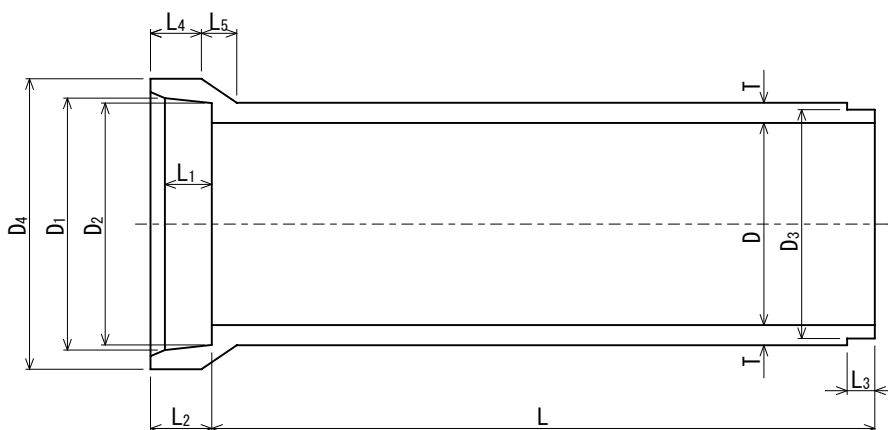

呼び名	寸 法 (mm)												参考重量 (kg)
	内径 D	D <sub>1</sub>	D <sub>2</sub>	D <sub>3</sub>	D <sub>4</sub>	厚さ T	L <sub>1</sub>	L <sub>2</sub>	L <sub>3</sub>	L <sub>4</sub>	L <sub>5</sub>	有効長 L	
150	150	210	206	194	262	26	65	90	32	115	50	2000	77
200	200	262	258	246	316	27	65	90	32	115	55	2000	103
250	250	314	310	298	370	28	65	90	32	120	60	2000	131
300	300	368	364	350	424	30	65	90	36	120	60	2000	165
350	350	422	418	404	482	32	65	90	36	120	65	2000	204
400	400	478	474	460	544	35	70	95	36	125	70	2430	306
450	450	534	530	516	606	38	70	95	36	125	75	2430	373
500	500	592	588	574	672	42	70	95	36	130	85	2430	459
600	600	708	704	690	804	50	75	100	36	135	100	2430	660
700	700	824	820	802	936	58	75	105	40	140	115	2430	899
800	800	940	936	918	1068	66	80	110	40	150	130	2430	1170
900	900	1058	1054	1036	1204	75	85	115	40	160	150	2430	1520
1000	1000	1172	1168	1150	1332	82	96	120	40	165	165	2430	1850
1100	1100	1286	1282	1260	1458	88	100	125	42	175	175	2430	2190
1200	1200	1400	1396	1374	1586	95	104	130	42	185	190	2430	2600
1350	1350	1566	1562	1540	1768	103	108	135	42	195	205	2430	3190

# 遠心力鉄筋コンクリート管C形管

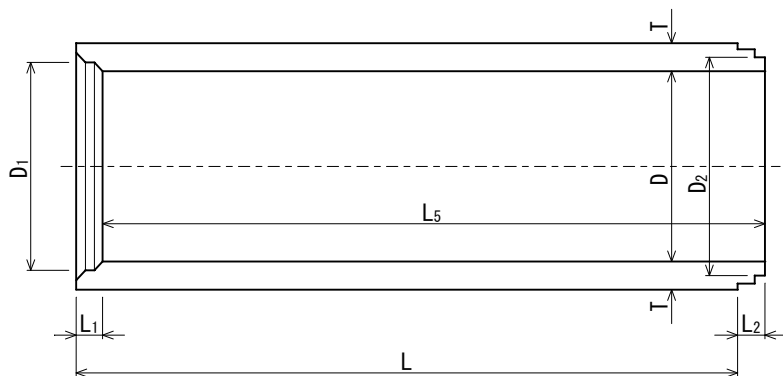

継手詳細部

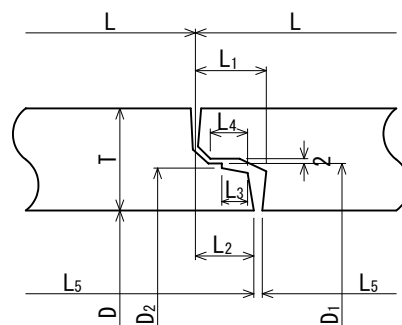

呼び名	寸 法 (mm)										参考重量 (kg)
	内径 D	D <sub>1</sub>	D <sub>2</sub>	厚さ T	L <sub>1</sub>	L <sub>2</sub>	L <sub>3</sub>	L <sub>4</sub>	有効長 L	L <sub>5</sub>	
1500	1500	1604	1588	112	62	52	27	49	2360	2352	3270
1650	1650	1760	1744	120	62	52	27	49	2360	2352	3850
1800	1800	1914	1898	127	62	52	27	49	2360	2352	4430
2000	2000	2132	2116	145	62	52	27	49	2360	2352	5640

# 鉄筋コンクリート人孔側塊

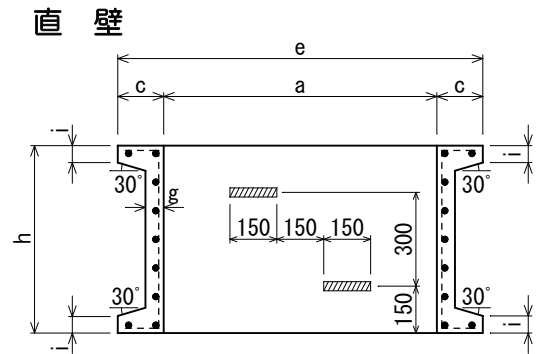
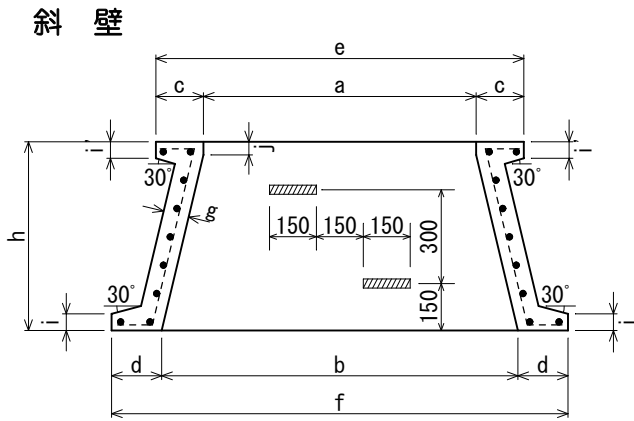

**片 斜 壁**

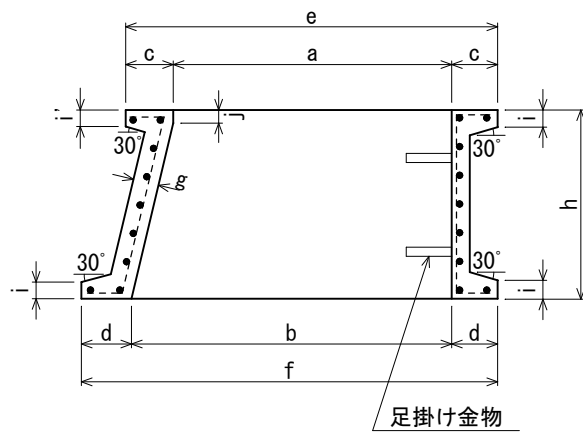

**人孔調整用ブロック**

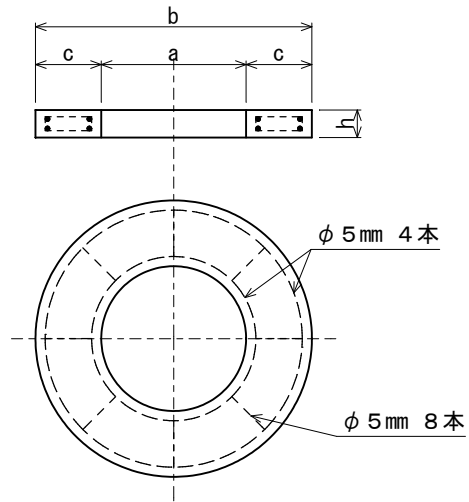

呼び名	寸 法 (mm)											らせん鉄筋		縦 鉄 筋		参考重量 (kg)		
	a	b	c	d	e	f	g	h	i	i'	j	径	本	径	本			
直 壁	900A	900	—	150	—	1200	—	60	300	50	50	—	5	6	5	20	240	
	900B	900	—	150	—	1200	—	60	600	50	50	—	5	9	5	20	370	
	1200A	1200	—	150	—	1500	—	70	300	50	50	—	5	6	5	28	350	
	1200B	1200	—	150	—	1500	—	70	600	50	50	—	5	9	5	28	500	
	1500A	1500	—	150	—	1800	—	80	300	50	50	—	5	6	5	36	400	
	1500B	1500	—	150	—	1800	—	80	600	50	50	—	5	9	5	36	685	
片 斜 壁	900用	300	600	900	250	150	1100	1200	60	300	50	60	30	6	7	6	20	340
		450	600	900	250	150	1100	1200	60	450	50	60	30	6	8	6	20	400
		600	600	900	250	150	1100	1200	60	600	50	60	30	6	10	6	20	445
1200用	600	1200	250	150	1100	1500	90	600	50	60	30	6	12	6	36	479		
斜 壁	600A	600	900	250	150	1100	1200	60	300	50	60	30	5	6	5	20	315	
	600B	600	900	250	150	1100	1200	60	450	50	60	30	5	7	5	20	360	
	600C	600	900	250	150	1100	1200	60	600	50	60	30	5	9	5	20	420	
	600D	600	1200	250	150	1100	1500	70	600	50	60	40	5	9	5	20	530	
	900	900	1200	150	150	1200	1500	70	600	50	50	—	5	9	5	28	465	
	1200	1200	1500	150	150	1500	1800	80	600	50	50	—	5	9	5	36	645	
調 整 ブ ロ ッ ク	600	50	600	1100	250	—	—	—	50	—	—	—	5	3	5	8	80	
		100	600	1100	250	—	—	—	100	—	—	—	5	4	5	8	159	
		150	600	1100	250	—	—	—	150	—	—	—	5	4	5	8	240	

# 人孔床版塊

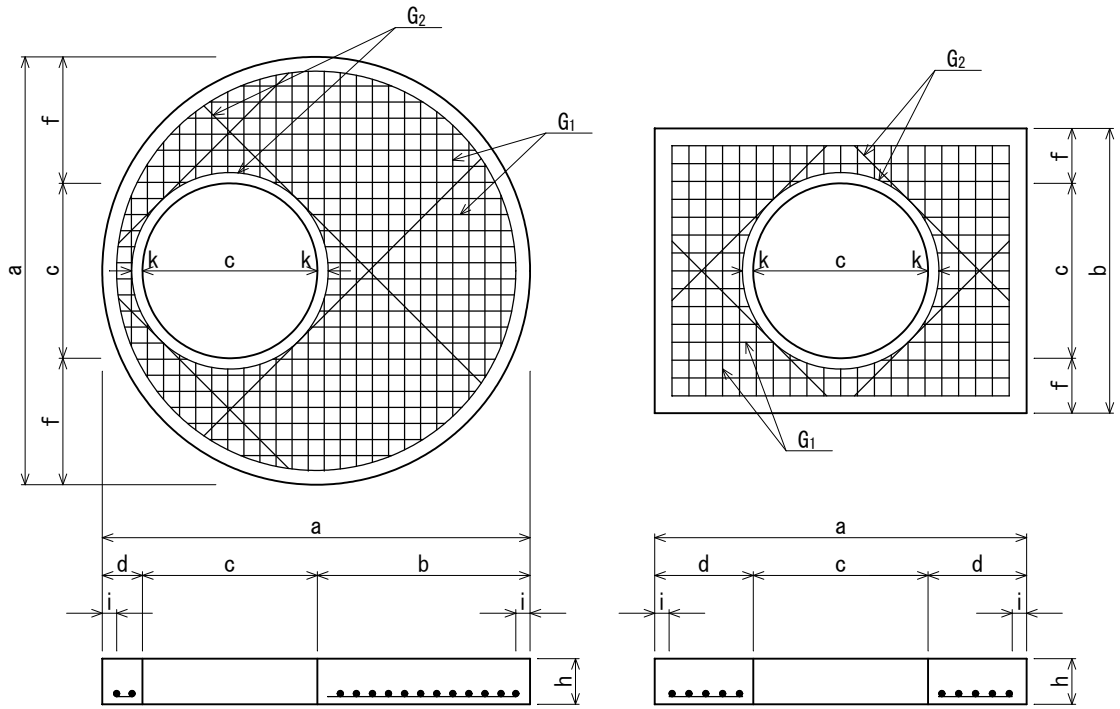

呼び名	寸法 (mm)								配筋			参考重量 (kg)
									G <sub>2</sub>		G <sub>1</sub>	
	a	b	c	d	f	i	k	h	径 (mm)	径 (mm)	ピッチ	
矩形用	1300	1000	600	150	300	60	40	150	D13	D10	60	367
1200	1500	750	600	150	450	60	40	200	D13	D10	60	558
1200丙	1700	850	600	250	550	60	60	200	D19	D16	100	993
1200丁	1700	550	900	250	400	60	60	200	D16	D13	100	785
1500丙	2000	850	900	250	550	60	60	200	D19	D16	80	1250
1500丁	2000	550	900	250	550	60	60	200	D16	D13	80	1250
1800	2400	1200	900	300	750	60	60	250	D19	D16	100	2430
2000	2600	1400	900	300	850	60	60	300	D19	D16	100	3370
2200	2800	1600	900	300	950	60	60	300	D19	D16	90	4150

# 鉄筋コンクリート汚水ます・排水ます（CD型）

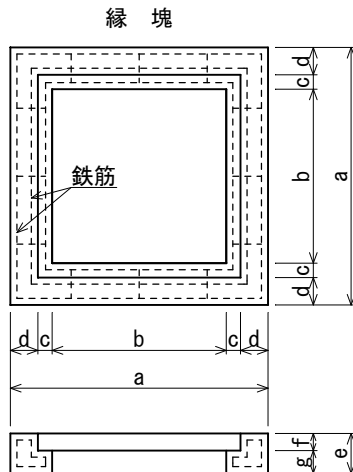
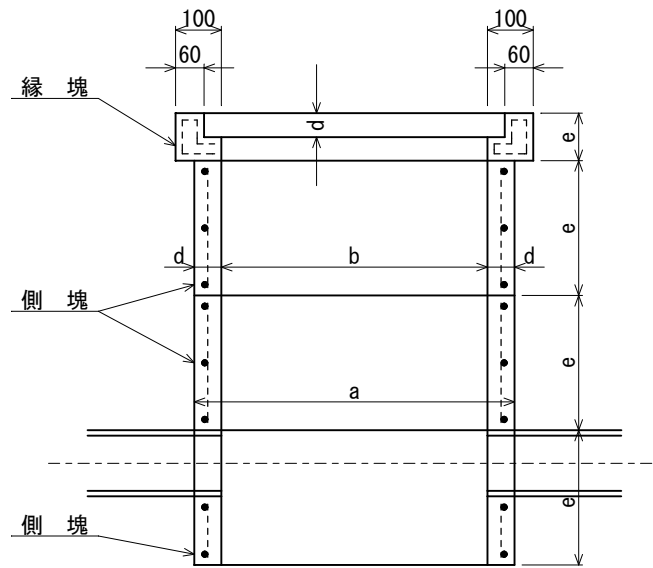

コンクリート蓋  
D型

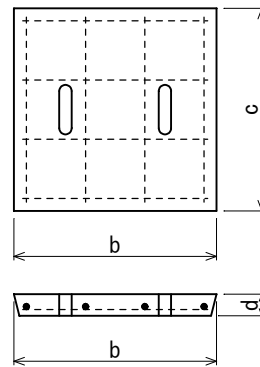

グレーチング蓋

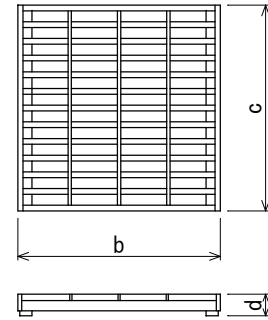

呼び名	寸法 (mm)									主鉄筋		配力筋		参考重量		T-2 グレーチ ング重量	
	a	b	c	d	e		f	g	径	本	径	本	(kg)				
コンクリートふた	300	—	370	370	50	—	—	—	4	4	4	4	17		9.2		
	360	—	430	430	50	—	—	—	4	4	4	4	23		12.0		
	450	—	520	520	50	—	—	—	6	4	6	4	33		16.7		
	500	—	570	570	50	—	—	—	6	4	6	4	38		29.3		
	600	—	670	670	60	—	—	—	6	4	6	4	63		32.5		
縁塊	300	500	300	40	60	100	53	47	3.2	5	3.2	4	32				
	360	560	360	40	60	100	53	47	4	5	4	8	36				
	450	650	450	40	60	100	53	47	4	5	4	8	42				
	500	700	500	40	60	100	53	47	4	5	4	8	47				
	600	800	600	40	60	100	63	37	6	5	4	12	55				
側塊	300	400	300	300	50	—	300	150	—	—	4	3	4	8	—	50	24
	360	460	360	360	50	—	300	150	—	—	4	3	4	12	—	58	29
	450	570	450	450	60	600	300	150	—	—	4	3	4	12	170	85	43
	500	620	500	500	60	600	300	150	—	—	4	3	4	12	188	94	47
	600	720	600	600	60	600	300	150	—	—	6	3	6	12	240	120	56

# 鉄筋コンクリート組立塀

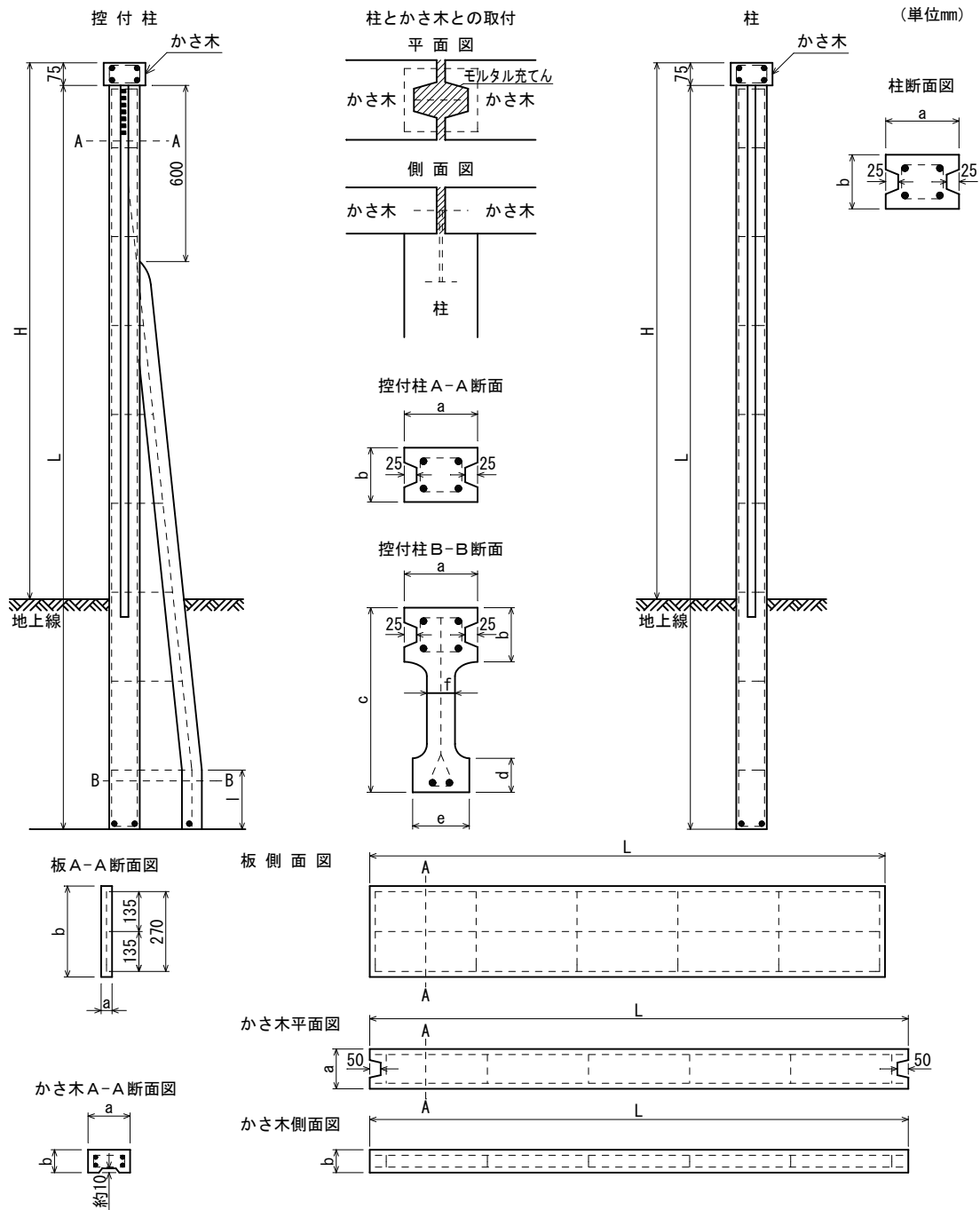

種類	高さ H (mm)	長さ			断面各部の寸法 (mm)								配筋				重量 (kg)
		L (mm)	l (mm)	許容差 (mm)	a	b	c	d	e	f	許容差	主筋		副筋			
												径 (mm)	本数 (本)	径 (mm)	本数 (本)		
控付柱	5番	1520	2050以上	0以上	—	120	106	290	45	90	45	+3 0	5	6	3.2	8	77
	6番	1820	2350以上	0以上	—	120	106	320	45	90	45	+3 0	6	6	3.2	9	96
	7番	2120	2650以上	300以上	—	120	106	320	45	90	45	+3 0	6	6	3.2	10	113
	8番	2420	2950以上	600以上	—	120	106	320	45	90	45	+3 0	柱部6 控部9	4 2	3.2	11	135
	9番	2720	3250以上	900以上	—	136	106	320	45	106	61	+3 0	9	6	3.2	13	160
	10番	3020	3550以上	1200以上	—	136	106	320	45	106	61	+3 0	9	6	3.2	14	190
柱	5番	1520	2050以上	—	—	120	106	—	—	—	—	+3 0	5	4	3.2	8	53
	6番	1820	2350以上	—	—	120	106	—	—	—	—	+3 0	6	4	3.2	9	60
	7番	2120	2650以上	—	—	120	106	—	—	—	—	+3 0	6	4	3.2	10	67
	8番	2420	2950以上	—	—	120	106	—	—	—	—	+3 0	6	4	3.2	11	75
	9番	2720	3250以上	—	—	136	106	—	—	—	—	+3 0	10	4	3.2	13	96
	10番	3020	3550以上	—	—	136	106	—	—	—	—	+3 0	10	4	3.2	14	104
板	—	1720	—	±2	30	297	—	—	—	—	—	aは+3 -1 bは+3 0	3.2	3	3.2	6	36
かさ木	—	1800	—		136	75	—	—	—	—	—	+3 0	3.2	4	3.2	6	42

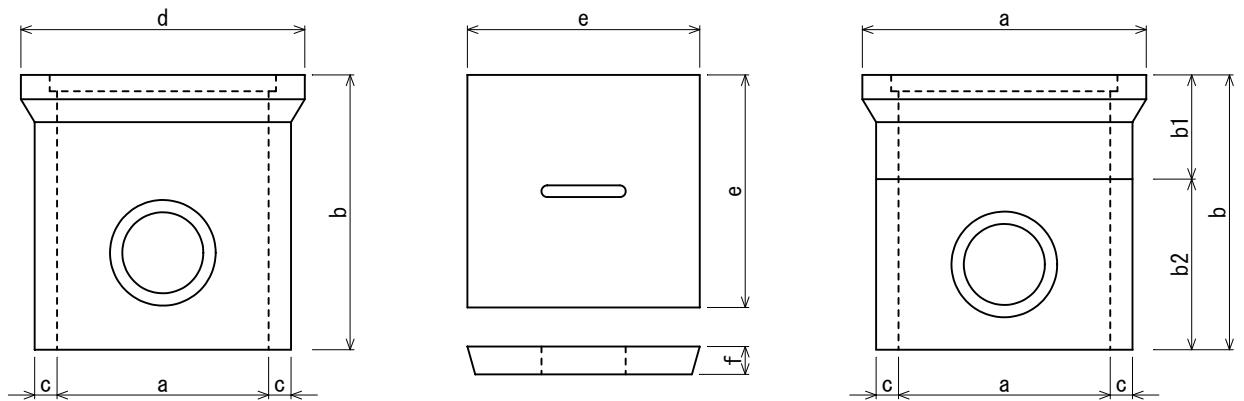

呼び名	寸 法 (mm)								参考重量 (kg)
	a	b	b1	b2	c	d	e	f	
240型	240	380	—	—	30	325	255	35	27
240ｼﾝｸﾞ型	240	600	—	—	30	325	255	35	41
300型	300	450	—	—	30	385	315	35	39
300ｼﾝｸﾞ型	300	600	—	—	30	385	315	35	56
360型	360	500	—	—	30	450	375	35	56
450A型	450	500	—	—	30	550	465	40	82
450B型	450	600	—	—	30	550	465	40	98
600型	600	750	250	500	45	720	620	50	184

## 改良栴

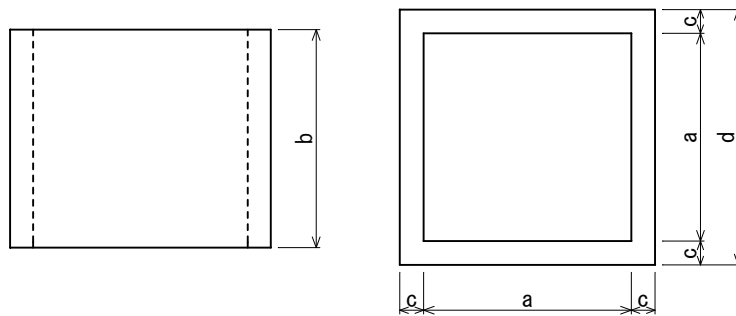

呼び名	寸 法 (mm)				参考重量 (kg)	呼び名	寸 法 (mm)				参考重量 (kg)
	a	b	c	d			a	b	c	d	
240×150	240	150	30	300	11	450×150	450	150	40	530	24
240×200	240	200	30	300	14	450×200	450	200	40	530	33
240×300	240	300	30	300	22	450×300	450	300	40	530	49
300×150	300	150	30	360	17	600×150	600	150	45	690	37
300×200	300	200	30	360	23	600×200	600	200	45	690	49
300×300	300	300	30	360	34	600×300	600	300	45	690	74
360×150	360	150	35	430	18	600×500	600	500	45	690	123
360×200	360	200	35	430	24						
360×300	360	300	35	430	35						



井戸側

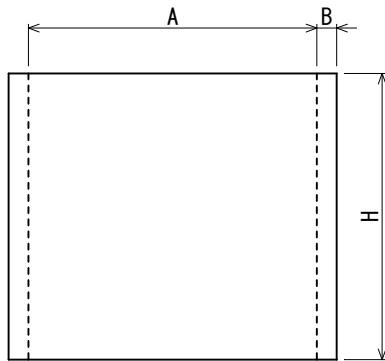
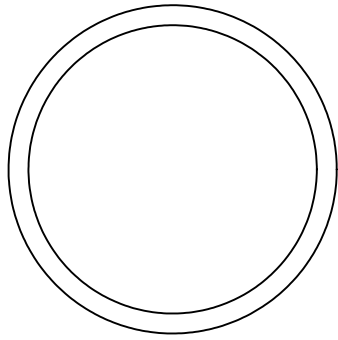

井戸側 (穴明き)

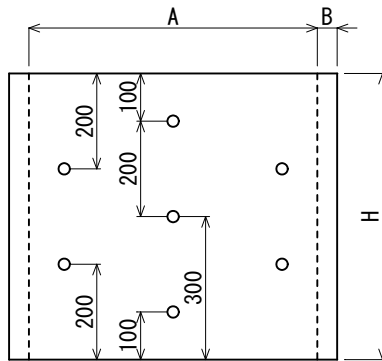
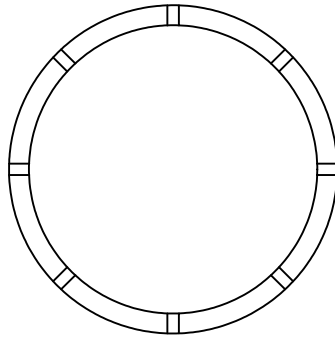

井戸側蓋

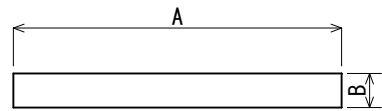
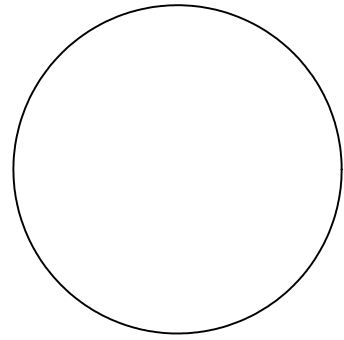

井戸側

呼び名	寸法 (mm)			参考重量 (kg)
	A	B	H	
600	600	40	600	115
750	750	50	600	180
900	900	60	600	260
1000	1000	60	600	288
1200A	1200	80	600	460
1200B	1200	80	1000	760
1500	1500	90	600	650

井戸側蓋

呼び名	寸法 (mm)		参考重量 (kg)
	A	B	
600	720	65	63
750	885	70	100
900	1060	80	170
1000	1160	80	200
1200	1430	90	347
1500	1750	100	577



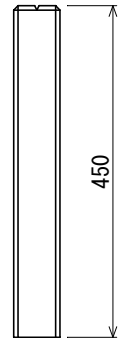
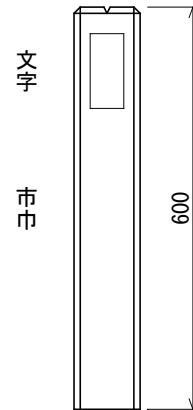
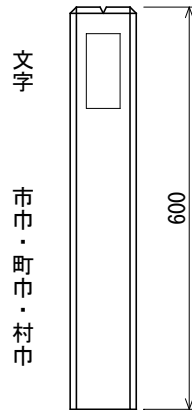
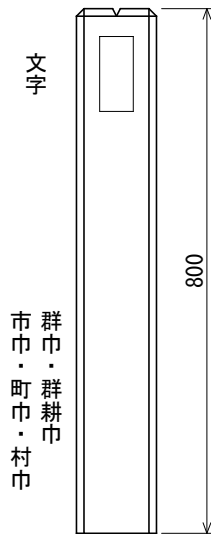
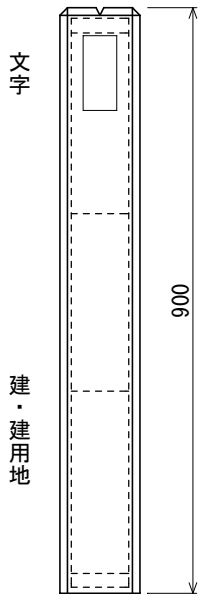
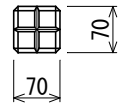
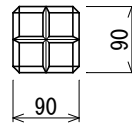
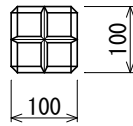
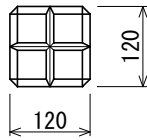
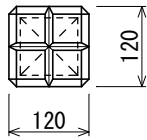

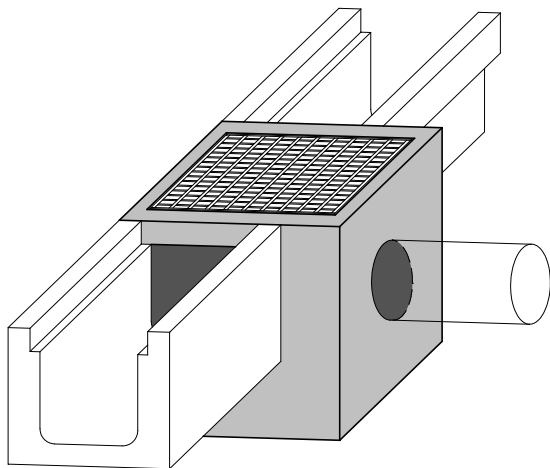

- \* グレーチングなしも同一寸法で製造いたします。
- \* 製造可能なますの高さ（H）には、原則制限はありません。
- \* グレーチングは、ボルト固定式、トライポット式等を含む全てのタイプが使用可能です。
- \* A、B寸法の異なる異形枳も製造いたします。
- \* 接続するU字溝・ヒューム管に合わせ開口いたします。

## 底版なし

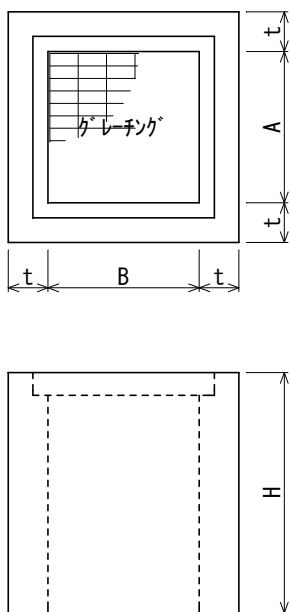

## サイズ別標準製造寸法

ます穴 (A x B)	壁 厚 (mm)			
	120	150	200	250
300x300	○	○		
400x400	○	○		
450x450	○	○		
500x500		○		
600x600		○	○	
700x700		○	○	
800x800		○	○	
900x900		○	○	
1000x1000		○	○	○
1100x1100		○	○	○
1200x1200		○	○	○
1300x1300			○	○
1400x1400			○	○
1500x1500			○	○
1600x1600			○	○
1700x1700			○	○
1800x1800			○	○
1900x1900			○	○
2000x2000			○	○



異形桧

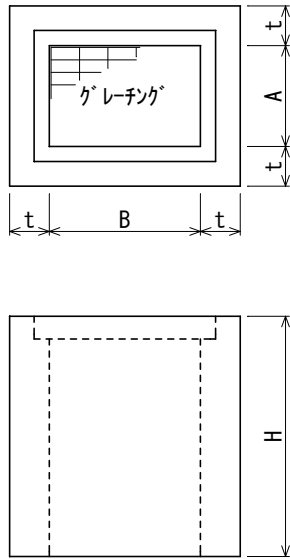

異形サイズ別標準製造寸法

ます穴 (A x B)	壁厚 (mm)		
	150	200	250
600x 700~1200	○	○	
700x 800~1200	○	○	
800x 900~1200	○	○	
900x1000~1200	○	○	
1000x1100~1200	○	○	○
1100x1200	○	○	○
1000x1300~2000		○	○
1100x1300~2000		○	○
1200x1300~2000		○	○
1300x1400~2000		○	○
1400x1500~2000		○	○
1500x1600~2000		○	○
1600x1700~2000		○	○
1700x1800~2000		○	○
1800x1900~2000		○	○
1900x2000		○	○

グレーチング  
普通目

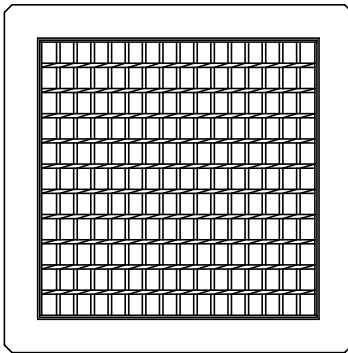

グレーチング  
細目

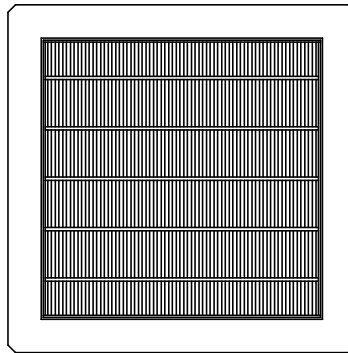

コンクリート蓋

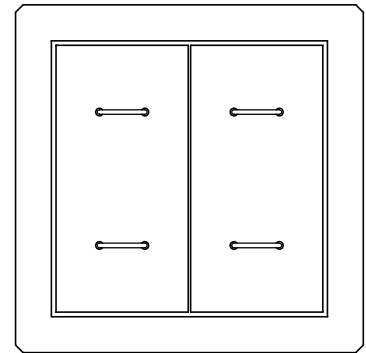

グレーチング  
ボルト固定

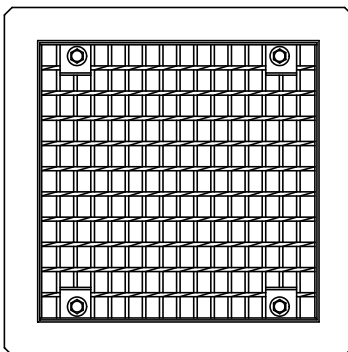

グレーチング  
細目ボルト固定

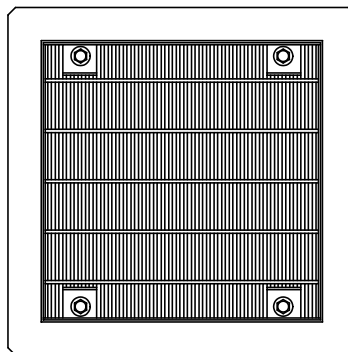

分水桧

